

# TCRP

## REPORT 90

TRANSIT  
COOPERATIVE  
RESEARCH  
PROGRAM

### Bus Rapid Transit

#### *Volume 2: Implementation Guidelines*



TRANSPORTATION RESEARCH BOARD  
OF THE NATIONAL ACADEMIES

Sponsored by  
the Federal  
Transit Administration

**TCRP OVERSIGHT AND PROJECT  
SELECTION COMMITTEE**  
(as of June 2003)

**CHAIR**

J. BARRY BARKER  
*Transit Authority of River City*

**MEMBERS**

DANNY ALVAREZ  
*Miami-Dade Transit Agency*  
KAREN ANTION  
*Karen Antion Consulting*  
GORDON AOYAGI  
*Montgomery County Government*  
JEAN PAUL BAILLY  
*Union Internationale des Transports Publics*  
RONALD L. BARNES  
*Central Ohio Transit Authority*  
LINDA J. BOHLINGER  
*HNTB Corp.*  
ANDREW BONDS, JR.  
*Parsons Transportation Group, Inc.*  
JENNIFER L. DORN  
*FTA*  
NATHANIEL P. FORD, SR.  
*Metropolitan Atlanta RTA*  
CONSTANCE GARBER  
*York County Community Action Corp.*  
FRED M. GILLIAM  
*Capital Metropolitan Transportation Authority*  
KIM R. GREEN  
*GFI GENFARE*  
SHARON GREENE  
*Sharon Greene & Associates*  
JILL A. HOUGH  
*North Dakota State University*  
ROBERT H. IRWIN  
*British Columbia Transit*  
CELIA G. KUPERSMITH  
*Golden Gate Bridge, Highway and  
Transportation District*  
PAUL J. LARROUSSE  
*National Transit Institute*  
DAVID A. LEE  
*Connecticut Transit*  
CLARENCE W. MARSELLA  
*Denver Regional Transportation District*  
FAYE L. M. MOORE  
*Southeastern Pennsylvania  
Transportation Authority*  
STEPHANIE L. PINSON  
*Gilbert Tweed Associates, Inc.*  
ROBERT H. PRINCE, JR.  
*DMJM+HARRIS*  
JEFFREY M. ROSENBERG  
*Amalgamated Transit Union*  
RICHARD J. SIMONETTA  
*pbConsult*  
PAUL P. SKOUTELAS  
*Port Authority of Allegheny County*  
LINDA S. WATSON  
*Corpus Christi RTA*

**EX OFFICIO MEMBERS**

WILLIAM W. MILLAR  
*APTA*  
MARY E. PETERS  
*FHWA*  
JOHN C. HORSLEY  
*AASHTO*  
ROBERT E. SKINNER, JR.  
*TRB*

**TDC EXECUTIVE DIRECTOR**

LOUIS F. SANDERS  
*APTA*

**SECRETARY**

ROBERT J. REILLY  
*TRB*

**TRANSPORTATION RESEARCH BOARD EXECUTIVE COMMITTEE 2003 (Membership as of August 2003)**

**OFFICERS**

**Chair:** Genevieve Giuliano, Director and Prof., School of Policy, Planning, and Development, USC, Los Angeles  
**Vice Chair:** Michael S. Townes, President and CEO, Hampton Roads Transit, Hampton, VA  
**Executive Director:** Robert E. Skinner, Jr., Transportation Research Board

**MEMBERS**

MICHAEL W. BEHRENS, Executive Director, Texas DOT  
JOSEPH H. BOARDMAN, Commissioner, New York State DOT  
SARAH C. CAMPBELL, President, TransManagement, Inc., Washington, DC  
E. DEAN CARLSON, President, Carlson Associates, Topeka, KS  
JOANNE F. CASEY, President and CEO, Intermodal Association of North America  
JAMES C. CODELL III, Secretary, Kentucky Transportation Cabinet  
JOHN L. CRAIG, Director, Nebraska Department of Roads  
BERNARD S. GROSECLOSE, JR., President and CEO, South Carolina State Ports Authority  
SUSAN HANSON, Landry University Prof. of Geography, Graduate School of Geography, Clark University  
LESTER A. HOEL, L. A. Lacy Distinguished Professor, Depart. of Civil Engineering, University of Virginia  
HENRY L. HUNGERBEELER, Director, Missouri DOT  
ADIB K. KANAFANI, Cahill Prof. and Chair, Dept. of Civil and Environmental Engineering, University of California at Berkeley  
RONALD F. KIRBY, Director of Transportation Planning, Metropolitan Washington Council of Governments  
HERBERT S. LEVINSON, Principal, Herbert S. Levinson Transportation Consultant, New Haven, CT  
MICHAEL D. MEYER, Professor, School of Civil and Environmental Engineering, Georgia Institute of Technology  
JEFF P. MORALES, Director of Transportation, California DOT  
KAM MOVASSAGHI, Secretary of Transportation, Louisiana Department of Transportation and Development  
CAROL A. MURRAY, Commissioner, New Hampshire DOT  
DAVID PLAVIN, President, Airports Council International, Washington, DC  
JOHN REBENDSOLF, Vice Pres., Network and Service Planning, Union Pacific Railroad Co., Omaha, NE  
CATHERINE L. ROSS, Harry West Chair of Quality Growth and Regional Development, College of Architecture, Georgia Institute of Technology  
JOHN M. SAMUELS, Sr. Vice Pres., Operations, Planning and Support, Norfolk Southern Corporation, Norfolk, VA  
PAUL P. SKOUTELAS, CEO, Port Authority of Allegheny County, Pittsburgh, PA  
MARTIN WACHS, Director, Institute of Transportation Studies, University of California at Berkeley  
MICHAEL W. WICKHAM, Chairman and CEO, Roadway Express, Inc., Akron, OH

**EX OFFICIO MEMBERS**

MARION C. BLAKEY, Federal Aviation Administrator, U.S.DOT  
SAMUEL G. BONASSO, Acting Administrator, Research and Special Programs Administration, U.S.DOT (ex officio)  
REBECCA M. BREWSTER, President and COO, American Transportation Research Institute, Smyrna, GA  
THOMAS H. COLLINS (Adm., U.S. Coast Guard), Commandant, U.S. Coast Guard  
JENNIFER L. DORN, Federal Transit Administrator, U.S.DOT  
ROBERT B. FLOWERS (Lt. Gen., U.S. Army), Chief of Engineers and Commander, U.S. Army Corps of Engineers  
HAROLD K. FORSEN, Foreign Secretary, National Academy of Engineering  
EDWARD R. HAMBERGER, President and CEO, Association of American Railroads  
JOHN C. HORSLEY, Exec. Dir., American Association of State Highway and Transportation Officials  
MICHAEL P. JACKSON, Deputy Secretary of Transportation, U.S.DOT  
ROGER L. KING, Chief Applications Technologist, National Aeronautics and Space Administration  
ROBERT S. KIRK, Director, Office of Advanced Automotive Technologies, U.S. DOE  
RICK KOWALEWSKI, Acting Director, Bureau of Transportation Statistics, U.S.DOT  
WILLIAM W. MILLAR, President, American Public Transportation Association  
MARY E. PETERS, Federal Highway Administrator, U.S.DOT  
SUZANNE RUDZINSKI, Director, Transportation and Regional Programs, U.S. EPA  
JEFFREY W. RUNGE, National Highway Traffic Safety Administrator, U.S.DOT  
ALLAN RUTTER, Federal Railroad Administrator, U.S.DOT  
ANNETTE M. SANDBERG, Deputy Administrator, Federal Motor Carrier Safety Administration, U.S.DOT  
WILLIAM G. SCHUBERT, Maritime Administrator, U.S.DOT

**TRANSIT COOPERATIVE RESEARCH PROGRAM**

*Transportation Research Board Executive Committee Subcommittee for TCRP*

GENEVIEVE GIULIANO, University of Southern California, Los Angeles (Chair)  
E. DEAN CARLSON, Carlson Associates, Topeka, KS  
JENNIFER L. DORN, Federal Transit Administration, U.S.DOT  
LESTER A. HOEL, University of Virginia  
WILLIAM W. MILLAR, American Public Transportation Association  
ROBERT E. SKINNER, JR., Transportation Research Board  
PAUL P. SKOUTELAS, Port Authority of Allegheny County, Pittsburgh, PA  
MICHAEL S. TOWNES, Hampton Roads Transit, Hampton, VA

---

---

**TCRP REPORT 90**

---

---

**Bus Rapid Transit**

***Volume 2: Implementation  
Guidelines***

**HERBERT S. LEVINSON**  
New Haven, CT

**SAMUEL ZIMMERMAN**  
**JENNIFER CLINGER**

**JAMES GAST**  
DMJM+HARRIS  
Fairfax, VA

**SCOTT RUTHERFORD**  
University of Washington  
Seattle, WA

and

**ERIC BRUHN**  
Transit Resource Center  
Philadelphia, PA

**SUBJECT AREAS**  
Public Transit

---

Research Sponsored by the Federal Transit Administration in Cooperation with the Transit Development Corporation

---

**TRANSPORTATION RESEARCH BOARD**

WASHINGTON, D.C.  
2003  
[www.TRB.org](http://www.TRB.org)

## TRANSIT COOPERATIVE RESEARCH PROGRAM

The nation's growth and the need to meet mobility, environmental, and energy objectives place demands on public transit systems. Current systems, some of which are old and in need of upgrading, must expand service area, increase service frequency, and improve efficiency to serve these demands. Research is necessary to solve operating problems, to adapt appropriate new technologies from other industries, and to introduce innovations into the transit industry. The Transit Cooperative Research Program (TCRP) serves as one of the principal means by which the transit industry can develop innovative near-term solutions to meet demands placed on it.

The need for TCRP was originally identified in *TRB Special Report 213—Research for Public Transit: New Directions*, published in 1987 and based on a study sponsored by the Urban Mass Transportation Administration—now the Federal Transit Administration (FTA). A report by the American Public Transportation Association (APTA), *Transportation 2000*, also recognized the need for local, problem-solving research. TCRP, modeled after the longstanding and successful National Cooperative Highway Research Program, undertakes research and other technical activities in response to the needs of transit service providers. The scope of TCRP includes a variety of transit research fields including planning, service configuration, equipment, facilities, operations, human resources, maintenance, policy, and administrative practices.

TCRP was established under FTA sponsorship in July 1992. Proposed by the U.S. Department of Transportation, TCRP was authorized as part of the Intermodal Surface Transportation Efficiency Act of 1991 (ISTEA). On May 13, 1992, a memorandum agreement outlining TCRP operating procedures was executed by the three cooperating organizations: FTA, The National Academies, acting through the Transportation Research Board (TRB); and the Transit Development Corporation, Inc. (TDC), a nonprofit educational and research organization established by APTA. TDC is responsible for forming the independent governing board, designated as the TCRP Oversight and Project Selection (TOPS) Committee.

Research problem statements for TCRP are solicited periodically but may be submitted to TRB by anyone at any time. It is the responsibility of the TOPS Committee to formulate the research program by identifying the highest priority projects. As part of the evaluation, the TOPS Committee defines funding levels and expected products.

Once selected, each project is assigned to an expert panel, appointed by the Transportation Research Board. The panels prepare project statements (requests for proposals), select contractors, and provide technical guidance and counsel throughout the life of the project. The process for developing research problem statements and selecting research agencies has been used by TRB in managing cooperative research programs since 1962. As in other TRB activities, TCRP project panels serve voluntarily without compensation.

Because research cannot have the desired impact if products fail to reach the intended audience, special emphasis is placed on disseminating TCRP results to the intended end users of the research: transit agencies, service providers, and suppliers. TRB provides a series of research reports, syntheses of transit practice, and other supporting material developed by TCRP research. APTA will arrange for workshops, training aids, field visits, and other activities to ensure that results are implemented by urban and rural transit industry practitioners.

The TCRP provides a forum where transit agencies can cooperatively address common operational problems. The TCRP results support and complement other ongoing transit research and training programs.

## TCRP REPORT 90: Volume 2

Project A-23 FY'99  
ISSN 1073-4872  
ISBN 0-309-08751-1  
Library of Congress Control Number 2003105419

© 2003 Transportation Research Board

**Price (Volume 2) \$27.00**

### NOTICE

The project that is the subject of this report was a part of the Transit Cooperative Research Program conducted by the Transportation Research Board with the approval of the Governing Board of the National Research Council. Such approval reflects the Governing Board's judgment that the project concerned is appropriate with respect to both the purposes and resources of the National Research Council.

The members of the technical advisory panel selected to monitor this project and to review this report were chosen for recognized scholarly competence and with due consideration for the balance of disciplines appropriate to the project. The opinions and conclusions expressed or implied are those of the research agency that performed the research, and while they have been accepted as appropriate by the technical panel, they are not necessarily those of the Transportation Research Board, the National Research Council, the Transit Development Corporation, or the Federal Transit Administration of the U.S. Department of Transportation.

Each report is reviewed and accepted for publication by the technical panel according to procedures established and monitored by the Transportation Research Board Executive Committee and the Governing Board of the National Research Council.

### Special Notice

The Transportation Research Board of The National Academies, the National Research Council, the Transit Development Corporation, and the Federal Transit Administration (sponsor of the Transit Cooperative Research Program) do not endorse products or manufacturers. Trade or manufacturers' names appear herein solely because they are considered essential to the clarity and completeness of the project reporting.

*Published reports of the*

## TRANSIT COOPERATIVE RESEARCH PROGRAM

*are available from:*

Transportation Research Board  
Business Office  
500 Fifth Street, NW  
Washington, DC 20001

and can be ordered through the Internet at  
<http://www.national-academies.org/trb/bookstore>

Printed in the United States of America

# THE NATIONAL ACADEMIES

## *Advisers to the Nation on Science, Engineering, and Medicine*

The **National Academy of Sciences** is a private, nonprofit, self-perpetuating society of distinguished scholars engaged in scientific and engineering research, dedicated to the furtherance of science and technology and to their use for the general welfare. On the authority of the charter granted to it by the Congress in 1863, the Academy has a mandate that requires it to advise the federal government on scientific and technical matters. Dr. Bruce M. Alberts is president of the National Academy of Sciences.

The **National Academy of Engineering** was established in 1964, under the charter of the National Academy of Sciences, as a parallel organization of outstanding engineers. It is autonomous in its administration and in the selection of its members, sharing with the National Academy of Sciences the responsibility for advising the federal government. The National Academy of Engineering also sponsors engineering programs aimed at meeting national needs, encourages education and research, and recognizes the superior achievements of engineers. Dr. William A. Wulf is president of the National Academy of Engineering.

The **Institute of Medicine** was established in 1970 by the National Academy of Sciences to secure the services of eminent members of appropriate professions in the examination of policy matters pertaining to the health of the public. The Institute acts under the responsibility given to the National Academy of Sciences by its congressional charter to be an adviser to the federal government and, on its own initiative, to identify issues of medical care, research, and education. Dr. Harvey V. Fineberg is president of the Institute of Medicine.

The **National Research Council** was organized by the National Academy of Sciences in 1916 to associate the broad community of science and technology with the Academy's purposes of furthering knowledge and advising the federal government. Functioning in accordance with general policies determined by the Academy, the Council has become the principal operating agency of both the National Academy of Sciences and the National Academy of Engineering in providing services to the government, the public, and the scientific and engineering communities. The Council is administered jointly by both the Academies and the Institute of Medicine. Dr. Bruce M. Alberts and Dr. William A. Wulf are chair and vice chair, respectively, of the National Research Council.

The **Transportation Research Board** is a division of the National Research Council, which serves the National Academy of Sciences and the National Academy of Engineering. The Board's mission is to promote innovation and progress in transportation through research. In an objective and interdisciplinary setting, the Board facilitates the sharing of information on transportation practice and policy by researchers and practitioners; stimulates research and offers research management services that promote technical excellence; provides expert advice on transportation policy and programs; and disseminates research results broadly and encourages their implementation. The Board's varied activities annually engage more than 4,000 engineers, scientists, and other transportation researchers and practitioners from the public and private sectors and academia, all of whom contribute their expertise in the public interest. The program is supported by state transportation departments, federal agencies including the component administrations of the U.S. Department of Transportation, and other organizations and individuals interested in the development of transportation. [www.TRB.org](http://www.TRB.org)

[www.national-academies.org](http://www.national-academies.org)

## COOPERATIVE RESEARCH PROGRAMS STAFF FOR TCRP REPORT 90, VOLUME 2

ROBERT J. REILLY, *Director, Cooperative Research Programs*  
CHRISTOPHER W. JENKS, *TCRP Manager*  
GWEN CHISHOLM, *Senior Program Officer*  
EILEEN P. DELANEY, *Managing Editor*  
ELLEN M. CHAFEE, *Assistant Editor*  
BETH HATCH, *Assistant Editor*

### PROJECT PANEL A-23

#### Field of Operations

JACK M. REILLY, *Capital District Transportation Authority, Albany, NY (Chair)*  
LEO J. BEVON, *Department of Rail and Public Transportation, Richmond, VA*  
GRAHAM CAREY, *Lane Transit District, Eugene, OR*  
ROSEMARY COVINGTON, *Parsons Brinckerhoff Quade & Douglas, Cleveland, OH*  
JOHN DOCKENDORF, *Pennsylvania DOT*  
DAVID R. FIALKOFF, *Miami-Dade Transit Agency*  
LEON GOODMAN, *Parsons Transportation Group, New York, NY*  
JAMES R. LIGHTBODY, *Santa Clara Valley Transportation Authority, San Jose, CA*  
MICHAEL H. MULHERN, *Massachusetts Bay Transportation Authority*  
JOHN M. MUTH, *Charlotte Area Transit System*  
MICHAEL SANDERS, *Connecticut DOT*  
PAUL STEFFENS, *Honolulu Department of Transportation Services*  
JUAN F. SUAREZ LEMUS, *Metropolitan Bus Authority, Rio Piedras, PR*  
STAN TEPLY, *University of Alberta, Edmonton, AB, Canada*  
GARET WALSH, *Charlotte-Mecklenburg Planning Commission*  
MARTHA WELBORNE, *Surface Transit Project, Los Angeles, CA*  
BERT ARRILLAGA, *FTA Liaison Representative*  
JOEL WASHINGTON, *FTA Liaison Representative*  
PETER SHAW, *TRB Liaison Representative*

# FOREWORD

By *Gwen Chisholm*  
*Staff Officer*  
*Transportation Research*  
*Board*

*TCRP Report 90: Bus Rapid Transit*, which is published as a two-volume set, identifies the potential range of bus rapid transit (BRT) applications through 26 case studies and provides planning and implementation guidelines for BRT. This report will be useful to policy-makers, chief executive officers, senior managers, and planners.

---

Increasing levels of urban congestion create the need for new transportation solutions. A creative, emerging public transit solution is BRT. While a precise definition of BRT is elusive, it is generally understood to include bus services that are, at a minimum, faster than traditional “local bus” service and that may include dedicated bus infrastructure improvements such as grade-separated bus operations. The essential features of BRT systems are frequent, all-day service; some form of bus priority; attractive, substantive stations and terminals; quiet, low-emission vehicles configured for the respective markets and services; fare collection mechanisms that permit faster passenger boarding; and a system image that is uniquely identifiable. BRT represents a way to improve mobility at a relatively low cost through incremental investment in a combination of bus infrastructure, equipment, operational improvements, and technology.

Despite the potential cost and mobility benefits, however, the transportation profession lacks a consolidated and generally accepted set of principles for planning, designing, and operating BRT vehicles and facilities. Transit agencies need guidance on how to successfully implement BRT in the political, institutional, and operational context of the United States. *Volume 1: Case Studies in Bus Rapid Transit* provides information on the potential range of BRT applications, covering planning and implementation background and system description, including operations and physical elements. *Volume 2: Implementation Guidelines* covers the main components of BRT and describes BRT concepts, planning considerations, key issues, the system development process, desirable conditions for BRT, and general planning principles. It also provides an overview of system types and elements, including stations, vehicles, services, fare collection, running ways, and ITS applications.

This report was prepared by Herbert Levinson of New Haven, Connecticut; Samuel Zimmerman, Jennifer Clinger, and James Gast of DMJM+HARRIS in Fairfax, Virginia; Scott Rutherford of Seattle, Washington; and Eric Bruhn of Philadelphia, Pennsylvania.

Both volumes issued under *TCRP Report 90* can be found on the TRB website at [nationalacademies.org/trb](http://nationalacademies.org/trb).

# CONTENTS

- S-1 SUMMARY**
  - S-1. What is BRT?, S-1
  - S-2. Planning, S-1
  - S-3. Running Ways, S-2
  - S-4. Traffic Engineering, S-9
  - S-5. Stops, Stations, and Terminals, S-9
  - S-6. Vehicles, S-10
  - S-7. Intelligent Transportation Systems, S-11
  - S-8. Service, Fares, and Marketing, S-12
  - S-9. Finance and Implementation, S-12
  - S-10. Summary Reference, S-13
- 1-1 CHAPTER 1 Introduction**
  - 1-1. Basic Concepts of BRT, 1-1
  - 1-2. Reasons for Implementation, 1-2
  - 1-3. State-of-the-Art Synthesis, 1-3
  - 1-4. Implications and Directions, 1-6
  - 1-5. Prospects, 1-8
  - 1-6. Chapter 1 References, 1-8
- 2-1 CHAPTER 2 Planning Considerations**
  - 2-1. System Development Process, 2-1
  - 2-2. Desirable Conditions for BRT, 2-4
  - 2-3. Objectives and Principles, 2-5
  - 2-4. System Concepts, 2-6
  - 2-5. Chapter 2 References, 2-6
- 3-1 CHAPTER 3 Running Ways**
  - 3-1. General Considerations, 3-1
  - 3-2. On-Street Running Ways, 3-8
  - 3-3. Off-Street Running Ways, 3-21
  - 3-4. Freeway Running Ways, 3-30
  - 3-5. Chapter 3 References, 3-42
- 4-1 CHAPTER 4 Traffic Engineering for BRT**
  - 4-1. Overview, 4-1
  - 4-2. Traffic Controls, 4-1
  - 4-3. Special Signage and Signal Displays, 4-4
  - 4-4. Signal Prioritization, 4-4
  - 4-5. Enforcement, 4-12
  - 4-6. Chapter 4 References, 4-14
- 5-1 CHAPTER 5 BRT Stations and Facilities**
  - 5-1. Systemwide Design and Urban Design Integration, 5-1
  - 5-2. Station Design, 5-3
  - 5-3. BRT Platform Characteristics, 5-5
  - 5-4. Station Configuration, 5-8
  - 5-5. Intermodal and Terminal Stations, 5-12
  - 5-6. Park-and-Ride Facilities, 5-16
  - 5-7. Ancillary Facilities, 5-17
  - 5-8. Chapter 5 References, 5-20
- 6-1 CHAPTER 6 BRT Vehicles**
  - 6-1. Capacity and Level of Service, 6-1
  - 6-2. Emissions, 6-15
  - 6-3. Guidance Systems, 6-16
  - 6-4. Image, 6-20
  - 6-5. Procurement Issues and Costs, 6-22
  - 6-6. Chapter 6 References, 6-23
- 7-1 CHAPTER 7 ITS Applications**
  - 7-1. Automatic Vehicle Location, 7-1
  - 7-2. Passenger Information Systems, 7-5
  - 7-3. Traffic Signal Priorities, 7-7
  - 7-4. Automatic Passenger Counters, 7-11
  - 7-5. Electronic Fare Collection Cards, 7-12



- 7-6. Vehicle Guidance, 7-14
- 7-7. Collision Avoidance Systems, 7-16
- 7-8. Bus Platoons, 7-16
- 7-9. Benefit and Cost Summary, 7-16
- 7-10. Costs, 7-18
- 7-11. Chapter 7 References, 7-18
- 8-1 CHAPTER 8 Bus Operations and Service**
  - 8-1. General Guidelines, 8-1
  - 8-2. Service Design, 8-1
  - 8-3. Fare Collection, 8-6
  - 8-4. Marketing BRT Service, 8-11
  - 8-5. Chapter 8 References, 8-16
- 9-1 CHAPTER 9 Financing and Implementing BRT Systems**
  - 9-1. General Guidelines, 9-1
  - 9-2. Benefits and Costs, 9-1
  - 9-3. Funding and Financing Options, 9-5
  - 9-4. Incremental Development of BRT Projects, 9-12
  - 9-5. Institutional Arrangements, 9-15
  - 9-6. BRT-Supportive Policies, 9-17
  - 9-7. Chapter 9 References, 9-19
- A-1 APPENDIX A: Bus Capacity**
- B-1 APPENDIX B: Pedestrian and Lighting Guidelines**
- C-1 APPENDIX C: Design Vehicle Characteristics**
- D-1 APPENDIX D: Details of Access Point Design**
- E-1 APPENDIX E: BRT Vehicle Technology Details**
- F-1 APPENDIX F: Comparison Tables of BRT Systems  
from Case Study Report**

# VOLUME 2: IMPLEMENTATION GUIDELINES

## SUMMARY

This report presents planning and implementation guidelines for bus rapid transit (BRT). The guidelines are based on a literature review and an analysis of 26 case study cities in the United States and abroad. The guidelines cover the main components of BRT—running ways, stations, traffic controls, vehicles, intelligent transportation systems (ITSs), bus operations, fare collection and marketing, and implementation.

### S-1. WHAT IS BRT?

BRT has been defined by the Federal Transit Administration as “a rapid mode of transportation that can provide the quality of rail transit and the flexibility of buses” (“BRT Reference Guide”). The following expanded definition has been used in developing the implementation guidelines presented here: BRT is a flexible, rubber-tired form of rapid transit that combines stations, vehicles, services, running ways, and ITS elements into an integrated system with a strong identity. BRT applications are designed to be appropriate to the market they serve and their physical surroundings, and they can be incrementally implemented in a variety of environments (from rights-of-way totally dedicated to transit—surface, elevated, underground—to mixed with traffic on streets and highways).

In many respects, BRT is rubber-tired light rail transit (LRT), but with greater operating flexibility and potentially lower costs. Often, a relatively small investment in dedicated guideways can provide regional rapid transit.

### S-2. PLANNING

BRT should be developed as an outgrowth of a planning and development process that stresses problems and demonstrated needs rather than solution advocacy. BRT calls for early and continuous community and decision-maker support. State, regional, and town cooperation is essential; transit planners, traffic engineers, and urban planners must work together.

A key issue, unique to BRT planning, is dealing with modal biases in the system-planning process and the perceived greater desirability of rail transit. Other issues, similar to planning for any rapid-transit mode, include finding suitable corridors for BRT,

obtaining street space for buses and sidewalk space for stations, achieving effective enforcement, and overcoming fragmentation of responsibilities and conservative agency attitudes.

Planning BRT projects calls for a realistic assessment of demands, costs, benefits, and impacts. The objective is to develop a coordinated set of actions that achieves attractive and reliable BRT services, serves demonstrated demands, provides reserve capacity for the future, attracts automobile drivers, relates to long-range development plans, and has reasonable costs. Key factors include the following:

- **Land Use:** the intensity and growth prospects of activity centers, urban growth and expansion, development and growth patterns, and locations of major employment centers and residential developments in relation to potential BRT routes.
- **Road Network:** street width continuity, capacity, congestion, and opportunities for off-street running ways.
- **Bus Operations:** past and future projected transit use, operating speeds, and reliability.

Community willingness to support public transport, foster transit-oriented development, and enforce bus lanes is essential; therefore, extensive and effective public participation in the decision-making process can facilitate BRT implementation.

A BRT plan should be developed as an integrated system that adapts attributes of rail transit, focuses on major markets, emphasizes speed and reliability, takes advantage of incremental development, and establishes complementary transit-first policies. Other system attributes that are equally important include the times during which service is available, frequency/headways, walking distances, waiting times, transfers, in-vehicle time, a clean and appealing image, and fare collection strategies. The elimination or reduction of system features to cut costs should be avoided.

BRT is especially desirable in large cities and urbanized areas where passenger flows need frequent service, and there is a sufficient “presence” of buses. The following generalized standards should be applied as a starting point for BRT planning and design:

- In the United States and Canada, BRT is typically most successful when the urban population exceeds 750,000 and employment in the central business district (CBD) is, at a minimum, between 50,000 and 75,000. Land uses should be organized in dense patterns that facilitate transit use.
- Desired service frequencies for a basic BRT line should be at least 8 to 10 minutes during peak periods and 12 to 15 minutes during off-peak periods to facilitate random passenger arrivals. These service frequencies translate into a daily ridership of at least 5,000.

BRT system design and operation should reflect the specific needs and opportunities of each urban area. They should enhance the presence, permanence, and identity of BRT facilities and services. The common types of BRT are (1) conventional radial routes, (2) extensions of rail rapid-transit lines, and (3) peak-period commuter express operations.

### S-3. RUNNING WAYS

Running ways are the key element of BRT systems around which the other components revolve. Running ways should allow rapid and reliable movement of buses with minimum traffic interference and provide a clear sense of presence and permanence.

Because buses have higher occupancies than private automobiles, economic benefits can result from increased ridership attraction, passenger time savings, and operating costs.

### S-3.1. General Guidelines

BRT may run in dedicated busways, in freeway rights-of-way, or on city streets. Table S-1 lists the common types of running ways and groups them by amount of access control. Some general guidelines are the following:

- **Running ways should serve and penetrate major travel markets.**
- **Running ways should serve the three basic route components of CBD distribution, line haul, and neighborhood collection in a coherent manner.** Generally, a variety of types of running ways will be used for each component and customized to specific needs. CBD distribution may be on street in bus lanes, off street in bus tunnels, or achieved by means of terminals; physically segregated busways or bus lanes will normally provide the line-haul service. Residential distribution may be via bus lanes or in mixed traffic. A dedicated BRT corridor may consist of a number of segments, each with a different running way treatment.
- **Running ways will generally be radial, connecting city centers with outlying residential and commercial areas.** BRT can also effectively connect major activity centers or corridors with dense development patterns that facilitate transit use. Cross-town running ways may be appropriate in large cities where they connect major passenger generators, serve large residential catchments, and cross frequent interchanging bus lines or rail lines.
- **BRT is best achieved by providing exclusive grade-separated right-of-way.** However, these rights-of-way may be difficult to obtain, costly to develop, and not always located in areas of the best ridership potential. Therefore, street running ways or at-grade intersections in an otherwise exclusive or separated running way may be required.
- **Effective downtown passenger distribution facilities are essential.** In providing the more direct, off-guideway service to downtown origins and destinations, the downtown distribution system should maintain service dependability and minimize time losses resulting from general traffic delays.
- **BRT running ways should follow streets and roadways that are relatively free flowing wherever possible.** Speeds and reliability should be enhanced by

**TABLE S-1 Running ways classified by extent of access control**

Class	Access Control	Facility Type
I	Uninterrupted Flow Full Control of Access	Bus Tunnel Grade-Separated Busway Reserved Freeway Lanes
II	Partial Control of Access	At-Grade Busway
III	Physically Separated Lanes Within Street Rights-of-Way	Arterial Median Busway Bus Street
IV	Exclusive Semi-exclusive Lanes	Concurrent and Contra Flow Bus Lanes
V	Mixed Traffic Operations	

transit-sensitive traffic engineering, provisions of bus-only lanes, and, in some cases, major street improvements. Routes should be direct, and the number of turns should be minimized.

- Special running ways (e.g., busways, bus lanes, and queue bypasses) should be provided when there is (1) extensive street congestion; (2) a sufficient number of buses; (3) suitable street geometry; and (4) community willingness to support public transport, reallocate road space as needed, provide necessary funding, and enforce regulations.
- **Preferential treatments for BRT may be provided (1) around specific bottlenecks or (2) along an entire route.** Queue bypasses or queue jumpers are very effective on approaches to water crossings with extensive peak-hour congestion. Longer treatments are desirable along BRT routes.
- **Running ways should maximize the person flow along a roadway with minimum net total person delay over time.** There should be a net savings in the travel time per person for all travelers. When road space is allocated to BRT, the person minutes saved should be more than the person minutes lost by people in automobiles.
- **Buses should be able to enter and leave running ways safely and conveniently.** This is especially important in developing median and contra flow lanes and busways along arterial streets and within freeway corridors. There should be suitable provisions for passing stopped or disabled buses.
- **Running ways should provide a strong sense of identity for BRT.** This is especially important when buses operate in bus lanes or in arterial median busways. Giving the lanes a special color is also recommended.
- **Adequate signing, markings, and traffic signal controls are essential.** They are especially important at entry and exit points of arterial contra flow bus and median busways, bus-only streets, busways, and reserved freeway lanes.
- **Bus lanes and queue bypasses may be provided along both one-way and two-way streets.** Although subject to unique local roadway conditions, generally, concurrent flow bus lanes should allow at least two adjacent general traffic lanes in the same direction of travel. Contra flow lanes should allow at least two traffic lanes in the opposite direction of travel. Median arterial busways should allow at least one travel lane and one parking lane in each direction. In restrictive situations, there should be at least one through and one left-turn lane each way on two-way streets.
- **Running way designs should be consistent with established national, state, and local standards.** The stops and stations should be accessible to all likely users. They should permit safe bus, traffic, and pedestrian movements.
- **Running way designs may allow, when feasible, possible future conversion to rail transit without disrupting BRT operations.** Service during the construction period is desirable for median arterial busways, busways on separate rights-of-way, and busways within freeway envelopes.

### S-3.2. Capacities

The number of buses and passengers that can be carried along a BRT route depends on the type of running way, the design of stations and stops, the size and height of buses, door arrangements on buses, fare collection methods, demand characteristics (e.g., the concentration of boardings at critical stops), and operating practices. Experience with BRT in several cities around the world suggests the following:

- When buses operate nonstop along freeways, have well-designed entry points, and have adequately sized terminals, flows up to about 750 buses per lane per hour have been accommodated.

- Busways with passing lanes at stations carry over 200 buses per hour each way, but this requires adequate capacity such as dual bus lanes in downtown areas for buses.
- The South American experience indicates that median arterial busways can carry over 200 buses per hour each way with passing lanes at stations.
- Dual bus lanes on downtown streets carry a total of 150 to 200 buses per hour. Similar volumes can be carried in a single lane with more infrequent stops if there is multidoor boarding and use of off-board fare collection and/or noncash fares.
- Curb bus lanes on city streets typically can accommodate 90 to 120 buses per hour.

Given the above information on capacities (based on experience with BRT systems around the world), it is safe to say that BRT generally can provide sufficient capacities for corridors in most U.S. cities.

### S-3.3. On-Street Running Ways

On-street BRT running ways provide downtown and residential distribution and serve corridors where market factors, costs, or right-of-way availability preclude providing busways (or reserved freeway lanes). On-street running ways also may be the first stage of future off-street BRT development and establish ridership during an interim stage. Each type of on-street running way has its strengths and weaknesses:

- *BRT operations in mixed traffic flow* can be implemented quickly at minimum cost, but can subject buses to general traffic delays, and there is little or no sense of BRT identity.
- *Concurrent flow curb bus lanes* are easy to install, their costs are low, and they minimize the street space devoted to BRT. However, they are usually difficult to enforce and are the least effective in BRT travel time saved. Conflicts between right-turning traffic and pedestrians may delay buses.
- *Contra flow curb lanes* enable two-way operation for buses on one-way streets, may increase the number of curb faces available for passenger stops, completely separate BRT from general traffic flow, and are generally self-enforcing. However, they may disperse BRT onto several streets, thereby reducing passenger convenience. Contra flow curb lanes require buses to run against the prevailing traffic signal progression, limit passing opportunities around stopped or disabled buses (unless multiple lanes are provided), conflict with opposing left turns, and may create safety problems for pedestrians.
- *Concurrent flow interior bus lanes* remove BRT from curbside frictions, allow curb parking to be retained, and provide far-side bus “bulbs” at stops for passenger convenience. However, they generally require curb-to-curb street widths of 60 to 70 feet, and curb parking maneuvers could delay buses.
- *Median arterial busways* physically separate the BRT running ways from general traffic, provide a strong sense of BRT identity, eliminate conflicts between buses and right-turning automobiles, and can enable the busways to be grade separated at major intersections. However, they require prohibiting left turns from the parallel roadways or providing special lanes and signal phases for these turns. Median arterial busways also require wide streets—generally more than 80 feet curb to curb, and their costs can be high.
- *Bus-only streets* remove BRT from general traffic, increase walking space for pedestrians and waiting space at stations, improve BRT identity, and improve the ambience of the surrounding areas. However, they need nearby parallel streets for the displaced traffic and provisions for goods delivery and service access from cross streets or off-street facilities. They are generally limited to a few city blocks.

Key guidelines for planning and implementing on-street running ways are as follows:

- **General traffic improvements and road construction should be coordinated with BRT service to improve the overall efficiency of street use.** Typical improvements include prohibiting curb parking, adding turning lanes, prohibiting turns, modifying traffic signal timing, and providing queue bypasses for buses.
- **Curb parking generally should be prohibited before (curb) bus lanes are established, at least during peak hours.** The prohibition (1) provides a bus lane without reducing street capacity for other traffic, (2) reduces delays and marginal frictions resulting from parking maneuvers, and (3) gives buses easier access to stops.
- **Bus routes should be restructured as necessary to make effective use of bus lanes and bus streets.** When BRT vehicles exceed 40 buses per hour, they should have exclusive use of the running way. When service is less frequent, it may be desirable to operate local buses on the same facility; this should not create bus-bus congestion or create passenger inconvenience.
- **Bus priority treatments should reduce both the mean and variability of average journey times.** A 10 to 15% decrease in bus running time is desirable.
- **Extended bus lanes are necessary to enable BRT schedule speeds to achieve significant time savings, better service, reliability, and increased ridership.** A time savings of 1 minute per mile (equivalent to raising bus speeds from 10 to 12 miles per hour) could produce a 5- to 6-minute time savings, if achieved over the entire length of a typical 5-mile bus journey.
- **Police cars, fire equipment, ambulances, and maintenance vehicles should be allowed to use bus lanes and bus streets.**
- **Design and operation of bus lanes must accommodate the service requirements of adjacent land uses.** Deliveries should be prohibited from curb bus lanes during the hours that the lanes operate; deliveries can be provided from the opposite side of the street, from side streets, or, ideally, from off-street facilities. Accommodating deliveries is especially important when contra flow lanes are provided.
- **Access to major parking garages should be maintained.** This may require limited local automobile circulation in blocks adjacent to garages.
- **Taxi loading areas should be removed from bus lanes.** On one-way streets, the taxi loading areas should be placed on the opposite side of the street from the bus lane.
- **Access to bus stops and stations should be convenient and safe.** Curbside stops should allow sufficient space for amenities within the stop or in the adjacent sidewalk. Crosswalks to reach median bus lanes and busways should be placed at signalized locations wherever possible and should be designed to discourage errant crossings.
- **Running way design should reflect available street widths and traffic requirements.** Ideally, bus lanes should be provided without reducing the lanes available to through traffic in the heavy direction of flow. This may entail eliminating parking or reducing lane widths to provide additional travel lanes, eliminating left-turn lanes, and/or providing reversible lane operation.
- **When buses preempt moving traffic lanes, the number of lanes taken should be kept to a minimum.** The exception is when parallel streets can accommodate the displaced traffic.
- **Bus lanes and streets should provide a strong sense of identity.** This can be achieved by using colored pavement wherever buses have exclusive use of the lanes. Such treatments are especially important for curb bus lanes when the lanes operate at all times.

- **Effective enforcement and maintenance of bus lanes and bus streets is essential.** Fines for unauthorized vehicles should be high enough to discourage illegal use.
- **BRT bus lanes (and streets) should operate all day whenever possible.** This will give passengers a clear sense of bus-lane identity and make use of specially colored pavements easier.
- **Generally, far-side bus stops should be provided.** They are essential when there are traffic signal priorities for buses and along median arterial busways where left-turn lanes are located near-side. Far-side bus stops are desirable where curb lanes are used by moving traffic and at locations with heavy right-turn traffic.
- **BRT lane widths should accommodate the anticipated BRT fleet.** Concurrent flow bus lanes should be at least 11 feet wide for 8.5-foot-wide buses (including mirrors); 12- to 13-foot-wide bus lanes are desirable. Contra flow bus lanes should be at least several feet wider to provide a cushion between the bus lanes and opposing traffic and to let buses pass around errant pedestrians in the lanes. Bus streets and arterial median busways should be at least 22 feet wide.
- **Bus lanes in the center of streets should be physically separated from other traffic.** These *median arterial busways* will require curb-to-curb roadway widths of at least 75 to 80 feet.
- **Bus lanes and bus streets must be perceived as reasonable by users, public agencies, and the general public.** An exclusive bus lane should carry more people than it would if the lane were used by general traffic.

#### S-3.4. Off-Street Running Ways

Off-street BRT running ways for line-haul BRT operations can permit high speeds and minimize traffic interferences. A desirable goal is to provide as much of the BRT route mileage in reserved freeway lanes or special busways as possible. The following considerations should underlie BRT development in special bus-only roads and in freeway corridors:

- **Rapid and reliable BRT service is best achieved when buses operate in dedicated busways or reserved lanes in freeway rights-of-way.** Busways have the advantages of better penetration of markets, closer relationship of stations to surrounding areas, better opportunities for transit-oriented development, and a stronger sense of identity.
- **BRT access to freeways will benefit from bus-only ramps and/or metered ramps with bus bypass lanes.** These ramps have the dual benefits of reducing bus delays and/or improving main-line flow.
- **Ideally, busways should penetrate high-density residential and commercial areas, traverse the city center, and provide convenient distribution to major downtown activities.** Busways should minimize branching to simplify route structure and station berthing.
- **Busways should be located on their own rights-of-way whenever possible.** Locations in order of desirability are (1) separate right-of-way, (2) one side of a freeway right-of-way, and (3) within freeway medians.
- **Railroad and freeway rights-of-way offer opportunities for relatively easy land acquisitions and low development costs.** However, the right-of-way availability should be balanced with its proximity and access to key transit markets. Such rights-of-way may generate little walk-on traffic, limit opportunities for land development, and require complex negotiations.



- **It is generally preferable that downtown off-street busway distribution provide at least three stops at ¼- to ½-mile intervals.** This is essential to avoid concentrating all boardings and alightings at one location with attendant increases in bus dwell times.
- **Busways should enable express BRT services to pass around stopped buses at stations.** This increases service flexibility, reliability, and capacity, and it would result in cross sections of about 50 to 80 feet at stations.
- **Busways could be designed to allow for possible future conversion to rail or other fixed guideway transit.** A 60-foot, mid-station, right-of-way width and an 80-foot width at stations can allow BRT service during the conversion period.
- **Busway stations should be accessible by foot, automobile, and/or bus.** These should be placed at major traffic generators and at intersecting bus lines. Park-and-ride facilities should be provided in outlying areas where most access is by automobile.
- **Busways can be provided as part of new town developments (e.g., Runcorn) or serve as an access framework for still-to-be-developed areas.** This makes land acquisition easier and encourages transit-oriented development.
- **Busways may operate *normal flow* (with shoulders provided whenever possible), *special flow* (with a central shoulder or passing lane), or *contra flow* (with a central shoulder passing lane).** Normal flow designs are the simplest, safest, and most common. Contra flow configurations permit common center-island station platforms that minimize station stairways, supervision, and maintenance requirements; however, they require crossovers at beginning and end points if buses with doors on only one side are used.
- **Car pools and van pools may sometimes share bus-only lanes and busways along freeways.** However, this should happen only when bus volumes are low, there are no (or few) stations, and the high-occupancy vehicles (HOVs) do not impede bus movements. Generally, bus-only facilities are preferable from a standpoint of service reliability and identity.
- **Special BRT facilities along freeways are essential whenever congestion is prevalent.** The identification of major overload points along freeways is an important first step in identifying where special BRT facilities should be provided.
- **Bus lanes generally should extend at least 5 miles to allow buses to run non-stop.** The principal exceptions are “queue bypass” lanes, which are common on approaches to river crossings (e.g., the New Jersey Route 3 contra flow lane on the approach to the Lincoln Tunnel).
- **Existing freeway lanes in the heavy direction of travel should not be converted to bus lanes.** It is better to provide additional lanes for this purpose so as not to make general traffic congestion worse.
- **Standardization of freeway entrance and exit ramps to the right of the through traffic lanes permits use of median lanes by buses either in concurrent (normal) or contra (reverse) flows.** Special bus entry and exit ramps to and from the median lanes should be provided as needed so buses do not have to weave across the main travel lanes.
- **Both median and right-side bus lanes are in operation.** Median lanes are removed from ramp conflicts at interchanges and can allow special median access to crossroads. However, they require careful design of access points to avoid weaves across the general traffic lanes. Right-shoulder lanes allow easy bus entry and exit. However, they result in frequent weaving conflicts, especially when crossroad entry and exit ramps are closely spaced.

- **When a BRT commuter express service (such as in Houston) operates on an HOV facility, it is essential that the BRT service have its own access/egress ramps to off-line transit stations and/or to its park-and-ride facility.** Residential off-line collection should be done without requiring vehicles to weave across general traffic lanes to enter and leave the facility.
- **Running ways should be wide enough to enable buses to pass stalled or disabled vehicles without encroaching on opposing lanes.**

#### **S-4. TRAFFIC ENGINEERING**

The specific traffic engineering techniques required for BRT running ways vary with the type and location of BRT running ways. They generally include (1) curb adjustments, changes in roadway geometry, and pavement markings; (2) curb parking and loading controls; (3) left- and right-turn controls; (4) one-way street routings; (5) and traffic signal controls including BRT priorities. They apply wherever BRT operates and interfaces with roads and streets, if only at intersections. The general goals are to (1) minimize delays along roadways for both buses and automobiles, (2) ensure safe and reliable pedestrian access to BRT stops, and (3) maintain essential access to curbside activities.

Enforcement should be done by the jurisdictions that have primary responsibility for the BRT running ways. It should be done on a sustained basis, and penalties for violations (e.g., fines and towing) should be stringent.

#### **S-5. STOPS, STATIONS, AND TERMINALS**

Bus stops, stations, terminals, and associated facilities such as park-and-ride lots form the interface between passengers and the BRT system. They should be permanent, weather-protected facilities that are convenient, comfortable, safe, and accessible to passengers with disabilities. These facilities should support a strong and consistent identity for BRT in the community, while respecting and enhancing the surrounding urban context.

BRT facilities should be viewed as urban-design assets. Integration of a BRT guideway into an urban setting presents an opportunity to improve and enrich streetscapes by incorporating new amenities such as landscaping and recreational trails. Because guideway construction may displace lighting, sidewalks, and street furniture, these elements can and should be reconstructed or replaced so as to reinforce new, unified design themes.

Station development calls for high-quality designs and passenger amenities; establishing consistent themes of form, material, and color for stations and other BRT elements; context-sensitive design; and relating BRT stations to adjacent land uses.

Key BRT station concepts and guidelines are the following:

- **Provide a full range of amenities at stations, including shelters, passenger information, telephones, lighting, and security provisions.**
- **Design for station access by customers who have disabilities.**
- **Provide a consistent pattern of station location, configuration, and design to the maximum extent practical.**
- **Separate BRT, local buses, automobiles, and pedestrian movements in station design.**
- **Coordinate station platform design with vehicles and fare collection policies.**

- **Ensure that station configurations support the service plan and operating philosophy of the BRT route.** Provide bypass capabilities when express and local BRT services are provided on the same running way.
- **Size station berths, platforms, and access facilities to serve the expected number of riders without overcrowding or spillback, to provide capacity for future growth, and to achieve reasonable levels of service.**
- **Increase berth capacity by fostering fare prepayment and/or multidoor boarding.**
- **Ensure that station locations and designs are developed cooperatively with the surrounding community.**
- **Provide far-side stops where running ways cross streets at grade.**
- **Provide convenient transfers between BRT and intersecting transit routes.** Place BRT and local bus stops in separate areas when both services use a common route, but allow for convenient transfers between them.
- **For routes that terminate at the station, allow independent bus arrivals and departures at major transit centers and bus terminals.**

## S-6. VEHICLES

BRT vehicles should be carefully selected and designed because of their impacts on travel times, service reliability, and operating/maintenance costs; their impacts on the environment; and their identity and appeal to passengers. They should be customized for the markets that they will serve. They should use body styles and propulsion systems that have been proven in revenue service.

The desired features of BRT vehicles include the following:

- **Vehicles should provide sufficient passenger capacity for anticipated ridership levels.** They may be standard 40-foot or articulated 60-foot buses for main-line service or smaller buses for collector/distributor service.
- **Vehicles should be easy to board and alight.** This can be achieved by using low-floor buses with floor heights 12 to 15 inches above street level and using wide, multistream doors. Buses using high platforms at stations can also speed boarding, but they may require precise docking; they are only practical when operating flexibility is not limited.
- **A sufficient number of doors should be provided, especially when coordinated with off-vehicle fare collection.** Generally, about one door channel should be provided for each 10 feet of vehicle length (e.g., two double-stream doors for a 40-foot bus). Providing doors on both sides of buses (as with light rail vehicles) enables both center-island and side station platforms to be used.
- **Internal vehicle design generally should maximize the number of people each bus can carry, rather than the number of seated passengers.** This is less relevant for routes with long person trips, on which vehicles should accommodate as many seated passengers as possible.
- **Wide aisles should be provided to maximize internal circulation space.** The minimum aisle width of 34 inches on some specialized BRT vehicles is preferable to the 24-inch width used on most North American buses.
- **Bus propulsion systems should be “environmentally friendly” by minimizing air pollution and noise.** Conventional diesel buses can reduce emissions by using catalytic converters and ultra-low-sulfur fuel. Other low-pollution options include compressed natural gas (CNG) diesel-electric hybrids, electric trolley buses, and dual mode trolley/diesel propulsion.

- **Vehicles should have a distinctive BRT identity and image.** They should be clearly marked or “branded” to convey the BRT theme. Ideally, BRT routes should only be served by dedicated BRT vehicles.
- **Vehicles should have a high passenger appeal and give passengers a comfortable ride.** Desirable features include air conditioning, lighting, panoramic windows, automated station announcements, and upholstered seats.
- **Vehicles should be reliable, with a long mean distance between failures.**
- **Life service costs should be reasonable; the cost of acquiring and operating buses should be reasonable.** Conventional articulated buses cost about \$400,000 to \$600,000 and have a 12- to 15-year design service life as compared with some of the BRT “purpose-built” vehicles that cost about \$1 million and have an 18- to 25-year design life.

Existing BRT vehicles range from conventional single unit and articulated buses to “special purpose” vehicles that resemble light rail vehicles. They include articulated low-floor vehicles (conventional) and specialized BRT vehicles. BRT vehicles may also have automated, multi-axle, rear-wheel, steering systems that permit precise docking at stations.

## **S-7. INTELLIGENT TRANSPORTATION SYSTEMS**

ITSS can play an important role in providing fast, safe, and reliable BRT. They can monitor bus operations, give real-time information to passengers, provide accessible information for patrons with hearing or visual impairments, provide priority for BRT at signalized intersections, expedite fare collection, and allow precise docking at stations.

### **S-7.1. Automatic Vehicle Location (AVL) Systems**

AVL systems pinpoint bus locations on the street network, improve bus dispatch and operation, and allow quicker response to service disruptions and emergencies. Both capital and operating cost savings have been reported by transit agencies using AVL. AVL systems can provide dynamic real-time information to passengers before a trip, at platforms, and/or on vehicle.

### **S-7.2. Traffic Signal Priority Systems**

Traffic signal priority systems for BRT increasingly rely on global positioning systems to identify bus locations. This enables the priorities to be integrated with the master Urban Traffic Control Systems. Advancing or extending the green can be unconditional or conditional (e.g., applied only when buses run late). Overall route travel time reductions of up to 10% are common. Priority systems also have reduced the range (variability) in bus delays, thereby increasing reliability.

### **S-7.3. Automatic Passenger Counters**

These applications have reduced the costs of ride checks associated with planning and monitoring service.

### **S-7.4. Electronic Fare Collection**

Electronic fare collection can reduce dwell times and driver distraction, help reduce fare collection costs, and increase revenues. Electronic fare collection can be implemented with magnetic systems that use stripe cards, smart cards, and/or debit cards.

### S-7.5. Bus Guidance Technologies

Guidance technologies can control the position of buses in travel lanes, improve safety, and allow precise docking at stations. Guidance may be mechanical (e.g., the systems operating in Leeds, United Kingdom; Adelaide, Australia; and Nancy, France); optical (e.g., the Rouen, France system); or magnetic (e.g., the system in Eindhoven, Netherlands).

### S-8. SERVICE, FARES, AND MARKETING

BRT service should be clear, direct, frequent, and rapid. Fare collection should permit rapid boarding of buses. Marketing should focus on BRT's unique features and further reinforce its identity. General guidelines are the following:

- **Service patterns and frequencies should reflect the types of running way, city structure, potential markets, and available resources.** Buses may run totally or partially on dedicated rights-of-way when such running ways are available.
- **Service should be simple, easy to understand, direct, and operationally efficient.** Providing point-to-point, one-seat rides should be balanced against the need for easy-to-understand, high-frequency service throughout the day. It is generally better to have a few high-frequency BRT routes rather than many routes operating at long headways.
- **Busway route structure should include a combination of basic all-stop service that is complemented by express (or limited-stop), feeder, and connector service.** The all-stop service can run all day, from about 6 a.m. to midnight, 7 days a week, and the express service should operate weekdays throughout the day or just during rush hours. The basic BRT all-stop service should operate at 5- to 10-minute intervals during rush hours and 12- to 15-minute intervals at other times.
- **BRT running ways may be used by all transit operators in a region where vehicles meet established safety requirements.** BRT vehicles can share running ways with HOVs in reserved freeway lanes when the joint use does not reduce travel times, service reliability, and BRT identity.
- **Running times and average operating speeds should be maximized by providing wide station spacing and by reducing dwell times at stops.**
- Fares should be integrated with the rest of the bus system, but they may not necessarily be the same.
- **Fare collection systems should facilitate multiple-door boarding, at least at major stops during busy periods.** Off-board collection (preferred) or on-board multipoint payment should be encouraged.
- **Marketing should emphasize the unique features of BRT such as speed, reliability, service frequency and span, and comfort.** It should create a unified system image and identity that clearly "brands" BRT. Distinctive logos, color combinations, and graphics should be applied to vehicles and used at stations and on printed materials.

### S-9. FINANCE AND IMPLEMENTATION

Implementing BRT calls for a clear understanding of its benefits, costs, and financing mechanisms. Priorities should reflect needs and resources, with each stage containing a meaningful package of BRT features. Public agencies should work together

in making BRT a reality and creating a transit-supportive environment. Some guidelines are the following:

- **BRT systems should be integrated with other transit services in terms of routes, fares, service coordination, and marketing efforts.**
- **Overall system benefits resulting from travel time savings, operating cost savings, and land development increase with operating speed.** When travel time savings are substantial and market conditions are right, BRT can generate substantial new ridership and land development benefits. However, high speeds usually require busways, which may have high development costs.
- **Systems can be financed through combinations of federal, state, and local funding sources.** Value capture, benefit assessments, and other public-private arrangements may provide additional funding in special circumstances such as around major stations.
- **Although most systems are developed by traditional design-bid-build arrangements, innovative project delivery arrangements may be feasible.** Design-build-operate-maintain project delivery strategies may be appropriate for major projects with widespread system benefits.
- **BRT is well suited for incremental development because of its operating flexibility.** Each stage should contain a well-packaged series of BRT elements. Early action and early successes are essential to maintain community interest and support. Busways can be designed to allow possible future conversion to rail as needs arise or ridership warrants.
- **Transit agencies, city transportation departments, and state agencies must work together in planning, designing, and maintaining BRT systems.** Close cooperation and coordination are essential.
- **Parking and land use policy should reinforce BRT operations by fostering transit-oriented development and limiting downtown parking.**
- **BRT should be viewed as an important community asset that improves mobility and contributes to more livable and vital urban areas.**

#### S-10. SUMMARY REFERENCE

“BRT Reference Guide.” *Bus Rapid Transit*. Federal Transit Administration, U.S. Department of Transportation. [www.fta.dot.gov/brt/guide/index.html](http://www.fta.dot.gov/brt/guide/index.html)

---

## CHAPTER 1

# INTRODUCTION

This second volume of *TCRP Report 90: Bus Rapid Transit* presents planning and implementation guidelines for bus rapid transit (BRT). The guidelines are based on a literature review and an analysis of 26 case study cities in the United States and abroad. This is the third of three documents covering TCRP Project A-23, “Planning and Implementation Guidelines for Bus Rapid Transit.” The first document, “BRT—Bus Rapid Transit—Why More Communities Are Choosing Bus Rapid Transit,” an informational brochure, was published in 2001. The second document is the first volume of *TCRP Report 90: Bus Rapid Transit*, published in July 2003. In addition, the project team compiled a video library of BRT and an extensive annotated bibliography of previous research on BRT.

The guidelines presented in this volume are intended to assist transportation practitioners with planning and implementing BRT systems. The guidelines cover the main components of BRT—running ways, stations, traffic controls, vehicles, intelligent transportation systems (ITSs), bus operations, fare collection and marketing, finance, implementation, and staging. The guidelines also cover the packaging of these elements into a permanently integrated unit that characterizes BRT. This volume is organized as follows:

- Chapter 1 describes basic BRT concepts, the reasons for BRT implementation, and the key findings of the 26 BRT case studies.
- Chapter 2 sets forth general planning considerations, key issues and concerns, the system development process, desirable conditions for BRT, general planning principles, and an overview of system types.
- Chapter 3 describes the various types of running ways.
- Chapter 4 contains traffic engineering treatments for BRT.
- Chapter 5 gives guidelines for stops, stations, and terminals.
- Chapter 6 gives salient information on vehicle types and features.
- Chapter 7 discusses the application of ITSs.
- Chapter 8 covers bus operations, including service patterns, fare collection, and marketing.
- Chapter 9 presents key implementation considerations, including benefits and costs, financing, institutional and public policy issues, and incremental development or staging of BRT systems.
- Appendixes A through F (which have not been edited by TRB) contain supporting materials.

The guidelines focus on North American practice. However, many aspects also apply to BRT development in other countries.

### 1-1. BASIC CONCEPTS OF BRT

There is a broad range of perspectives as to what constitutes BRT. The Federal Transit Administration, for example, defines BRT as “a rapid mode of transportation that can combine the quality of rail transit and the flexibility of buses” (Thomas, 2001). The following definition of BRT has been used in developing the guidelines presented here: BRT is a flexible, rubber-tired form of rapid transit that combines stations, vehicles, services, running ways, and ITS elements into an integrated system with a strong identity. BRT applications are designed to be appropriate to the market they serve and their physical surroundings, and they can be incrementally implemented in a variety of environments (from rights-of-way totally dedicated to transit—surface, elevated, underground—to mixed with traffic on streets and highways).

In many respects, BRT is rubber-tired light rail transit (LRT), but with greater operating and implementation flexibility and potentially lower costs. Often, a relatively small investment in a dedicated guideway can support regional rapid transit. This definition has the following implications:

- BRT is operated with steerable, rubber-tired vehicles capable of on- as well as off-guideway operation. This can provide greater operating flexibility and potentially lower capital and operating costs than rail transit.
- When BRT vehicles (buses) operate totally on exclusive or protected rights-of-way (surface, elevated, and/or tunnel) with on-line stops, the service provided is similar to rail rapid transit.
- When buses operate in combinations of exclusive rights-of-way, median reservations, bus lanes, and street running with on-line stops, the service provided is similar to LRT.
- When BRT operates almost entirely on exclusive bus or HOV lanes on highways (freeways and expressways), to and from transit centers with significant parking, and with frequent levels of peak service focused on a traditional Central Business District (CBD), it is similar to commuter rail.

- When buses operate mainly on city streets, with little or no special signal priority or dedicated lanes, the service provided is similar to an upgraded limited-stop bus or tram system.

The major components of BRT are planned with the objective of improving the key attributes of speed, reliability, and identity. Collectively, as an integrated package, they form a complete rapid-transit system with significant customer convenience and transit level of service benefits (“BRT-Bus Rapid Transit,” 2001).

## 1-2. REASONS FOR IMPLEMENTATION

Transportation and community-planning officials all over the world are examining public transportation solutions to improve urban mobility and contain urban sprawl. These concerns have led to the reexamination of existing transit technologies and the development of new, creative ways to improve transit service and performance. BRT is seen as a cost-effective means of achieving these objectives. BRT can be built in stages, requires shorter planning and construction time frames, and has lower costs and greater flexibility than LRT. In addition, it can be built in any environment where LRT runs.

For most intermediate capacity rapid-transit applications now being considered in North America, bus-based rapid transit has the potential to offer capacities and a level of service that are comparable to rail systems in many respects, superior in some respects, and characterized by both operating and capital costs that (depending on passenger volumes) will generally be considerably lower.

Specific reasons for implementing BRT are the following:

- Continued growth of urban areas, including many CBDs and suburban and regional centers, requires more transport service and improved access. Given the costs and community impacts associated with major road construction, improved and expanded public transport emerges as an important way to provide the needed capacity. However, existing bus systems are difficult to use; service is slow, infrequent, and unreliable; route structures are complex and hard to understand; vehicles and operations are not well matched to markets; and there is little, if any, passenger information and few amenities at stops. Rail transit can be difficult, time consuming, and expensive to implement; costly to operate; and poorly suited to many contemporary U.S. travel markets.
- BRT can often be implemented quickly and incrementally, without precluding future rail investment if and when it is warranted.
- For a given distance of dedicated running way, BRT is generally less costly to build and equip than rail transit.

Moreover, there are relatively low facility costs where buses operate in existing bus-only lanes or HOV lanes.

- BRT can be cost-effective in serving a broad variety of contemporary U.S. urban and suburban environments. BRT vehicles, whether driver-steered or guided mechanically or electronically, can operate on streets and in free-way medians, railroad rights-of-way, and arterial structures, as well as underground. BRT can easily provide a broad array of direct express, limited-stop, and local all-stop services on a single facility. Rail systems, with their large basic service units, must often force multiple transfers to serve the same markets.
- BRT can provide quality performance with sufficient transport capacity for corridor applications in most U.S. and Canadian cities. (The Ottawa Transitway system’s West Line, for example, carries more people in the peak-hour peak direction than most LRT segments in North America). Many BRT lines in South American cities carry peak-hour passenger flows that equal or exceed those on many U.S. and Canadian fully grade-separated rapid-transit lines.
- At the ridership levels typically found in most urban corridors, BRT’s relatively low marginal fixed and maintenance costs can offset variable driver costs to provide low net-unit operating and maintenance costs.
- BRT is well suited to extend the reach of existing rail transit lines. BRT can also provide feeder services to/from areas where densities are currently too low to support rail transit.
- BRT, like other forms of rapid transit, can be integrated into urban and suburban environments.
- The application of several ITS and other modern technologies makes BRT even more attractive and practical than earlier bus-based rapid-transit systems. These technologies include
  - “Clean” vehicles (e.g., those powered by electronically controlled “clean,” quiet diesel engines with catalytic converters, compressed natural gas [CNG], hybrid-“clean” diesel electric, or dual power, such as trolley/diesel);
  - Low-floor vehicles that allow quick, level boarding; and
  - Mechanical, electronic, and optical guidance systems.

The *main reasons* cited in the case studies (presented in Volume 1 of *TCRP Report 90*) for implementing BRT were lower development costs and greater operating flexibility as compared with rail transit. Other reasons included BRT as a practical alternative to major highway reconstruction, an integral part of the city’s structure, and a catalyst for re-development. A 1998 study in Eugene, Oregon, for example, found that a bus-based system could be built for about 4% of the cost of rail transit. However, in Boston, BRT was selected because of its operational and service benefits rather than its cost advantages.



### 1-3. STATE-OF-THE-ART SYNTHESIS

A synthesis of the experiences of 26 urban areas in North America, Australia, Europe, and South America follows (Levinson et al., 2002) Most of these systems are in revenue service; a few are under construction or development.

#### 1-3.1. Location

The locations, urban populations, rail transit availability, and development status of the 26 study cities are shown in Table 1-1. They include 12 urban areas in the United States (Boston, Charlotte, Cleveland, Eugene, Hartford, Honolulu, Houston, Los Angeles [3 systems], Miami, New York [2 sys-

tems], Pittsburgh, and Seattle); 2 cities in Canada (Ottawa and Vancouver); 3 cities in Australia (Adelaide, Brisbane, and Sydney); 3 cities in Europe (Leeds, Runcorn, and Rouen); and 6 cities in South America (Belo Horizonte, Bogotá, Curitiba, Porto Alegre, Quito, and São Paulo).

#### 1-3.2. Features

The main features of BRT include dedicated running ways; attractive stations; distinctive, easy-to-board vehicles; off-vehicle fare collection; use of ITS technologies; and frequent all-day service (typically between 5 a.m. and midnight). Table 1-2 summarizes BRT features by continent for systems in the 26 cities analyzed.

**TABLE 1-1 Case study locations**

CASE STUDY LOCATION	URBANIZED AREA POPULATION (MILLIONS)	RAIL TRANSIT IN METRO AREA?
<b>NORTH AMERICA</b>		
Boston, MA	3.0	√
Charlotte, NC	1.4	
Cleveland, OH	2.0	√
Eugene, OR (Lane Transit District)	0.2	
Hartford, CT	0.8	
Honolulu, HI	0.9	
Houston, TX	1.8	
Los Angeles County, CA <sup>a</sup>	9.6	√
Miami, FL	2.3	√
New York, NY	16.0	√
Ottawa, ON <sup>b</sup>	0.7	√
Pittsburgh, PA	1.7	√
Seattle, WA	1.8	
Vancouver, BC	2.1	√
<b>AUSTRALIA</b>		
Adelaide	1.1	√
Brisbane	1.5	√
Sydney	1.7	√
<b>EUROPE</b>		
Leeds, United Kingdom	0.7	
Rouen, France	0.4	√
Runcorn, United Kingdom	0.1	
<b>SOUTH AMERICA</b>		
Belo Horizonte, Brazil	2.2	√
Bogotá, Colombia	5.0	
Curitiba, Brazil	2.6	
Porto Alegre, Brazil	1.3	√
Quito, Ecuador	1.5	
São Paulo, Brazil	8.5	√

<sup>a</sup>Urbanized area population exceeds 15 million.

<sup>b</sup>Urbanized area population exceeds 1 million when Hull, Quebec, is included.

**TABLE 1-2 Number of facilities with specific features**

Feature	US / Canada	Australia & Europe	South America	Total Systems	Percent of Total
Running Way	13	5	6	24	83
Stations	12	4	3	19	66
Distinctive Vehicles	7	1	3	11	38
Off-Vehicle Fare Collection	2	0	3	5	17
ITS	7	1	3	11	38
Frequent All-day Service	11	5	6	22	76
<b>Total Systems</b>	<b>17</b>	<b>6</b>	<b>6</b>	<b>29</b>	<b>100</b>

SOURCE: Levinson et al., 2003.

Over 80% of the systems have some type of exclusive running way—either a bus-only road or a bus lane. More than 75% provide frequent all-day services, and about 66% have “stations” rather than stops. In contrast, only about 40% of the systems have distinctive vehicles or ITS applications, and only 17% (five systems) have or will have off-vehicle fare collection. Three existing systems have all six basic features: Bogotá’s TransMilenio, Curitiba’s median busways, and Quito’s Trolebus. Several systems under development (e.g., in Boston, Cleveland, New Britain–Hartford, and Eugene) will have most BRT features.

### 1-3.2.1. Running Ways

Running ways for BRT include mixed traffic lanes, curb bus lanes, and median busways on city streets; reserved lanes on freeways; and bus-only roads and tunnels. Systems normally have a combination of running ways—for example, in North America, curb bus lanes and mixed traffic operations complement busways. Table 1-3 summarizes the principal characteristics of running ways by region. The case study data show that busways dominate North American practice, whereas median arterial busways are widely used in South

**TABLE 1-3 Running way characteristics by region**

TYPE	N. AMERICA	AUSTRALIA	EUROPE	S. AMERICA
Bus Tunnel	Boston Seattle	Brisbane		
Busway (Separate Right- of-Way)	New Britain– Hartford Miami Ottawa Pittsburgh	Adelaide <sup>3</sup> Brisbane Sydney	Runcorn	
Busway in Freeway Median	Charlotte Los Angeles			
Reserved Freeway Lanes	Houston <sup>7</sup> New York City <sup>8</sup> Ottawa			
Median Arterial Busway	Cleveland Eugene <sup>2</sup> Vancouver			Belo Horizonte Bogotá <sup>6</sup> Curitiba <sup>9</sup> Porto Alegre Quito <sup>6</sup> São Paulo <sup>6</sup>
Bus Lanes <sup>1</sup>			Rouen <sup>5</sup> Leeds <sup>4</sup>	

## NOTES:

<sup>1</sup> Bus lanes are found in many cities with busways, freeway lanes, and median arterial busways, (e.g., Boston, Houston, New York City, Ottawa, Pittsburgh, and Vancouver).

<sup>2</sup> Electronically Guided Bus.

<sup>3</sup> O-Bahn Guided Bus.

<sup>4</sup> Optically Guided Bus.

<sup>5</sup> Guided Bus with Queue Bypass.

<sup>6</sup> Optically Guided Bus.

<sup>7</sup> Reversible HOV Lanes.

<sup>8</sup> Contra Flow Bus Lanes.

<sup>9</sup> High-platform Stations with Fare Prepayment.

SOURCE: Levinson et al., 2003.

America. Reversible and contra flow lanes and HOV lanes along freeways are found only in the United States. Bus tunnels, such as those in Brisbane and Seattle and the one under construction in downtown Boston, bring a major feature of rail transit to BRT.

### 1-3.2.2. Stations

The spacing of stations along freeways and busways ranges from 2,000 to 21,000 feet, enabling buses to operate at high speeds. Spacing along arterial streets ranges upward from about 1,000 feet (e.g., Cleveland and Porto Alegre) to over 4,000 feet (e.g., Vancouver and Los Angeles). Most stations are located curbside or on the outside of bus-only roads and arterial median busways. However, the Bogotá system, a section of Quito's Trolebus, and Curitiba's "direct" (express) service have center island platforms and vehicles with left-side doors.

Busways widen to three or four lanes at stations to enable express buses to pass stopped buses. South America's arterial median busways also provide passing lanes. Stations and passing lanes are sometimes offset to minimize the busway envelope.

Most BRT stations have low platforms because many are or will be served by low-floor vehicles. However, Bogotá's TransMilenio, Quito's Trolebus, and Curitiba's all-stop and direct express services provide high platforms; some buses are specially equipped with a large ramp that deploys at stations to allow level passenger boarding and alighting. Each of these systems also has off-vehicle fare collection. Rouen features optically guided Irisbus Civis vehicles that provide precision docking, which minimizes the gap for level boarding and alighting.

Stations provide a wide range of features and amenities depending on locations, climate, type of running way, patronage, and available space. Overhead walks with fences between opposite directions of travel are provided along busways in Brisbane, Ottawa, and Pittsburgh.

### 1-3.2.3. Vehicles

Conventional standard and articulated diesel-powered buses are widely used for BRT operations. There is, however, a trend toward innovation in vehicle design in terms of (1) "clean" vehicles; (2) dual mode (diesel or CNG/electric) operations through tunnels; (3) low-floor buses; (4) more and wider doors; and (5) distinctive, dedicated BRT vehicles. Examples of innovative vehicle designs include the following:

- Los Angeles' low-floor red and white CNG vehicles;
- Boston's planned multidoor, CNG, and dual mode diesel-electric vehicles; and
- Curitiba's double articulated buses with five sets of doors and high-platform loading.

Rouen's Irisbus Civis—a "new design" hybrid diesel-electric articulated vehicle with trainlike features has four doors and a minimum 34-inch-wide aisle end to end. It can be optically guided to precision dock at stations, allowing gap-free boarding and alighting.

### 1-3.2.4. ITSs

Applications of ITS technologies include automatic vehicle location (AVL) systems, passenger information systems, and traffic signal preference at intersections. The Metro Rapid bus routes in Los Angeles can get up to 10% of the cycle length in additional green time when buses arrive late at signalized intersections.

### 1-3.2.5. Service Patterns

Service patterns reflect the markets being served and impact of the types of running ways and vehicles utilized. Many systems provide an "overlay" of express (or limited-stop) service, all-stop (or local service), and "feeder" bus services at selected stations. Service in most systems extends beyond the limits of busways or bus lanes—an important advantage of BRT. However, the Bogotá, Curitiba, and Quito systems operate only within the limits of the special running ways because of door arrangements, platform heights, and/or propulsion systems.

### 1-3.2.6. Performance

The performance of the BRT systems evaluated ranges widely, based on the configuration of each system. For the purposes of this report, performance was measured in terms of passengers carried, travel speeds, and land development changes.

**Ridership.** Measured in terms of boarding, weekday riders reported for systems in North America and Australia range upward from 1,000 in Charlotte to 40,000 or more in Los Angeles, Seattle, Adelaide, and Brisbane. Daily ridership in Ottawa and the South American cities is substantially higher, exceeding 150,000 per day.

Examples of the heavier peak-hour, peak-direction passenger flows at the maximum load points are shown in Table 1-4. These flows equal or exceed the number of LRT passengers carried per hour in most U.S. and Canadian cities and approach rail rapid-transit volumes.

Reported increases in bus riders because of BRT investments reflect expanded service, reduced travel times, improved facility identity, and population growth. Examples of ridership gains include the following:

- 18 to 30% were new riders in Houston;
- Los Angeles had a 26 to 33% gain in riders, one-third of which was new riders;

**TABLE 1-4 Peak-hour, peak-direction passenger flows**

PASSENGER VOLUMES	BRT SYSTEM
Over 20,000 per hour	New Jersey: Approach to Lincoln Tunnel
	Bogotá's TransMilenio
	Porto Alegre
	São Paulo
8,000–20,000 per hour	Belo Horizonte
	Ottawa
	Quito
	Curitiba
	Brisbane

SOURCE: Levinson et al., 2003.

- Vancouver had 8,000 new riders, 20% of whom previously used automobiles, and 5% of whom represented new trips;
- Adelaide had a 76% gain in ridership;
- Brisbane had a 60% gain in ridership; and
- Leeds had a 50% gain in ridership.

**Speeds.** Operating speeds reflect the type of running way, station spacing, and service pattern. Typical speeds are shown in Table 1-5. Speeds on arterial streets generally average less than 20 miles per hour; 14 miles per hour is typical. Speeds on busways or in freeway bus lanes can range up to 50 miles per hour depending on spacing of stops.

**Travel Time Savings.** Reported travel time savings over pre-BRT conditions are illustrated in Table 1-6. Busways on dedicated rights-of-way generally save 2 to 3 minutes per mile compared with pre-BRT conditions. Bus lanes on arterial streets typically save 1 to 2 minutes per mile. The time savings are greatest along bus routes that previously experienced major congestion.

**Land Development Benefits.** Reported land development benefits with full-featured BRT are similar to those experienced along rail transit lines. Ottawa reported about \$675 million (U.S. dollars) in new construction around Ottawa Transitway stations. Pittsburgh reported \$302 million in new and improved development along the East Busway, and property

**TABLE 1-5 Typical operating speeds**

Freeway-Busway	Speeds
Non-Stop	40–50 mph
All-Stop	25–35 mph
<b>Arterial Streets</b>	
Express, Bogotá, Curitiba	19 mph
Metro Rapid bus, Ventura Blvd., Los Angeles	19 mph
Metro Rapid bus, Wilshire Blvd., Los Angeles	14 mph
All-Stop—Median Busways, South America	11–14 mph
Limited Stop—New York City	8–14 mph

SOURCE: Levinson et al., 2003.

**TABLE 1-6 Examples of travel time savings**

BRT System	Reported Travel Time Savings
Busways, Freeway lanes	32–47%
Bus Tunnel—Seattle	33%
Bogotá	32%
Porto Alegre	29%
Los Angeles Metro Rapid bus	23–28%

SOURCE: Levinson et al., 2003.

values near Brisbane's South East Busway stations grew 20% faster than property values in the surrounding area.

**Costs.** Facility development costs reflect the type of construction and its complexity, as well as the year of construction. Reported median costs were \$272 million per mile for bus tunnels (2 systems), \$12.8 million per mile for dedicated busways (12 systems), \$6.6 million per mile for arterial median busways (5 systems), \$4.7 million per mile for guided bus operations (2 systems), and \$1 million per mile for mixed traffic or curb bus lanes (3 systems). Comparisons of BRT and light rail operating costs suggest that BRT can cost the same or less to operate per passenger trip or passenger mile than LRT.

**1-4. IMPLICATIONS AND DIRECTIONS**

Unique circumstances in each urban area influence BRT markets, service patterns, viability, design, and operations. Within this context, several key lessons, implications, and directions emerged from the case studies. Many of these lessons also can apply to rail rapid-transit planning and development.

**BRT system development should be an outgrowth of a planning and project development process that addresses demonstrated needs and problems.** There should be an open and objective process through all phases of BRT development.

**Early and continuous community support from elected leaders and citizens is essential.** Public decision makers and the general community must understand the nature of BRT and its potential benefits. BRT's customer attractiveness, operating flexibility, capacities, and costs should be clearly and objectively identified in alternatives analyses that consider other mobility options as well.

**State, regional, and local agencies should work together in planning, designing, and implementing BRT.** This requires close cooperation of transit service planners, city traffic engineers, state department of transportation (DOT) highway planners, and urban land planners. Metropolitan planning agencies and state DOTs should be major participants.

**Incremental development of BRT will often be desirable.** Incremental development may provide an early opportunity

to demonstrate BRT's potential benefits to riders, decision makers, and the general public, while still enabling system expansion and possible upgrading.

**BRT systems should provide reasonable usage, travel time savings, cost, development benefits, and traffic impacts.** The greater the number and sophistication of the elements constituting the BRT system, the greater the benefits.

**Parking facilities should complement, not undercut, BRT.** Adequate parking is essential at stations along high-speed transitways in outlying areas. It may be desirable to manage downtown parking space for employees, especially where major BRT investments are planned.

**BRT and land use planning in station areas should be integrated as early as possible.** Adelaide, Brisbane, Ottawa, Pittsburgh, and Curitiba have demonstrated that BRT can have land use benefits similar to those resulting from rail transit. Close working relationships with major developers may be necessary in addressing issues of building orientation, building setbacks, and connections to stations.

**BRT should serve demonstrated transit markets.** Urban areas with more than a million residents and a central area employment of at least 75,000 are good candidates for BRT in North American cities. These areas generally have sufficient corridor ridership demands to allow frequent all-day service. BRT works well in physically constrained environments where hills, tunnels, and water crossings result in frequent traffic congestion.

**It is essential to match markets with rights-of-way.** The presence of an exclusive right-of-way, such as along a freeway or railroad corridor, is not always sufficient to ensure effective BRT service. This is especially true when the rights-of-way are removed from major travel origins and destinations and the stations are inaccessible. Ideally, BRT systems should be designed to penetrate major transit markets.

**The key attributes of rail transit should be transferred to BRT, whenever possible.** These attributes include segregated or priority rights-of-way; attractive stations; off-vehicle fare collection; quiet, easily accessible, multidoor vehicles; and clear, frequent, all-day service. A successful BRT project requires more than merely providing a queue bypass, bus lane, or dedicated busway. It requires the entire range of rapid-transit elements and the development of a unique system image and identity. Speed, service reliability, and an all-day span of service are extremely important. Corridors should not be cut merely to reduce costs.

**BRT should be rapid.** This is best achieved by operating on exclusive rights-of-way wherever possible and by maintaining wide spacing between stations.

**Separate rights-of-way can enhance speed, reliability, safety, and identity.** These running ways can be provided as integral parts of new town development or as an access framework in areas that are under development. They also may be provided in denser, established urban areas where right-of-way is available. Bus tunnels may be justifiable where congestion is frequent, bus and passenger volumes are high, and street space is limited.

**The placement, design, and operation of bus lanes and median busways on streets and roads must balance the diverse needs of buses, delivery vehicles, pedestrians, and general traffic flows.** Curb lanes allow curbside boarding and alighting, but they may be difficult to enforce. Median busways provide greater identity and avoid curbside interferences, but they may pose problems with left turns and pedestrian access. Moreover, they generally require streets that are at least 75 feet in width from curb to curb.

**Vehicle design, station design, and fare collection procedures should be well coordinated.** Stations should be accessible by bus, automobile, bicycle, and/or foot. Adequate berthing capacity, passing lanes for express buses (on busways), and amenities for passengers should be provided. Buses should be distinctively designed and delineated. They should provide sufficient passenger capacity, multiple doors, and low floors for easy passenger access. There should also be ample interior circulation space. Off-vehicle fare collection is desirable, at least at major boarding points. Achieving these features calls for changes in operating philosophies and practices. ITS and smart card technology applied at multiple bus doors may facilitate rapid on-board payment without losing revenues.

**Coordinated traffic engineering and transit service planning is essential for BRT system design.** It is especially critical in designing running ways, locating bus stops and turn lanes, applying traffic controls, and establishing traffic signal priorities for BRT.

**BRT service can extend beyond the limits of dedicated running ways where a reliable, relatively high-speed operation can be sustained.** Outlying sections of BRT lines can use HOV or bus lanes or even operate in the general traffic flow.

**BRT services should be keyed to ridership.** The maximum number of buses during peak hour should meet ridership demands and simultaneously minimize bus-bus congestion. Generally, frequent, all-stop, trunk-line service throughout the day should be complemented by an "overlay" of peak-period express services serving specific markets. During off-peak periods, overlay services could operate as feeders (or shuttles) that are turned back at BRT stations.

## 1-5. PROSPECTS

**The case studies demonstrate that BRT does work.** It can reduce journey times, attract new riders, and induce transit-oriented development. It can be more cost-effective and provide greater operating flexibility than rail transit, and it can serve as a cost-effective extension of rail transit lines. Generally, BRT systems can provide sufficient capacity to meet peak-hour travel demands in most U.S. corridors.

**One of the key lessons learned from the case studies is that BRT should be rapid.** Reliably high speeds can be best achieved when a large portion of the service operates on separate rights-of-way.

**Major BRT investment should be reinforced by transit-supportive land development and parking policies.** Because BRT has the potential to influence land use, it is desirable to incorporate considerations for BRT, as with other rapid-transit modes, into land use planning.

It is expected that more cities will examine and implement BRT systems. There will be a growing number of fully inte-

grated systems and even more examples of selected BRT elements being implemented. These efforts will lead to substantial improvements in urban transit access, mobility, and quality of life.

## 1-6. CHAPTER 1 REFERENCES

- “BRT—Bus Rapid Transit—Why More Communities Are Choosing Bus Rapid Transit” (Brochure). Transportation Research Board, National Research Council, Washington, DC (2001).
- Levinson, H. S., S. Zimmerman, J. Clinger, S. Rutherford, J. Cracknell, and R. Soberman. “Case Studies in Bus Rapid Transit—Draft Report” (TCRP Project A-23). Transportation Research Board of the National Academies, Washington, DC (December 2002).
- Levinson, H., S. Zimmerman, J. Clinger, S. Rutherford, R. L. Smith, J. Cracknell, and R. Soberman. *TCRP Report 90: Bus Rapid Transit, Volume 1: Case Studies in Bus Rapid Transit*. Transportation Research Board of the National Academies, Washington, DC (2003).
- Thomas, E. Paper presentation at the Institute of Transportation Engineers Annual Meeting, Chicago, IL (August 2001).
-

## CHAPTER 2

# PLANNING CONSIDERATIONS

This chapter sets forth the planning considerations that underlie BRT development. It gives guidelines for a basic planning process, indicates when (and where) BRT should be considered, identifies some planning principles and objectives, and illustrates the two basic types of systems.

### 2-1. SYSTEM DEVELOPMENT PROCESS

Planning for BRT should essentially be the same as planning for any rapid-transit investment. BRT system development should be an outgrowth of a planning and project development process that stresses problem solving and addresses demonstrated needs and issues, rather than solution advocacy. The implementation of federally funded BRT within the United States begins with a multi-modal planning process that focuses on alternative ways to meet mobility needs. When studies indicate that some type of major transit *capital* investment may be required in a given corridor (e.g., a busway), an analysis of potential alternatives to meet these needs is usually undertaken. However, where *low-cost, short-term operational* strategies are involved (e.g., curbed bus lanes and skip-stop operation), these may be implemented by the transit operator in conjunction with highway and street traffic agencies with little detailed alternatives analysis (*Issues in Bus Rapid Transit*, 1998).

#### 2-1.1. Issues in the BRT Planning Process

A key issue, unique to BRT planning, is dealing with modal biases in the system planning process and the perceived greater desirability of rail transit. Other issues are similar to planning for any rapid-transit mode and include finding suitable corridors for BRT, obtaining street space for buses and sidewalk space for stations, achieving effective enforcement, and overcoming fragmentation of responsibilities and conservative agency attitudes. All should be addressed in the planning process. Brief discussions of these issues in the system planning process follow:

1. *No prejudgment of modal options.* Alternatives analyses and other transit planning studies may be engaged with a predisposition toward a mode and technology, even if these analyses are not supported by ridership or other factors. As a result, these analyses may not satisfactorily

address the full range of system types and technologies available, including BRT.

2. *No biases in cost estimates and ridership forecasts.* There has been a tendency in some alternatives analyses to *overestimate* ridership and *underestimate* the capital, operating, and maintenance costs of major transit investments. This tendency may result in more capital-intensive projects than can actually be justified.
3. *Not prejudging the perceived desirability of rail transit.* There is frequently the perception that rail transit is more attractive than bus transit and that “world-class cities” need rail transit. These attitudes often derive from the following:
  - Bus service is generally perceived as having lower quality and less ridership potential than rail.
  - Buses are perceived as less environmentally friendly than rail systems.
  - BRT is perceived as not having the same degree of permanence associated with steel rails and other fixed guideways. This can result in less impact on land development decisions and, potentially, lead to political and community pressure to convert underutilized BRT services to normal road use. For example, one concern that has been expressed by some environmental groups is that busways are merely a way of expanding the road network without making long-term investments in transit infrastructure.
4. *Finding suitable corridors for BRT lines and matching markets with rights-of-way.* Often, rights-of-way—especially for dedicated busways or bus lanes—are not practical in areas of high development densities and ridership demands. In addition, rights-of-way that are available (e.g., on abandoned rail lines or within freeway medians) may not be able to capture a key segment of the potential market. Further, they may not allow convenient and safe pedestrian access. Often, the wide streets necessary for busways that are located in the center of roadways are not available in dense areas.
5. *Balancing the use of street space.* BRT, like LRT, will preempt street space. Buses will compete with general traffic flow, curbed parking and access, and sometimes pedestrians for a limited amount of street space. This

may require demonstrating that sufficient capacity exists in the corridor to accommodate one or more lanes for BRT vehicles, without decreasing capacity for peak-hour vehicular traffic. Providing effective *downtown* distribution for buses also may pose problems. Bus-only lanes may be difficult to justify and implement when there are few buses.

6. *Achieving effective enforcement.* Enforcement of parking and loading restrictions along many bus routes and bus lanes is ineffective. Merchant willingness to remove curb parking is often difficult to achieve.
7. *Addressing institutional fragmentation of responsibilities.* Developing BRT can be inhibited by the many agencies that may be involved: city, county, and state transportation departments (often with a focus on roadways); the transit agency; the parking authority; and metropolitan and local planning organizations. Perspectives and priorities may vary, and responsibilities may differ or overlap. State DOTs, for example, may favor HOV lanes or may be unwilling to adopt roadway designs that better accommodate public transport with pedestrian access/egress.
8. *Conservative agency attitudes.* Transit agencies may be primarily concerned with balancing operating costs and revenues. They may perceive BRT as a simple extension of their bus system that does not require special attention to vehicle design, fare collection, or other key rapid-transit features. Transit agencies in areas that have rail transit lines may be accustomed to placing a high priority on rail facilities for high-capacity passenger movements, but they may not be used to applying a similar “quality” philosophy to their bus service. Traffic engineers may also be hesitant to allocate street space for buses away from general purpose traffic or to evaluate options in terms of person travel rather than vehicle movements.

Changing these perceptions and addressing these preconceptions requires clearly identifying the many benefits of BRT and ensuring the provision of high-quality BRT service. The challenge is to show that BRT can be not only cost-effective but also environmentally friendly, efficient in influencing urban land use, and quickly developed. Many BRT systems have achieved significant ridership, high capacities and performance, reasonable operating and maintenance costs, significant travel time savings, and substantial transit-oriented development.

### 2-1.2. Community and Agency Support and Coordination

Early and continuous community and decision-maker involvement and support are essential through an open planning process. Public dialogue should be maintained at each major step in the planning process. Community and advo-

cacy concerns should be recognized and responded to at each major milestone.

Because successful BRT implementation generally requires participation of transit operators and highway agencies, all prospective actors should be a formal part of the planning effort. Participants also may include representatives of private sector transit operators as well as the police department officials that may be responsible for exclusive transit facility enforcement, safety, and security.

State, regional, and local cooperation is important in planning, developing, and implementing BRT. Transit planners, traffic engineers, and urban planners must work together. In the United States, metropolitan planning agencies and state DOTs should be major participants.

### 2-1.3. Modal Considerations

Planning should be approached from the perspectives of the communities (and agencies) involved, and it should be presented in their terms. There should be a clear justification of any BRT proposal in terms of costs and benefits. The planning of BRT systems, like other rapid-transit systems, should strike a balance between usage, travel time savings, and development benefits. BRT alternatives should be assessed in terms of overall transportation system mobility needs, environmental effects, and land development benefits.

Decision makers and the general community must clearly understand the nature of BRT and its potential benefits during planning in order to avoid any biases and misconceptions. BRT’s potential performance, customer and developer attractiveness, operating flexibility, capacities, and costs should be clearly identified through an alternatives analysis that objectively considers various modal options.

The principal advantages of BRT relative to rail systems include the following:

- The ability to alter design standards as volumes increase over various segments of a route in accordance with capacity needs (i.e., much greater “staging” or incremental development capability);
- Relatively low capital costs for infrastructure (i.e., no need for track, electrification, and other fixed plant);
- The potential for higher and more flexible types and frequencies of service over different route segments (i.e., capacity need not be constant over the entire route);
- The flexibility to combine feeder (i.e., collector and distribution on local streets) and line-haul services without the need for a physical transfer between vehicles;
- Opportunities to extend service into low-density areas without the need for additional dedicated running ways;
- The capability of being used by a variety of vehicle sizes and types;
- The ability to accommodate a diversity of operating organizations (e.g., public operators, school buses, and private carriers);



- Simpler procurement practices for both construction and vehicles;
- Shorter implementation periods;
- The ability to start construction on key sections first, such as segments that provide congestion relief or are the easiest to build, and still provide integrated service for an entire corridor;
- No requirements for additional organizational structures such as those usually associated with building and operating rail systems;
- Greater flexibility for off-line stations that can increase capacity;
- The ability to use existing roads and streets when an incident occurs that would otherwise cause major disruption in service;
- A variety of competitive vehicle suppliers and less need for conformity in vehicle procurement; and
- Less expensive vehicles, even when accounting for capacity and service life differences.

The main technical advantage of rail transit is its ability to run high-capacity trains in high-volume corridors. This results in the following:

- Potentially less labor-intensive operation, depending on passenger volumes;
- Greater potential capacity;
- Better levels of service at higher volumes;
- A more positive image on the part of developers and customers; and
- Less expensive vehicles, even accounting for capacity and service life differences

#### 2-1.4. Steps in the Planning Process for BRT

BRT planning in the United States should be consistent with the New Starts procedures set forth by the FTA, which are discussed in more detail in Chapter 9. Environmental impact assessments and statements may be required when major construction is required.

Planning BRT calls for a realistic assessment of the demands, costs, benefits, and impacts of a full range of options. The objective is to develop a coordinated set of actions that achieve attractive and reliable BRT services, serve demonstrated demands, provide reserve capacity for the future, attract automobile drivers, relate to long-range land use and development plans, and have reasonable costs.

Key factors include (1) the intensity and growth prospects and patterns of the urbanized area; (2) the existing and potential future demand for public transportation; (3) expansion of the urbanized area; (4) street width continuity, capacity, and congestion; (5) opportunities for off-street running ways; (6) bus operating speeds and reliability; (7) locations of major employment centers and residential developments in relation to potential BRT routes; (8) community attitudes; and

(9) community resources. Community willingness to support public transportation, foster transit-oriented development, and enforce bus lanes is essential (Fuhs, 1990).

##### 2-1.4.1. Identify Needs and Establish Conceptual Viability

The conceptual viability of various options, in terms of needs, usage, practicality, benefits, land uses served, and ability for the system to be built, should be established. This involves addressing several key questions:

- What are the existing numbers of buses and bus passengers using the corridor during daily and peak periods? What are the projected future transit needs? Are the numbers sufficient to warrant BRT and to establish bus lanes and/or build busways?
- What are the general traffic flows in the corridor?
- What are bus and automobile travel speeds, and where are the major points of congestion?
- What time savings are likely from bus service operations and running way improvements? To what extent would person delay be reduced?
- What are the design and operating features of roadways in the study corridor?

Opportunities for developing BRT should be explored, as should potential constraints on development. This calls for identifying (1) roads and rights-of-way that could be used for the BRT system, (2) ways to accommodate buses through the city center, (3) needed changes in the use of road space and traffic controls, (4) bus service operating strategies, (5) whether the initial concepts are viable, and (6) any potentially fatal flaws.

##### 2-1.4.2. Develop and Analyze Alternatives

Various combinations of facility, service, and amenity improvements should be analyzed in terms of operating features, travel time savings, environmental and land development impacts, and costs. The effectiveness of specific options requires consideration of multiple criteria (Fuhs, 1990). These criteria are the following:

- *Mobility*—access to employment, services, and facilities; bus travel time savings; impacts on traffic operation; increases in bus ridership; and operational workability.
- *Environmental Impacts*—reduced use of private vehicles and attendant air pollution and impacts on water resources and wetlands, parks and open spaces, and historical and cultural resources.
- *Land Use*—compatibility with local land use policies and goals and contribution to transit-oriented land use and economic development.

- *Costs*—total project cost (capital and operating), measures of cost-effectiveness (e.g., operating and capital cost per passenger trip or passenger mile for each alternative), and funding availability.
- *Ridership*—ridership estimates and service plans should be developed for (1) the opening year, (2) when ridership has matured (e.g., 5-year period), and (3) a 20-year horizon. Some travel demand model development and validation may be required in developing long-range ridership forecasts. Forecasts should be checked for reasonability. *TCRP Web Document 12: Traveler Response to Transportation System Changes, Interim Handbook* provides guidance on estimating changes in ridership resulting from BRT improvements (Pratt et al., 2000).

Each option should also be assessed in terms of (1) how it reflects regional planning objectives such as CBD and central area mode shares, (2) how it relates to and can help shape future growth and contribute to redevelopment, (3) how convenient and easy it is to use, (4) how well it provides a strong sense of permanence and identity and (5) what levels of enforcement are required.

If BRT is adopted as the preferred solution, proposed capital improvements should be incorporated into the financially constrained regional transportation plan and developed by the metropolitan planning organization in cooperation with local transportation agencies. More detailed engineering and completion of required environmental documentation is needed before federal funding becomes available and construction can begin.

#### 2-1.4.3. Prepare Recommended Plans

The recommended plans should clearly describe and detail running way, station, vehicle, fare collection, and service elements. Project plans should address the following:

- Vehicle requirements;
- Horizontal and vertical alignments;
- Geometric design features of running ways such as cross sections, points of ingress/egress, and CBD distribution;
- Station locations and typical designs that show platforms, shelters and structures, passenger amenities, pedestrian access, bus transfer arrangements, and parking;
- Fare collection approach, equipment, and facilities;
- Traffic controls and ITS applications;
- Bus operating plans including routing, service span, types, and frequencies;
- Provisions for maintenance and enforcement;
- A staging plan;
- Refined cost estimates; and
- Opportunities for transit-oriented development at stations.

The resulting BRT plan should be developed as an integrated system that adapts the various attributes of rail transit,

focuses on major markets, emphasizes speed and reliability, takes advantage of incremental development and established complementary transit-first policies, and is designed to influence transit-oriented development. The BRT plan should improve speed, reliability, and identity. The elimination or reduction of critical system elements to cut costs should be avoided.

## 2-2. DESIRABLE CONDITIONS FOR BRT

Rapid transit in general and BRT in particular work best in urban areas characterized by (1) high employment and population density, (2) an intensively developed downtown area with limited street capacity and high all-day parking costs, (3) a long-term reliance on public transport, (4) highway capacity limitations on approaches to the city center, and (5) major physical barriers that limit road access to the CBD and channel bus flows.

It is suggested that the following three conditions should be in place when BRT is being considered: (1) the proposed location is a large city with a strong CBD, an urbanized area, or an activity center with dense patterns that facilitate transit use; (2) there are current total passenger flows that might support high service frequencies that are characteristic of rapid transit, and (3) there is a sufficient “presence” of buses where bus lanes or busways are being considered.

### 2-2.1. City Size and Downtown Intensity

The size of urban areas, the concentration of population and activities in key corridors, and the strength of the CBD have important bearing on the transit market in general and BRT in particular. The case studies show that most BRT systems are found in urbanized areas of more than 750,000 people and (in the United States and Canada) areas with downtown employment that exceeds 75,000. These values are remarkably consistent with the “pre-conditions” for rail and bus transit developed for North American cities in previous studies (see Table 2-1).

There may, of course, be special situations in smaller urbanized areas that make BRT desirable. Factors include major physical and topographic restraints; large employment and activity concentrations such as universities, hospitals, and edge city centers; ready availability of relatively inexpensive rights-of-way; new town or major sub-area developments; and rapid urban growth. However, in general, BRT is essentially a large-city system in the United States and Canada.

### 2-2.2. Frequent All-Day Service

High service frequencies are essential to make BRT attract riders. The minimum desired service frequencies for a BRT line are 8 to 10 minutes during peak periods and 12 to 15 minutes during off-peak periods, with a span of services through-

**TABLE 2-1 General conditions conducive to urban rapid transit development—  
design year**

PRIMARY DETERMINANTS	RAIL	RAIL OR BUS	BUS (MINIMUM)
Urban area population	2,000,000	1,000,000	750,000
Central city population <sup>1</sup>	700,000	500,000	400,000
Central city population <sup>1</sup> density, in people per square mile	14,000	10,000	5,000
High-density corridor development	Extensive and clearly defined	Limited but defined	Limited but defined
CBD Function	Regional	Regional or sub- regional	Regional or sub- regional
CBD floor space, in square feet	50,000,000	25,000,000	20,000,000
CBD employment	100,000	70,000	50,000
Daily CBD destinations, per square mile	300,000	150,000	100,000
Daily CBD destinations per corridor	70,000	40,000	30,000
Peak-hour cordon person movements leaving the CBD (four quadrants)	75,000–100,000	50,000–70,000	35,000

<sup>1</sup> “Effective Central City”—central city and contiguously developed areas of comparable population density.  
SOURCE: *Center City Transportation Project: Urban Transportation Concepts*, 1970.

out the day (at least 16 hours). These service frequencies translate into a daily ridership of at least 5,000. When BRT operates on the same street as local service, the combined daily ridership should be 10,000 or more. When routes converge, overlap service should operate every 2 to 4 minutes during the peak period and every 5 to 6 minutes at midday.

### 2-2.3. Bus Presence

Buses should denote a clear presence when bus lanes or busways are provided. Ideally, there should be at least one bus per traffic signal cycle using curb bus lanes to minimize violations; this translates into 40 to 60 buses per hour depending on the cycle length. Similarly, bus-only roads should serve an adequate number of buses to demonstrate utilization of the facilities (e.g., a bus is always visible at all points along the facility).

## 2-3. OBJECTIVES AND PRINCIPLES

The following general principles should guide BRT planning and development.

1. *BRT should be developed as a permanently integrated system of facilities, services, and amenities.* It should improve bus speed, reliability, and identity.
2. *The BRT system should adopt the key attributes of rail transit to the maximum extent possible.* These attributes include segregated or priority running ways; attractive stations (with off-vehicle fare collection wherever practical); quiet, easily accessible, environmentally friendly, low-floor, multidoor vehicles; ITS technologies; and fast, frequent service.
3. *BRT should be complemented by appropriate “Transit First” policies.* These include transit-oriented land development, complementary downtown parking policies and adequate park-and-ride facilities at outlying stations, and reservation (or acquisition) of rights-of-way in developing or redeveloping areas. Similarly, BRT should be used to stimulate transit-oriented land use patterns.
4. *BRT lines should focus on major travel markets in which ridership and benefits can be maximized.* Radial lines should link the city center with outlying population concentrations and provide extensive coverage of downtown employment. Cross-town lines sometimes may be appropriate when they serve “edge cities,” large university campuses, major medical centers, or other large attractors.
5. *BRT should be rapid.* Service should operate on separate rights-of-way wherever possible and use wide, free-flowing streets where dedicated rights-of-way are unfeasible or inaccessible to key transit markets. Street running should be expedited by means of bus priority treatment and transit-sensitive traffic controls, and station stops should be limited (e.g., from ¼ mile in CBDs to no less than ½ mile in suburban areas).
6. *BRT systems should be capable of early action and amenable to stage (incremental) development.* Staging may involve extending routes and running ways, providing BRT in additional corridors, replacing street running with exclusive running ways (such as a downtown bus tunnel), and/or even ultimately converting busways to rail transit if warranted by ridership demands.
7. *BRT systems should be reasonable in terms of benefits, costs, and impacts.* The system should maximize

benefits to the community, the urban travelers (especially the transit rider), and the transit agency. Investments should be balanced with present and likely future ridership. The system should be designed to increase *transport* capacities in heavily traveled corridors, reduce travel times for riders, and minimize total person delay in the corridors served. A basic goal should be to maximize person flow with the minimum net total person delay over the long run. Implicit in achieving this objective is the efficient allocation of corridor road space.

8. *Streets and corridors with existing long, heavily traveled bus routes are likely candidates for BRT. If at least one existing local bus route does not have at least 6,000 to 8,000 daily trips on it, BRT may not be justified in the short term.* Often, BRT development will involve restructuring existing bus routes to provide sufficient service frequency along at least one BRT route.
9. *System design and operations should enhance the presence, permanence, and identity of the facilities and services.* It must be *more* than merely operating express service along a bus lane or busway.
10. *Each urban area has its own specific needs, opportunities, and constraints that must be recognized.* Thus, BRT systems must be carefully customized in applying the various concepts and in obtaining public support and translating plans into operating systems.
11. *BRT should have a consistent, appealing image.* BRT vehicles, stations, and marketing materials should convey the image of BRT as a rapid, easy-to-use service.

#### 2-4. SYSTEM CONCEPTS

BRT system configurations should reflect the travel needs, opportunities, and geography of each urban area. System configurations may range from a single route to an integrated system of routes. They may provide both line-haul and local collection-distribution services. System configurations can link the city center with outlying areas or serve as extensions to rail transit lines. In each case, the BRT service should be carefully coordinated with the available running ways and the nature of transit markets.

Illustrative examples of these system types are shown in Figures 2-1 and 2-2. The BRT routes operate limited stop (or express) over most of the route—on busways, bus lanes, or in mixed traffic with signal priorities. Buses then make all stops along the outer portions of the route, where generally they would operate in mixed traffic on arterial and/or collector streets.

Diagram 1 of Figure 2-1 shows the simplest system concept, a single radial route that links the city center with outlying areas along a single arterial with simple, all-stop service. As shown in diagram 2 of Figure 2-1, BRT service can serve as an extension of a rail rapid-transit line. (Examples of this kind of service include the South Miami-Dade Busway and the Ventura Metro Rapid line in Los Angeles.) Diagram 3 of Figure 2-1 and Figure 2-2 show that the BRT line can provide direct service to various off-guideway areas (generally located along the outer perimeters of the line) as long as the respective routes can meet minimum service criteria. As shown in diagram 4 of Figure 2-1, a *system* of BRT routes can operate over a series of busways or bus lanes, thereby providing extensive coverage of the urban area. Finally, Diagram 5 of Figure 2-1 shows that a “commuter express” BRT service can be provided using bus-only (or high-occupancy) lanes along freeways. The service would operate nonstop from park-and-ride lots over the express lanes to the city center. Downtown distribution would be by bus lanes on city streets (as in Houston) or by terminals (as in New York City), with all-day, all-stop service also provided.

#### 2-5. CHAPTER 2 REFERENCES

- Fuhs, C. A. *High-Occupancy Vehicle Facilities: A Planning, Design, and Operation Manual*. Parsons Brinckerhoff Quade & Douglas, Inc., New York, NY (1990).
- Issues in Bus Rapid Transit*. Federal Transit Administration, Washington DC (1998).
- Pratt, R. H., Texas Transportation Institute, Cambridge Systematics, Inc., Parsons Brinckerhoff Quade & Douglas, Inc., S. G. Associates, Inc., and McCollum Management Consulting, Inc. *TCRP Web Document 12: Traveler Response to Transportation System Changes, Interim Handbook*. Transportation Research Board, National Research Council, Washington, DC (March 2000).

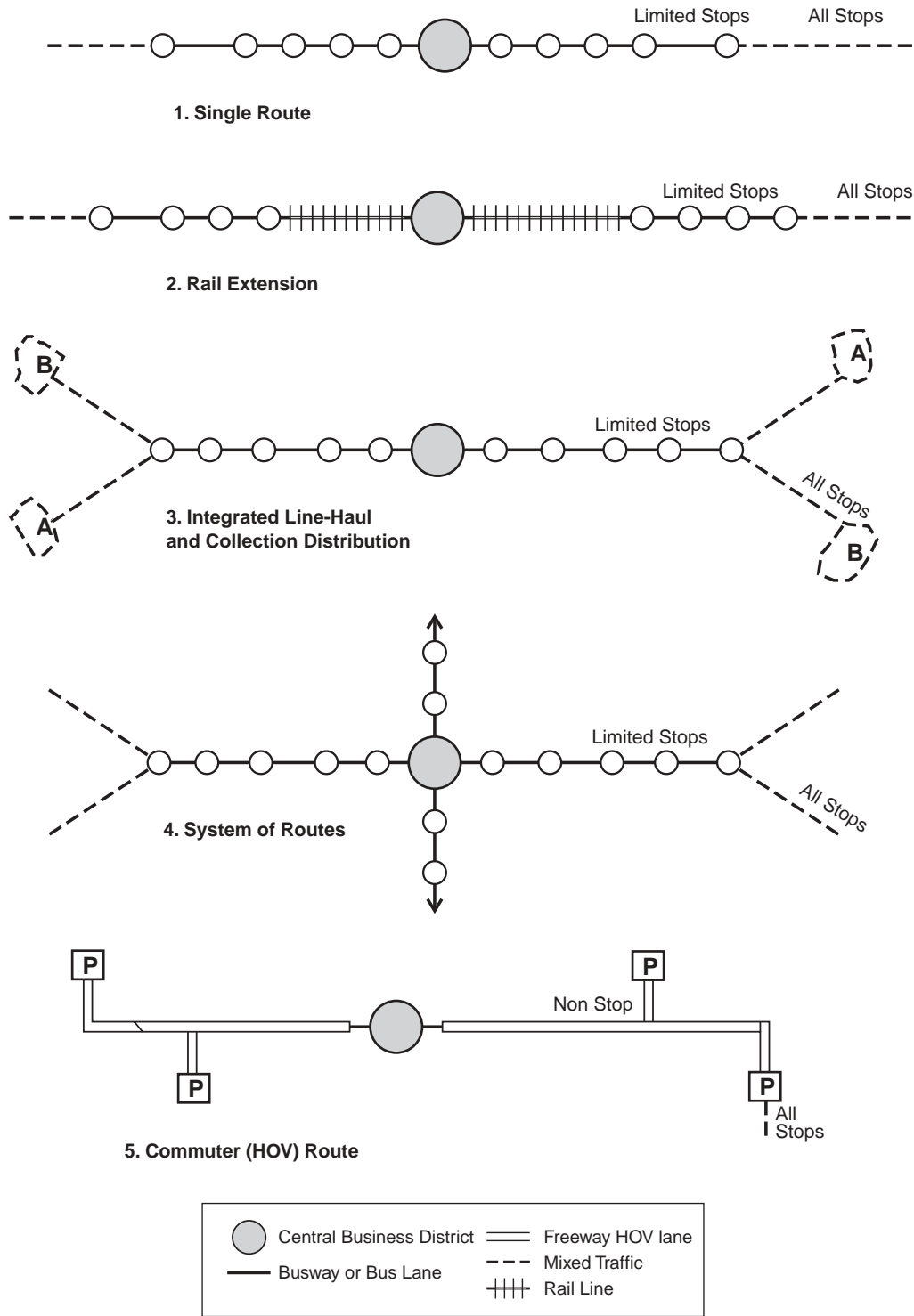


Figure 2-1. BRT routes.

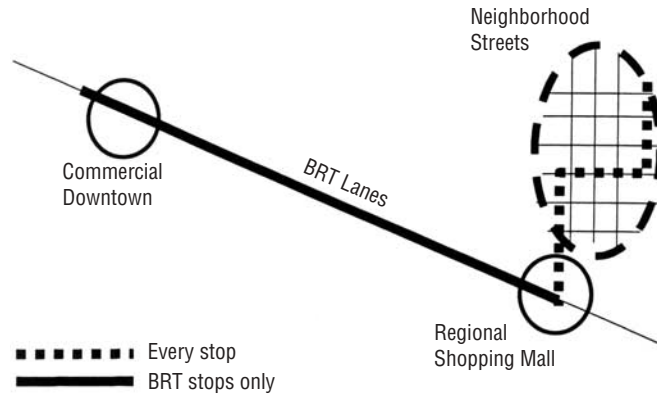


Figure 2-2. Typical BRT route.

---

## CHAPTER 3

# RUNNING WAYS

Running ways are a key element of BRT systems, around which planning and design of the other components revolve (see Figure 3-1). Running ways should allow rapid and reliable movement of buses with minimum traffic interference and provide a clear sense of presence and permanence. The basic goal of a running way is to give BRT an operating environment where buses are free from delays caused by other vehicles and by certain regulations and to provide transit riders with better, more reliable service. This chapter gives general design considerations and specific planning and design guidelines for principal types of running ways. Additional planning and design guidelines can be found in various AASHTO, NCHRP, TCRP, and U.S. DOT publications (*Bus Rapid Transit Options*, 1975; Fitzpatrick et al., 2001; *Guide*, 2001; Levinson et al., 1975; Parsons Brinckerhoff Quade & Douglas, 2002; Texas Transportation Institute et al., 1998).

### 3-1. GENERAL CONSIDERATIONS

General considerations include the following: (1) establishing a BRT running way classification system, (2) defining planning guidelines, (3) identifying desired facility performance, and (4) establishing key design parameters.

#### 3-1.1. Classification Systems

The types of running ways for BRT service range from mixed traffic operation to fully grade-separated busways. They may be classified according to the degree of access control (traffic separation) or by type of facility. A suggested classification scheme by extent of access control is shown in Table 3-1. This system is similar conceptually to those used for highways and rail transit lines. The five classes range from full control of access such as grade-separated busways (Type I) to operation in mixed traffic (Type V). Table 3-2, in turn, groups running ways by busways, freeways, and arterial streets; identifies the specific facilities associated with each; and gives illustrative examples.

#### 3-1.2. General Guidelines

The following guidelines should underlie running way location and design:

1. *Running ways should serve three basic service components—CBD distribution, line haul, and neighborhood collection—in a coherent manner.* Generally, a variety of running way types will be used for each component and be customized to specific needs. Busways or bus lanes will normally provide the line-haul service; CBD distribution may be provided in on-street bus lanes and off-street in bus tunnels, as well as on bus malls or through off-street terminals. Residential distribution may be via bus lanes or in mixed traffic. A dedicated BRT corridor may consist of a number of segments, each with a different running way treatment. Examples of combinations of BRT running ways are shown in Figures 3-2, 3-3, and 3-4:
  - Figure 3-2 shows a basic BRT route that includes operations in mixed traffic flow, dual curb bus lanes, and a park-and-ride lot at the end of the line.
  - Figure 3-3 shows a comprehensive BRT system that includes running ways along freeways, arterial streets, and in separate rights-of-way. It also includes a short downtown bus tunnel that gives busways a traffic-free route through the city center.
  - Figure 3-4 shows how various BRT running ways can be coordinated and staged in the central area of a large city. The goal is to provide through routes that use bus lanes and bus streets, initially, and to incorporate a bus tunnel later, when demand and service levels warrant it.
2. *Running ways should serve major travel markets, and they should penetrate these markets whenever possible.*
3. *Running ways generally should be radial, connecting the city center with outlying residential and commercial areas.* Cross-town running ways may be appropriate in large cities where they connect multiple trip attractors and residential concentrations and have frequent interchanging bus lines. Alignments should be direct, and the number of turns should be minimized.
4. *BRT is best achieved by providing exclusive grade-separated rights-of-way to serve major markets.* Such rights-of-way, however, may be difficult to obtain, costly to develop, and not always located in areas of the best ridership potential. Therefore, street running

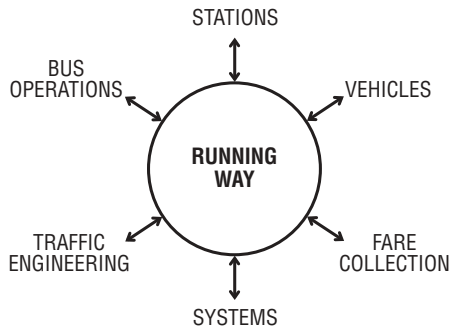


Figure 3-1. The central role of running ways.

ways or exclusive running ways with at-grade intersections may be essential.

5. *Effective downtown passenger distribution facilities are essential in providing direct BRT service to downtown trip origins and destinations.* Downtown distribution should maintain service dependability, minimize time losses resulting from general traffic delays, and provide efficient pedestrian access and egress.
6. *BRT running ways should follow streets that are relatively free flowing wherever possible.* Speed and reliability should be enhanced by transit-sensitive traffic engineering, provision of bus-only lanes, and, in some cases, major street improvements.
7. *Special running ways (busways, bus lanes, and queue bypasses) should be provided.* This should happen when there is (1) extensive street congestion, (2) a sufficient number of buses, (3) suitable street geometry, and (4) community willingness to support public transport, reallocate road space as needed, and enforce regulations.
8. *Preferential treatments for buses may be provided around specific bottlenecks or along an entire route.* Queue bypasses are very effective on approaches to water crossings, at major intersections, or at other traffic bottlenecks with extensive peak-hour congestion.

TABLE 3-1 Running ways classified by extent of access control

Class	Access Control	Facility Type
I	Uninterrupted Flow—Full Control of Access	Bus Tunnel Grade-Separated Busway Reserved Freeway Lanes
II	Partial Control of Access	At-Grade Busway
III	Physically Separated Lanes Within Street Rights-of-Way	Arterial Median Busway, Bus Streets
IV	Exclusive / Semi-Exclusive Lanes	Concurrent and Contra Flow Bus Lanes
V	Mixed Traffic Operations	

Treatments that extend longer distances along BRT routes are desirable.

9. *Running ways should maximize the person flow along a roadway with minimum net total person delay over time.* There should be a net overall savings for all modes in terms of travel time per person. Where road space is allocated to BRT, the person minutes saved should be more than the person minutes lost by people in automobiles. The number of persons traveling per hour in BRT should exceed the number of persons traveling per hour in any of the adjacent general purpose lanes within a 3- to 5-year period after the lane is placed in service.
10. *An exclusive bus lane should carry significantly more people than an adjoining general traffic lane used during the peak travel periods.* The number of bus riders in an exclusive bus lane should exceed the number of automobile occupants using adjacent lanes.
11. *Buses should be able to enter and leave running ways safely and conveniently.* Conflicts with other traffic should be avoided and, when necessary, carefully controlled. This is especially important in developing median and contra flow lanes and busways along arterial streets and within freeway corridors. There should be suitable provisions for passing stopped or disabled buses.
12. *Running ways should provide a strong sense of identity for BRT.* This is especially important when buses operate in bus lanes or in arterial median busways. Using special colors in paving the lanes (e.g., green, yellow, or red) or using specialized materials that differentiate the bus lanes from general traffic lanes is desirable.
13. *Adequate signing, markings, and traffic signal controls are essential.* They are especially important at entry and exit points of arterial contra flow bus lanes and median busways, bus-only streets, busways, and reserved freeway lanes.
14. *Bus lanes and queue bypasses may be provided along both one-way and two-way streets.* Concurrent flow bus lanes should generally allow at least two adjacent general traffic lanes in the same directions of travel. Contra flow lanes should allow at least two traffic lanes in the opposite direction of travel. Median arterial busways should allow at least one travel lane and one parking lane in each direction. In restrictive situations, there should be at least one through and one left-turn lane each way on two-way streets.
15. *Running way designs should be consistent with established national, state, and local standards.* Although subject to unique local roadway conditions and demand, generally, the stops and stations should be accessible for all likely users and should permit safe bus, traffic, and pedestrian movement.
16. *Running way designs may allow possible future conversion to rail transit without disrupting BRT operations.* Service during the construction period is desirable for median arterial busways, busways on separate



**TABLE 3-2 Examples of various types of running ways**

Facility Type	Access Class	Examples
<b>Busways</b>		
Bus Tunnel	1	Boston, Seattle
Grade-Separated Runway	1	Ottawa, Pittsburgh
At-Grade Busway	2	Miami, Hartford
<b>Freeway Lanes</b>		
Concurrent Flow Lanes	1	Ottawa
Contra Flow Lanes	1	New Jersey Approach to Lincoln Tunnel
Bus-Only or Priority Ramps	1	Los Angeles
<b>Arterial Streets</b>		
Median Arterial Busway	3	Curitiba, Vancouver
Curb Bus Lanes	4	Rouen, Vancouver
Dual Curb Lanes	4	Madison Avenue, New York City <sup>1</sup>
Interior Bus Lane	4	Boston
Median Bus Lane	4	Cleveland
Contra Flow Bus Lane	4	Los Angeles, Pittsburgh
Bus-Only Street	4	Portland <sup>1</sup>
Mixed Traffic Flow	5	Los Angeles
Queue Bypass	5	Leeds, Vancouver

<sup>1</sup>Regular bus operations.

rights-of-way, and busways within freeway envelopes, with special attention paid to width-constrained areas and stations.

- 17. *Running ways can be shared by BRT and LRT when they are designed to accommodate both transit types in terms of cross section, curves, grades, and vertical clearance. Stations should be able to serve both kinds of vehicles, speeds should be less than 35 miles per hour, and the two services should not conflict with one another.*

**3-1.3. Performance, Costs, and Capacities**

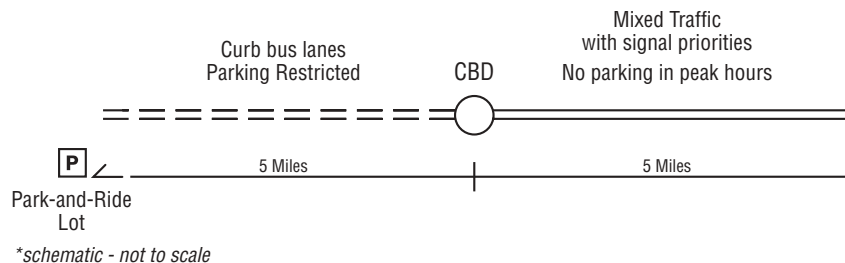
The performance and costs of BRT are related closely to whether the running way is located on city streets or on separate (usually grade-separated) rights-of-way. As shown in

Table 3-3, off-street busways generally provide twice the speed of on-street operations, but they cost more than twice as much. Operations on reserved freeway lanes can provide high speeds at modest costs, but they may make intermediate stations difficult and lose the “identity” associated with other types of running ways.

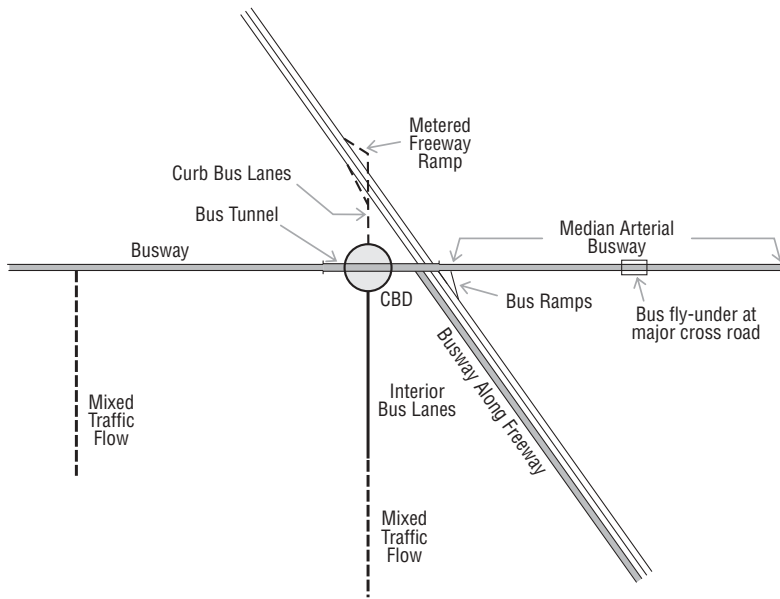
*3-1.3.1. Travel Time Savings*

Bus lanes and busways reduce travel times in general about 1.5 to 2 minutes per mile. Actual time savings are greatest when the previous speeds were the slowest (Figure 3-5).

Bus delays are normally associated with passenger stops, traffic signal delays, and traffic congestion. Figure 3-6 illustrates the use of bus lanes to reduce bus delays. Further

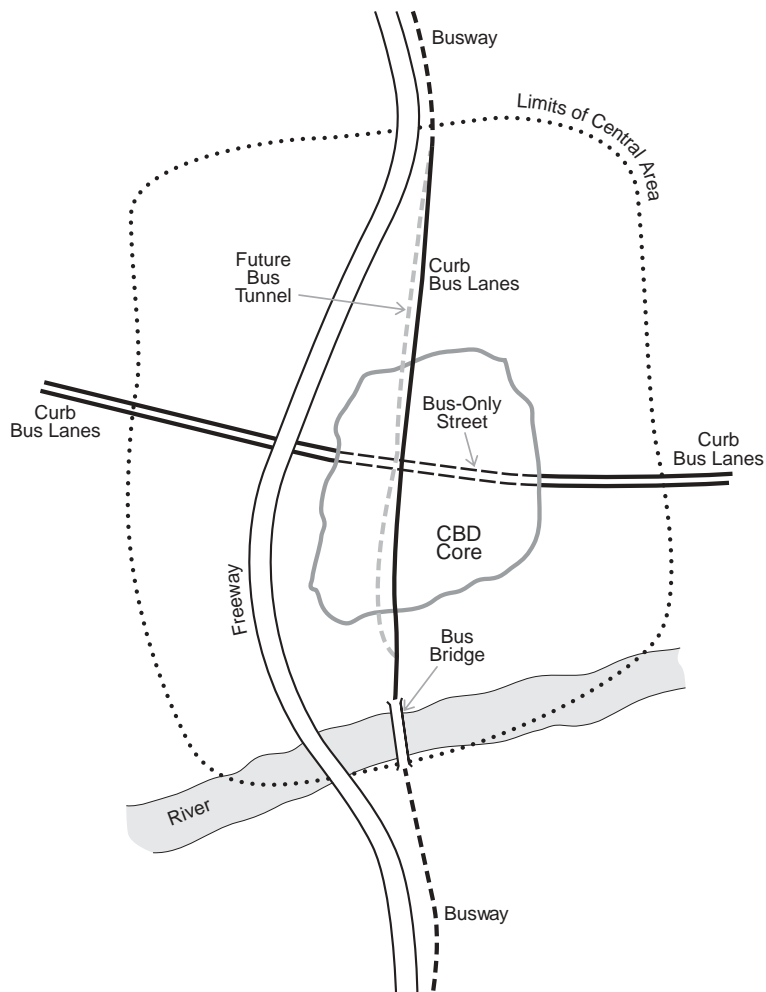


*Figure 3-2. Illustrative BRT running ways using curb bus lanes and mixed flow.*



\*schematic - not to scale

Figure 3-3. Illustrative BRT running ways in a major metropolitan area.



\*schematic - not to scale

Figure 3-4. Illustrative coordination of BRT running ways in a downtown area.

**TABLE 3-3 Running way costs and speeds**

Item	Busway (Grade-Separated)	Arterial Street Median Busway/Bus Lanes
Typical Construction Costs (Millions per mile)	\$6–20	\$1–10
Typical Speeds (Miles per hour)	25–40	12–20

SOURCE: Adapted from Levinson et al., 2003.

time savings would result if passenger boarding and alighting times are reduced (e.g., through use of low floors, multiple wide doors, and off-board fare collection), and traffic signal priorities are introduced.

**3-1.3.2. Capacities**

The number of buses and passengers that can be carried along a BRT route depends on the type of running way, the design of stations and stops, the size, height, and arrangement of bus doors, the fare collection methods, the concentration of boardings at critical stops, and operating practices (see Appendix A for further details). The capacities associated with particular kinds of running ways are the following:

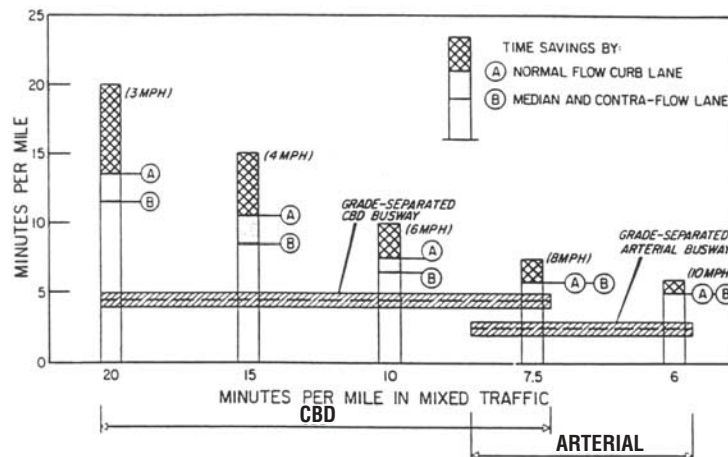
- Where buses operate nonstop along freeways, have well-designed entry and exit points, and have adequately sized terminals, flows of 750 to 800 buses per lane per hour can be safely accommodated.
- Busways with on-line stops and passing lanes at stations can carry over 200 buses per hour each way, provided that there is adequate capacity in downtown areas for buses.
- The South American experience indicates that median arterial busways with on-line stops and passing lanes at stops can carry over 200 buses per hour.

- Dual bus lanes on downtown streets carry 150 to 200 buses per hour total. Similar volumes can be carried in a single lane with more frequent stops if there is off-board fare collection, noncash fares, and multidoor boarding.
- Curb bus lanes on city streets typically can accommodate a maximum of 90 to 120 buses per hour.

**3-1.4. Bus Design Parameters**

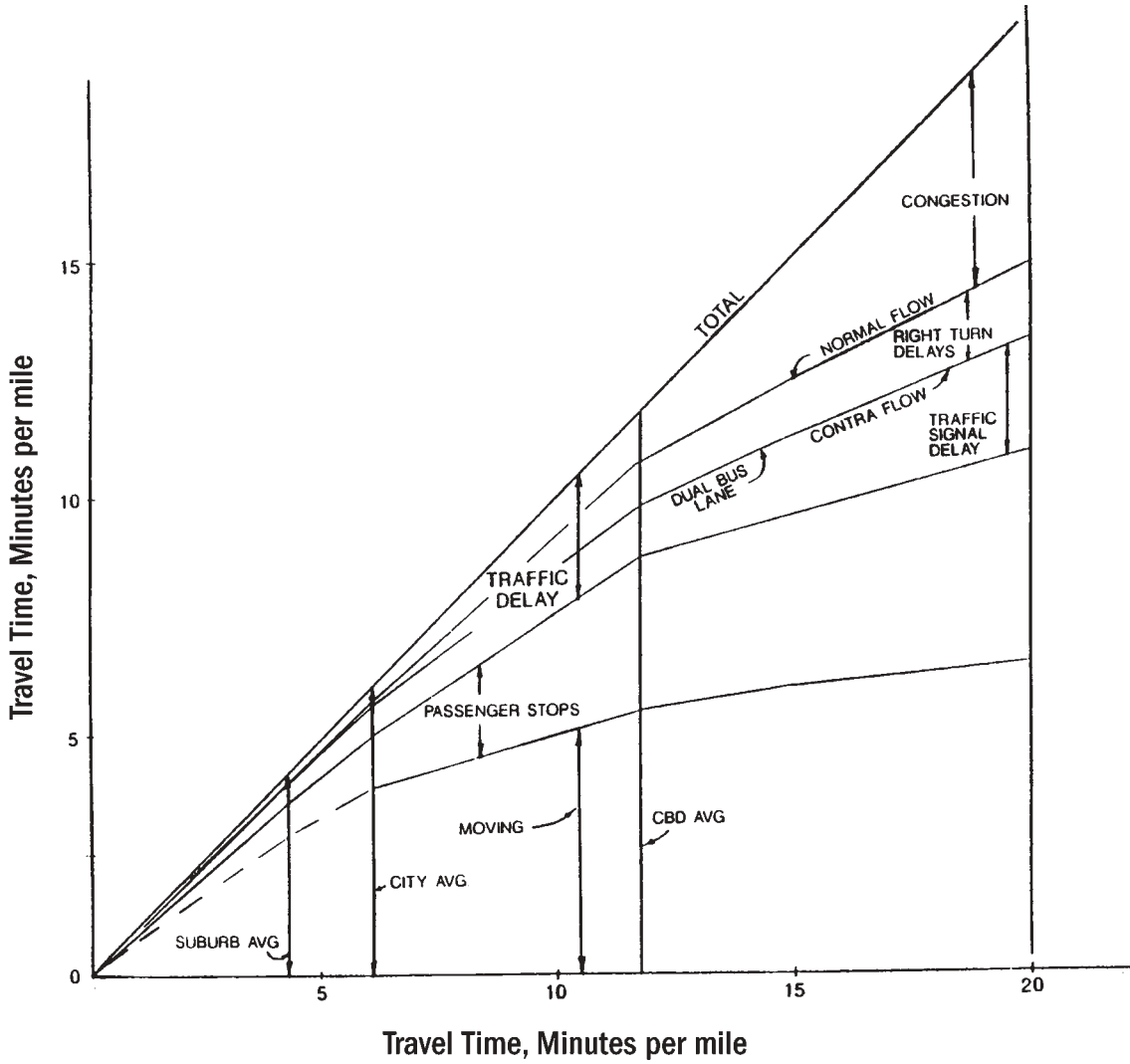
Running way planning and design should reflect the characteristics and capabilities of buses currently in operation and those planned for BRT service. Figure 3-7 shows an example of a typical 60-foot articulated bus that would govern BRT running way design. Additional examples of design vehicles can be found in *NCHRP Report 414: HOV Systems Manual* (Texas Transportation Institute et al., 1998) published by the Transportation Research Board (see Chapter 6 for a further discussion of BRT vehicles). Tables 3-4 and 3-5 provide select design and performance characteristics, respectively. Further details are contained in Appendix C. These exhibits suggest the following general guidelines:

1. *Length and Height.* The design single-unit bus is 40 feet long, and the design articulated bus is 60 feet long (the dual articulated buses in use in South America have a



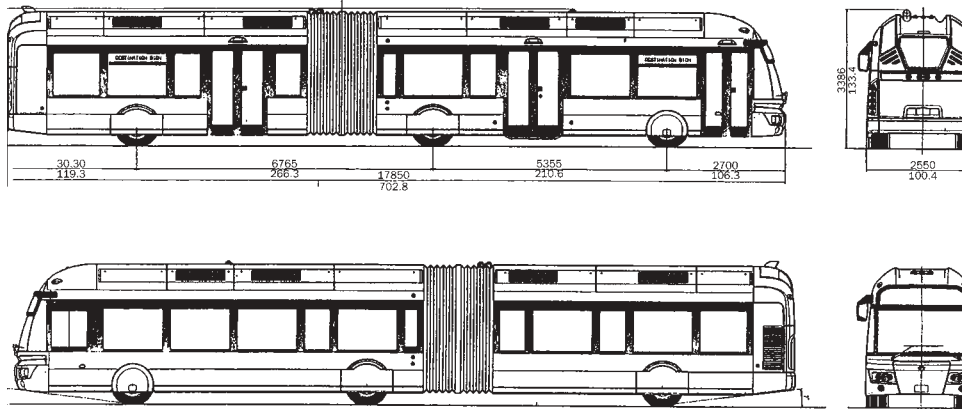
(SOURCE: Texas Transportation Institute et al., 1998)

Figure 3-5. Typical time savings—bus ramp transit options.



(SOURCE: St. Jacques and Levinson, 1997)

Figure 3-6. Bus travel time rates by time component.



(SOURCE: North American Bus Industries, Inc.)

Figure 3-7. Bus vehicle designs.

**TABLE 3-4 Bus design characteristics**

VEHICLE DIMENSIONS (All measurements in feet, unless otherwise noted)	40-FT REGULAR BUS	45-FT REGULAR BUS	60-FT ARTICULATED BUS
Length	40	45	60
Width without Mirror	8.5 <sup>(b)</sup>	8.5 <sup>(b)</sup>	8.5 <sup>(b)</sup>
Height (to top of air conditioning) for Design	9.8–11.1 <sup>(c)</sup>	12.5 <sup>(c)</sup>	11.0 <sup>(c)</sup>
Overhang			
Front	6.9–8.0 ft	7.9	8.8–8.9
Rear	7.5–9.5 ft	9.8	8.6–9.7
Wheel Base–Rear	23.3–24.9	22.9	23.3–24.5
Driver's Eye Height	7 <sup>(a)</sup>	7 <sup>(a)</sup>	7 <sup>(a)</sup>
Weight (lbs)			
Curb Weight	27,000–28,200	38,150	38,000
Gross Weight	36,900–40,000	55,200	66,600
Entrance Steps from Ground	1.5	1.5	1.5
Ground to Floor Height	2.3	2.3	2.3
Passenger Capacity			
Seats	45–50	50	76
Standees (crush load)	20	28	38
Turning Radius			
Inside	24.5–30		27.3
Outside	42.0–47		39.8–42.0
Outside with Overhang	45.5–51		44.3
Number of Doors	2	2	2
Width of Each Door	2.3–5.0	2.5–5.0	2.5–5.0
Angles (degrees)			
Approach	10	10	10
Breakover	10	10	10
Departure	9.5	9.5	9.5

## NOTES:

<sup>(a)</sup> Used 5 feet for design.<sup>(b)</sup> With mirrors envelope becomes 10 to 10.5 feet.<sup>(c)</sup> Used 13 feet as minimum governing design clearance.SOURCES: *A Policy on Geometric Design*, 2001; *Design Criteria*, 2002; Fuhs, C., 1990; Levinson, et al., 1975.

design length of 80 feet). Buses are generally 11 feet high; a minimum vertical design envelope of 13 feet is suggested, which typically translates into 14 feet and 6 inches of vertical clearance to allow for pavement resurfacing. Where LRT operates, the vertical clearance should be a minimum of 16 feet under structures and 18 feet at street intersections.

2. *Width*. Buses are 8 feet and 6 inches wide. However, when mirrors are added for both sides, the bus envelope becomes 10 to 10.5 feet. Therefore, 11 feet is suggested as the minimum lane width. Wider bus lanes are desir-

able for areas with higher design speeds. If the mirror-to-mirror envelope on 102-inch buses can be the same as that for 96-inch buses, 10-foot lanes could be used when space is constrained and speeds are low.

3. *Eye Height*. An eye height of 5 feet should be used in roadway design, although the driver's eye height on most buses is approximately 7 feet. This allows a factor of safety for potential new equipment and for possible use of bus lanes and busways by other public transportation vehicles (e.g., minibuses, paratransit vans, or maintenance vehicles).
4. *Turning Radius*. The minimum outside turning radius of the front overhang of an articulated bus has been reported to be about 45 feet. A slightly larger radius (e.g., 50 to 55 feet) should be used for design purposes.
5. *Acceleration and Deceleration*. Normal bus acceleration of 1.5 miles per hour per second and normal deceleration of 2.0 miles per hour per second should be assumed. Maximum deceleration in emergencies should not exceed 5 to 6 miles per hour per second when there are standing passengers. These rates reflect the performance capabilities of most urban transit buses and permit buses to accelerate to 30 miles per hour in 20 seconds.

**TABLE 3-5 Bus performance characteristics**

Item	
Maximum Attainable Speed (mph)	50–70
Acceleration (mph/sec)	
0–10 mph	3.33
10–30 mph	2.22
30–50 mph	0.95
Deceleration (mph/sec)	
Normal	2–3
Maximum	6–2
Maximum Grade (%)	10%

### 3-2. ON-STREET RUNNING WAYS

On-street BRT running ways can provide downtown and residential distribution. They can serve corridors where market factors, costs, or right-of-way availability preclude providing busways (or reserved freeway lanes). They also may serve as the first stage of future off-street BRT development and to establish ridership during the interim. Running ways vary in (1) whether they provide special facilities for buses; (2) how they place bus lanes (curb or median); (3) direction of flow (concurrent or contra); (4) mix of traffic (buses only, buses and taxis, and buses and goods delivery vehicles); and (5) traffic controls (parking, turn controls, loading, and signalization).

Running ways include (1) operation in mixed traffic, (2) concurrent flow bus lanes, (3) concurrent “interior” bus lanes, (4) contra flow bus lanes, (5) median bus lanes, and (6) arterial median busways. Running ways are a logical component of traffic management strategies that specialize street use and give preference to public transport.

The reasons for giving buses priority on streets and highways are (1) maximizing total person-carrying capacity of the street or highway, (2) minimizing net total all-mode person delay, (3) helping protect public investments in transit by maintaining service reliability and high speeds, and (4) favoring public transport for environmental preferences.

#### 3-2.1. General Guidelines

The following factors should be considered in achieving effective BRT use of city streets and suburban roads:

1. *General traffic improvements and road geometric design should be coordinated with BRT service to improve the overall efficiency of street use.* Typical improvements include prohibiting curb parking, adding turning lanes, prohibiting turns, modifying traffic signal timing, and providing queue bypasses for buses.
2. *Curb parking generally should be prohibited before (curb) bus lanes are established, at least during peak hours.* The prohibition (1) makes it possible to provide a bus lane without reducing street capacity for other traffic, (2) reduces delays and marginal frictions resulting from parking maneuvers, and (3) gives buses easier access to stops. (When prohibiting curb parking is not practical, the bus lane should be provided in the lane adjacent to the parking lane.) Bus lanes offset from the curb can provide benefits without parking and access restrictions. The trade-off is potential conflicts between parkers and buses.
3. *Bus routes should be restructured as necessary to make effective use of bus lanes and bus streets.* When BRT vehicles exceed 40 buses per hour, they should have exclusive use of the running way lane. When service is less frequent, it may be desirable to operate local buses on the same facility. However, this should

not create bus-bus congestion or create passenger inconvenience. Peak-hour one-way bus volumes ranging from 60 to about 75 buses will help “enforce” bus lanes without excessive bunching of buses.

4. *Bus priority treatments should reduce both the mean and variability of average journey times.* A 10 to 15% decrease in bus running time is a desirable objective for bus lanes.
5. *Extended bus lanes are necessary to enable BRT schedule speeds to achieve significant time savings, better service, reliability, and increased ridership.* A savings of 1 minute per mile (equivalent to raising bus speeds from 10 to 12 miles per hour) could produce a 5- to 6-minute time savings if achieved over the entire length of a typical 5-mile bus journey. Additional savings could result from traffic signal priorities. Time savings can translate into higher ridership/revenue and lower costs.
6. *Emergency vehicles, police cars, fire equipment, ambulances, and tour buses should be allowed to use bus lanes and bus streets.*
7. *Design and operation of bus lanes must accommodate the service requirements of adjacent land uses.* Deliveries should be prohibited from bus lanes during the hours that the lanes operate. They can be provided from the opposite side of the street, from side streets, or, ideally, from off-street facilities. Accommodating deliveries is especially important when contra flow lanes are provided.
8. *Access to major parking garages should be maintained.* This may require limited local automobile circulation in the block adjacent to garages.
9. *Taxi loading areas should be removed from bus lanes where they would interfere.* On one-way streets the taxi loading areas should be placed on the opposite side of the street.
10. *Pedestrian access to bus stops and stations should be convenient and safe.* Curbside stops should allow sufficient space for waiting passengers, passing pedestrians, and amenities. Crosswalks to reach median bus lanes and busways should be placed at signalized locations with pedestrian cycles and be designed to discourage errant crossings.
11. *Running way design should reflect available street widths and traffic requirements.* Ideally, bus lanes should be provided without reducing the lanes available to through traffic in the heavy direction of flow. This may entail eliminating parking or reducing lane widths to provide additional travel lanes, eliminating left-turn lanes, and/or providing reversible lane operation.
12. *When buses preempt moving traffic lanes, the number of lanes taken should be kept to a minimum.* The exception is when parallel streets can accommodate the displaced traffic.
13. *Bus lanes and streets should provide a strong sense of identity.* When buses have exclusive use of the lane, a

strong sense of identity can be achieved by using colored pavement, unique paving materials, signals, and pavement markings in various combinations. Such treatments are especially important for curb bus lanes whenever the lanes operate at all times.

14. *Effective enforcement and maintenance of bus lanes and bus streets is essential.* Fines for unauthorized vehicles should be high enough to discourage illegal use.
15. *BRT bus lanes (and streets) should operate all day wherever possible.* This will give passengers a clear sense of bus-lane identity and permit use of specially colored pavements.
16. *Far-side bus stops generally should be provided.* They are essential when there are traffic signal priorities for buses, as well as along median arterial busways where left-turn lanes are located near-side and where there are queue jumpers. Far-side bus stops are desirable when curb lanes are used by moving traffic and at locations with heavy right-turn traffic.
17. *Reserving lanes and/or bus streets for buses must be perceived as reasonable by users, public agencies, and the general public.*

Concurrent flow bus lanes should be at least 11 feet wide for 8.5-foot-wide buses; 12- to 13-foot-wide bus lanes are desirable. Contra flow bus lanes should be at least several feet wider in areas of heavy pedestrian flow to provide a cushion between the bus lanes and opposing traffic and to let buses pass around errant pedestrians in the lanes. Bus streets and median arterial busways should be at least 22 feet wide.

Median bus lanes need physical separation from general traffic for maximum effectiveness and enforceability. Therefore, physically separated median arterial busways are desirable. Passenger loading and unloading islands at stops should meet Americans with Disability Act (ADA) requirements. Roadways should be at least 75 to 80 feet wide, and it is preferable that they are wider.

### 3-2.2. Mixed Traffic Operations

BRT may operate in mixed traffic flow when physical, traffic-environmental conditions preclude busways or bus lanes, when streets and roads flow freely on “branch” BRT lines, and in residential collection. Advantages include low costs and fast implementation. However, such operations can limit bus speeds, service reliability, and route identity and should be used sparingly in trunk-line BRT service. Examples include the Wilshire-Whittier and Ventura Boulevard Metro Rapid services in Los Angeles.

Buses will usually benefit from street and traffic improvements that reduce overall delay. The range of transit-related traffic improvements includes the following: grade separations to bypass delay points, street extensions to improve traffic distribution or to provide bus routing continuity, traffic signal improvements such as system coordination and bus pri-

orities or preemptions; intersection channelization improvements, turn controls that exempt buses, bus stop lengthening or relocation, longer curb radii and corner rounding, effective enforcement and extension of curb parking regulations (especially during peak periods), and improved spacing and design of bus stops.

It is generally better to operate buses in both directions on the same street from a standpoint of service clarity and identity. However, one-way traffic flow generally improves travel speeds and safety and may be essential in central areas.

#### 3-2.2.1. Bus Bulbs

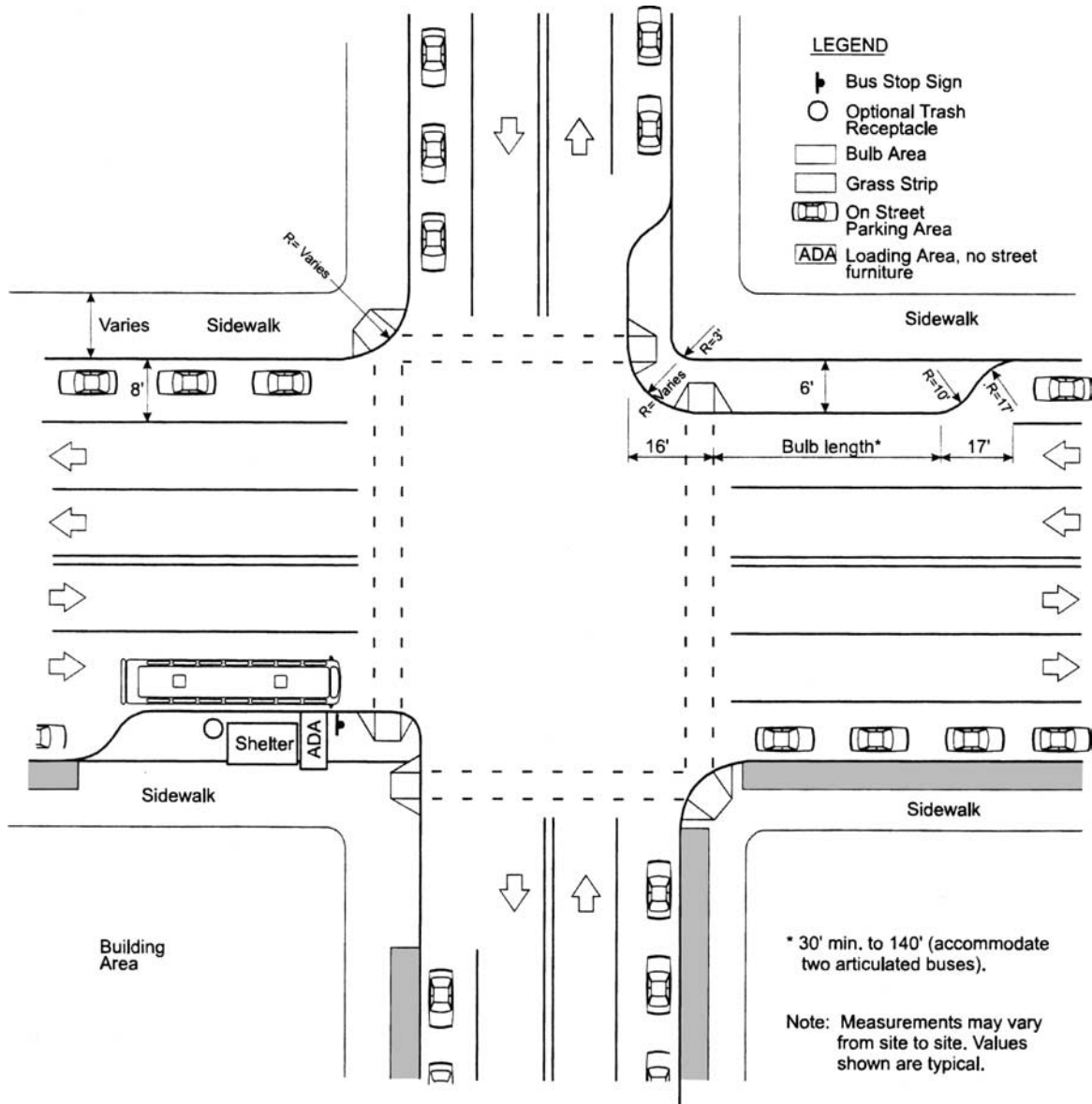
A bus bulb, a section of sidewalk that extends from the curb of a parking lane to the edge of an intersection or offset through lane, may have several advantages for BRT operations. These advantages include (1) creating additional space for pedestrian amenities at stops, (2) reducing street crossing distances for pedestrians, (3) eliminating lateral changes of buses to enter and leave stops, (4) eliminating delays associated with buses reentering a traffic stream, and (5) segregating waiting bus passengers from circulating pedestrian flow along the sidewalk. However, bus bulbs may also produce traffic queues behind stopped buses that can cause drivers to make unsafe maneuvers when changing lanes to avoid a stopped bus. Bus bulbs may also preclude adding capacity for moving traffic, and they may cost more than conventional bus stops because of street drainage requirements.

Supporting conditions for bus bulbs include (1) frequent bus service, (2) high passenger boardings and alightings, (3) sidewalks, (4) low traffic operating speeds, (5) two travel lanes each way to facilitate passing of stopped buses, and (6) difficult bus reentry into the traffic stream (Fitzpatrick et al., 2001). They also can be used when interior lanes rather than curb bus lanes are provided.

Typical designs for bus bulbs are shown in Figures 3-8a and 3-8b. The “bus bulbs” should be 6 feet wide, leaving a 2-foot offset between the bulb and the edge of the travel lane. Bus bulbs should be long enough to accommodate *all* doors on buses. Bus stops that are 140 feet long can accommodate two articulated buses. The “transitions” to the existing curbs should be about 15 to 20 feet long and consist of two-reverse curves.

#### 3-2.2.2. Queue Bypasses

Queue bypasses (queue jumpers) may be used at signalized locations or other locations (e.g., at a narrow underpass or bridge) where traffic backs up during peak hours. The queue bypass could be shared with right turns; however, when right turns are heavy and/or operate when through traffic is stopped, separate right-turn and queue bypass lanes should be provided. Adequate distance should be provided on the far side of the intersection to enable easy reentry of buses. Bus stops should



(SOURCE: Fitzpatrick et al., 2001)

Figure 3-8a. Bus bulbs with near-side stops.

be removed from the intersection. An “advance green” for buses could be provided when actuated by buses. The queue bypass should be distinctively identified by special pavement delineation. Queue bypasses should be used sparingly because they must be constantly enforced. Figure 3-9 shows typical queue bypass concepts; further details are contained in Chapter 4.

**3-2.3. Concurrent Flow Curb Bus Lanes**

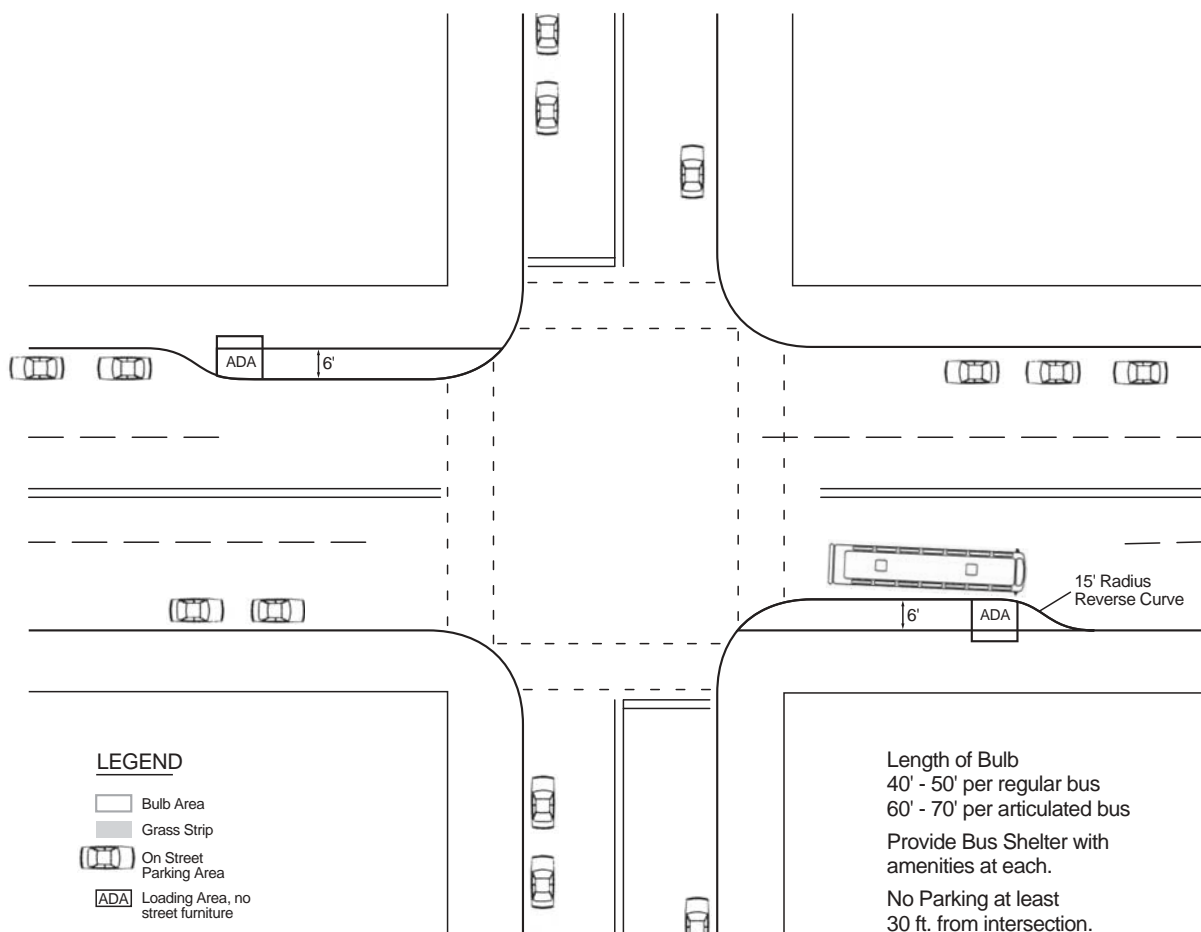
Concurrent flow bus lanes have been the most common type of bus priority treatment and can expedite BRT flow. Traditionally, they have been used to facilitate bus movements in

CBDs by segregating buses from other traffic; however, they are also used along outlying arterials.

*3-2.3.1. Design Features*

Concurrent flow bus lanes can operate at all times or just during peak hours. On one-way and two-way streets, an 11- to 13-foot bus lane should be provided along the curb (see Figure 3-10). However, when street width permits and there are high demands for curb access, a 20-foot-wide curb bus lane should be provided to enable buses to pass loading and unloading cars and trucks. (This arrangement is used in downtown San Francisco.)





(SOURCE: Fitzpatrick et al., 2001)

Figure 3-8b. Bus bulb with far-side stops.

When street width and circulation patterns permit and peak bus volumes exceed 90 to 100 buses per hour, dual bus lanes should be considered. This arrangement is used along Madison Avenue in midtown Manhattan. It enables buses to pass each other safely, makes express stops and skip stops feasible and reduces the magnitude and variance of bus travel times. However, dual lanes preclude right turns by general traffic. When BRT and local buses use the same street and space permits, it may be desirable to provide turnouts for local bus stops.

Curb lanes can be separated by solid white lane lines, by paving material with a different color or texture, or sometimes by raised curbs. The lines should be broken where right turns are permitted. Photo 3-A shows an example of a running way for the Boston Silver Line.

Every effort should be made to eliminate turning movements that would impede bus service. Ideally, right turns should be prohibited when there are more than 300 pedestrians per hour in the conflicting crosswalk (see Chapter 4). Left turns by general traffic should be prohibited on four-lane streets unless special turn lanes are provided.

### 3-2.3.2. Assessment

Concurrent flow curb bus lanes are the easiest to implement and have the lowest installation costs because they normally involve only pavement markings and street signs. They occupy less street space than most other types of bus lanes. Although these lanes are commonly used only during peak hours, they should operate throughout the day along BRT routes.

Concurrent flow curb bus lanes are usually least effective in terms of image afforded and travel time saved. They are difficult to enforce and may impact curb access. Another disadvantage is that right turns, when permitted, may conflict with bus flow.

### 3-2.4. Contra Flow Curb Bus Lanes

Contra flow bus lanes enable buses to operate opposite to the normal traffic flow on one-way streets. They may be used for a single block on two-way streets to enable buses to reverse direction. They are used for distribution of busway and BRT vehicles in downtown Los Angeles and Pittsburgh. The lanes

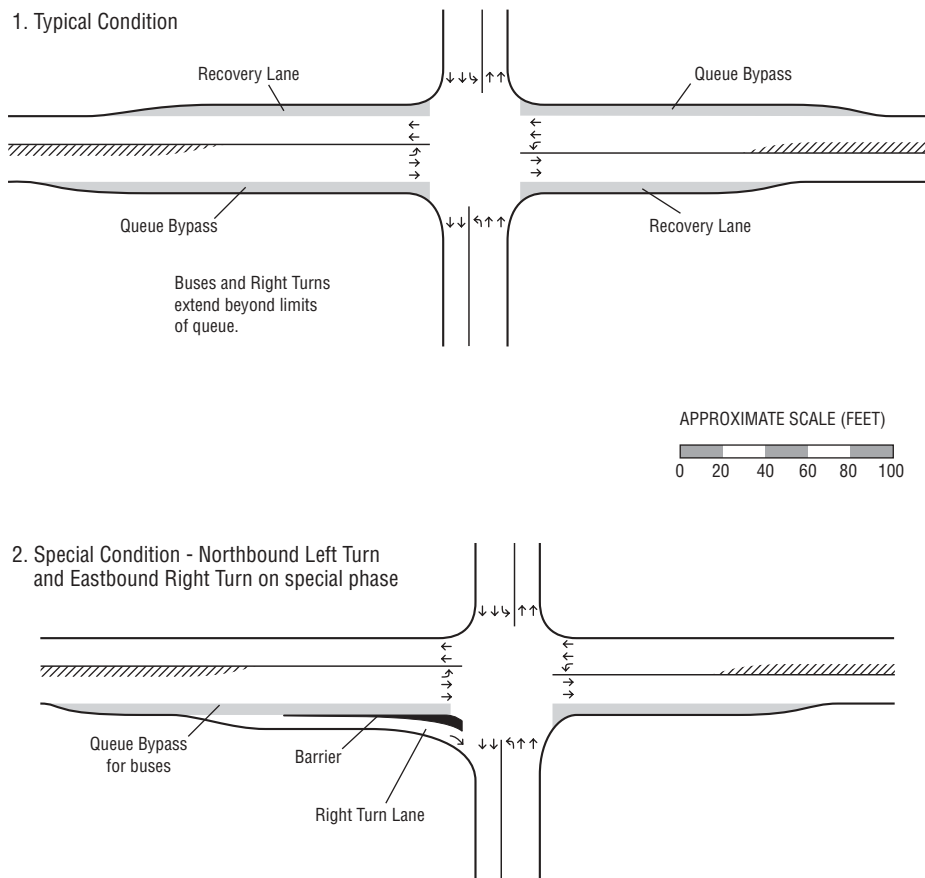


Figure 3-9. Queue bypass concepts.

normally require one-way street systems with reasonable spacing between signalized intersections, generally 500 feet or more. They usually operate at all times.

#### 3-2.4.1. Design Features

Typical contra flow lane designs are shown in Figure 3-11. Contra flow bus lanes should be at least 12 feet wide. However, a 13- to 15-foot-wide lane is desirable to let buses pass around pedestrians who step off the curb. Left turns in the opposing direction of travel should be prohibited unless protected storage lanes and special traffic signal phases are provided. Loading of goods should be prohibited from the lanes at all times unless special space is provided for midday loading.

Contra flow lanes may be provided in the interior lane offset one lane from the curb in places where delivery and service vehicles must use the curb lane. This improves the ability to provide access to adjacent properties and improves pedestrian safety, although it requires an extra lane of road space. Such a treatment was installed on Sansome Street in downtown San Francisco in 1997.

Because pedestrians will be conditioned by the appearance of one-way traffic operation, precautionary measures are

necessary to reduce the probability of accidents, especially when the lanes are first installed. Accordingly, special signs may be needed at major pedestrian crossings. Buses should operate with their headlights on at all times so they can be seen more easily by pedestrians. This method of operation is used along Spring Street in Los Angeles.

Pedestrian safety can be improved by (1) strict enforcement of “jay-walking” ordinances, (2) signage and marking that warns pedestrians to “look both ways” at designated crosswalks, (3) special visual or audible warning devices installed on contra flow lane buses, and (4) a special yellow stripe 1 to 2 feet wide with “bumps” for pedestrians who are sight impaired and a warning message painted on the sidewalk adjacent to the curb.

#### 3-2.4.2. Assessment

Contra flow lanes retain existing bus routes when new one-way street patterns are instituted, allow new bus service on existing one-way streets, utilize available street capacity in the off-peak direction of flow, and permit passenger loading on both sides of one-way streets, thereby increasing curbside bus loading capacity. Buses are removed from other traffic flows and are not affected by peak-hour queues at signalized

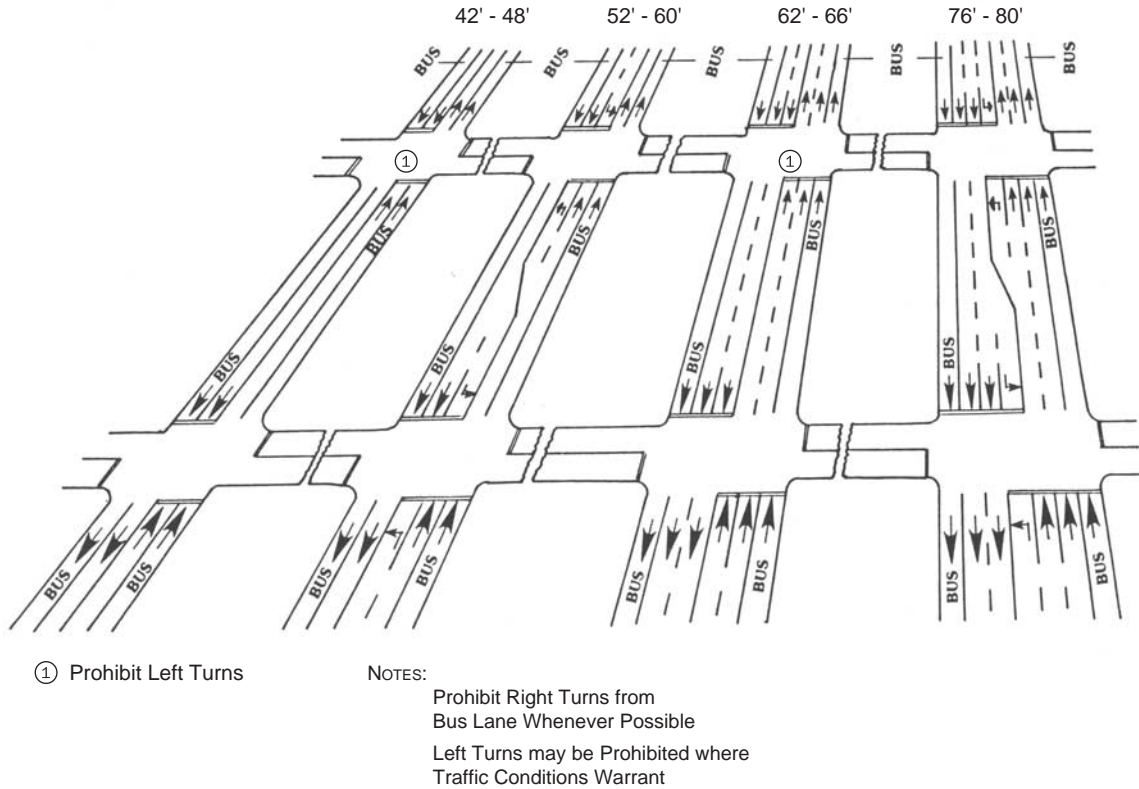


Figure 3-10. Concurrent flow curb bus lanes for two-way streets.

intersections. The lanes provide a high degree of bus service reliability and identity.

Contra flow lanes can allow direct bus routings with savings in bus miles, hours, and operating costs. They are “self-enforcing” because the presence of violators is easily detected. Although they can be used along radial arterial street couplets, buses would operate counter to the established traffic signal progression, and this could limit BRT speeds.

Contra flow lanes have a mixed accident history. When the lanes operate on a street that previously was two way, total

accidents drop. When the lanes operate on a street that previously was one way, an increase may occur, especially initially. The predominant cause of accidents is the inability of crossing pedestrians to recognize a street’s “wrong way” operation. These individuals may scan for traffic in the general traffic direction when crossing and fail to look for contra flow bus traffic. These perceptual deficiencies occur because the design of contra flow facilities violates basic driver and pedestrian expectancy.

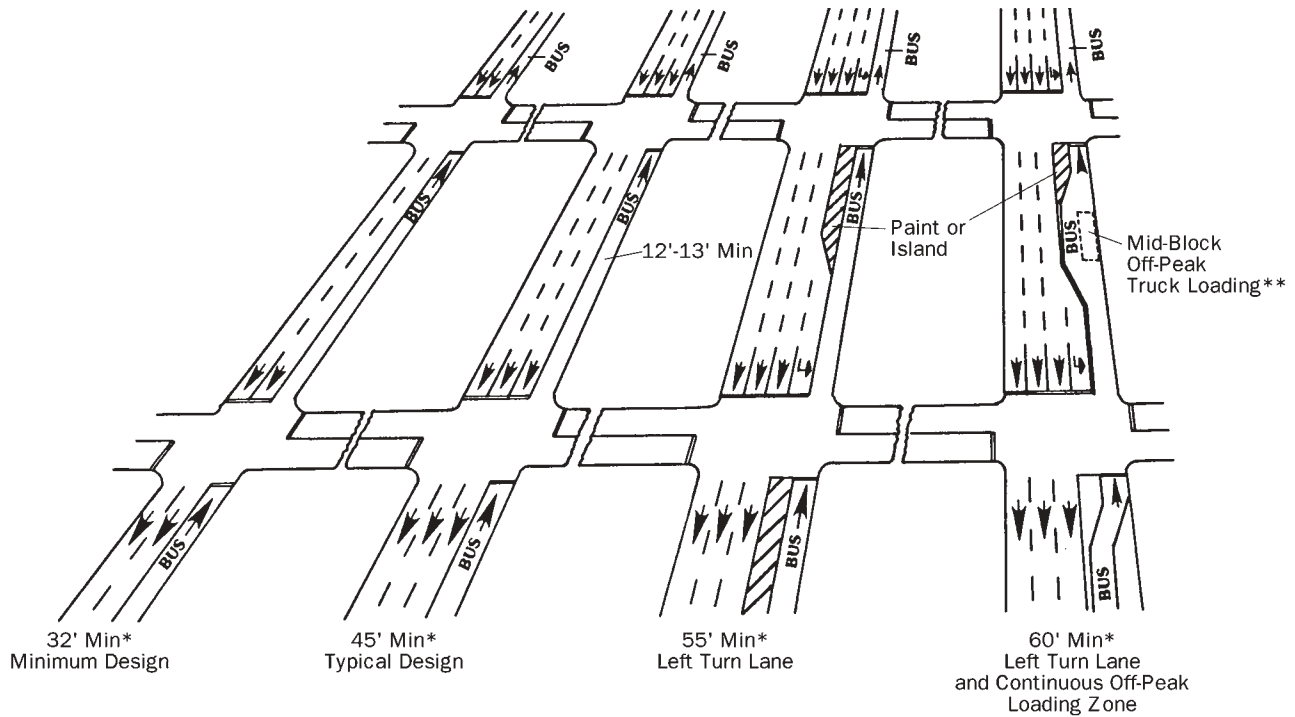
From a BRT perspective, the lanes have several disadvantages: (1) they disperse buses onto two different streets, thereby detracting from BRT identity; (2) passing stopped or disabled buses is difficult unless dual bus lanes are provided; and (3) buses run “against” the traffic signal progression, although this can be partially offset.

3-2.5. Concurrent Flow—Interior Bus Lanes

There are situations where curb parking must be retained. In these cases, concurrent flow interior BRT lanes can be provided adjacent to the parking lane on both one-way and two-way streets. Examples of such lanes are found in downtown Ottawa and along Washington Street in Boston, where they serve the Silver Line BRT. Photo 3-B illustrates the part of Boston’s Silver Line running way where curb parking is retained.



Photo 3-A. Curb bus lane, Silver Line, Boston.



\* Add 2-3 feet in areas with heavy pedestrian flow  
 \*\* Alternatively provide loading from highway lane side. Can also serve as bus bypass lane.

Figure 3-11. Contra flow bus lane designs.

3-2.5.1. Design Features

Concurrent flow interior lanes should be at least 11 feet wide and be clearly delineated by pavement markings, texture and/or color. Figure 3-12 gives a rendering of interior bus lanes on a multilane street. It is desirable to provide left-turn lanes wherever space permits; this results in a minimum cross section of about 60 feet (without left-turn lanes) and a cross section of 70 feet when turn lanes are provided. The bus lanes can be delineated by special pavement colors. Effective



Photo 3-B. Interior bus lane, Silver Line, Boston.

enforcement is essential because the lanes—unlike contra flow lanes—are not self-enforcing.

3-2.5.2. Assessment

Interior bus lanes remove buses from curb lane conflicts with often illegally parked vehicles, provide for unrestricted access to adjacent properties, and do not affect left-turn access. Right turns can be permitted from the bus lane or provided in the curb lane by prohibiting curb parking on the intersection approach. Bus bulbs can be provided on the far side of intersections for stops and stations. The downside of interior lanes is that if parking is permitted (e.g., in the off-peak period), there may be conflicts with parking and/or idling cars.

3-2.6. Median Bus Lanes and Median Arterial Busways

BRT can operate in the center of streets in median bus lanes or median arterial busways. Median lanes may be delineated by painted lines for exclusive bus use. Although median arterial busways are physically segregated from adjacent street traffic lanes, the running ways are sometimes used by streetcars and LRT. It can be a challenge to provide pedestrian access to stations and deal with left turns, whether they are used by BRT, streetcars, or LRT. Both median bus lanes and

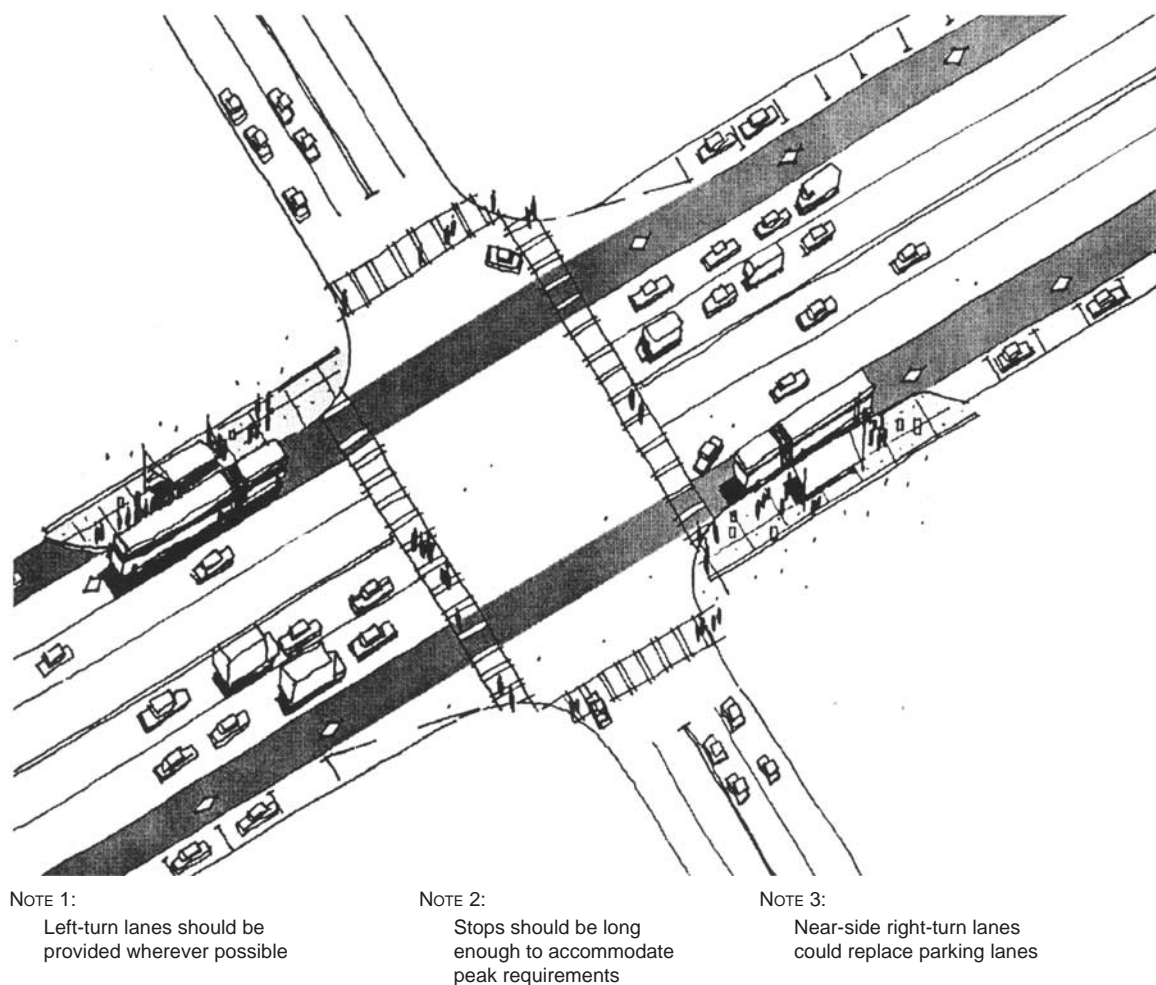


Figure 3-12. Interior bus lanes.

median arterial busways can provide attractive running ways and stations.

The median bus lanes have continuous access, making enforcement difficult, but providing routes around disabled buses (e.g., back into mixed traffic). Segregated median arterial busways are easier to enforce and provide a clear sense of identity. Both facilities superimpose at least three- to four-lane-wide envelopes, including platforms at on-line stations and off-line on the available street space. When passing lanes for buses are provided—as in South American cities—additional street space is required. Photo 3-C illustrates the passing capabilities of the running ways used in the Bogotá TransMilenio system. The actual street envelope (curb-to-curb width) depends on (1) how many lanes must be reserved for general traffic on each side of the busway and (2) whether left turns can be prohibited at stations.

### 3-2.6.1. Background and Examples

Perhaps the first median bus lane in the United States operated along Washington Street in downtown Chicago from the early 1950s to the mid-1970s. Canal Street, in New Orleans,

is the best example of a median arterial busway. The “neutral ground” on this 140-foot-wide street was converted from streetcar to bus-only operation in 1966, although streetcar service is scheduled to resume in 2004.

A section of Number Three Road in Richmond, British Columbia (a Vancouver suburb), has an arterial median busway (see Photo 3D). Cleveland is planning median bus lanes on Euclid Avenue (with an approximately 100-foot right-of-way) that will be separated from general traffic flow by a 1-foot rumble strip. Examples of median running ways are illustrated in Photo 3-E (the Rouen system) and Photo 3-C (median running ways on the TransMilenio system in Bogotá).

### 3-2.6.2. Operations

Median arterial busways for BRT should have two-way operation. Reversible one-way lanes along two-way streets can be used in situations in which bus service is provided “inbound” in the a.m. peak and “outbound” in the p.m. peak (e.g., to/from Montreal’s “Pie IX” metro station), but these are unlikely situations for most BRT applications. The bus lanes should be used only by BRT vehicles, with local buses



Photo 3-C. Median arterial busway, Bogotá.

using the outside roadways. However, when the total peak-hour, one-way bus volumes are less than 20 buses, both local and BRT service can use the lanes.

### 3-2.6.3. Design Envelopes

The curb-to-curb width at stations should be based on the parameters listed below.

Curb Access Lanes	8 feet each
Travel Lanes	10 to 12 feet each
Barriers	2 to 4 feet minimum
Left-Turn Lanes	10 feet
Two-Lane Busway	22 to 24 feet
Station Platform (side)	8 to 10 feet

Minimum curb-to-curb widths for typical design conditions are given in Table 3-6. They assume far-side bus stops offset on either side of intersections and near-side left-turn lanes where provided. The lower values give the *absolute* min-



Photo 3-D. Median arterial busway, Vancouver.



Photo 3-E. Median running way, Rouen, France, TEOR system.

imum width, and the higher values give the *desirable* minimum. Total curb-to-curb street widths generally range from 75 to 90 feet. In most situations, a 100-foot total width is desirable to provide wider lanes and/or space for landscaping. Guidelines for the design of bus lanes are as follows:

1. A single-curb traffic lane without any provision for access should be provided for only one or two blocks when road space is seriously constrained.
2. Ideally, left turns should be prohibited in station areas and provided elsewhere.
3. Left turns from general traffic lanes should be discouraged. When provided, they should be signal-controlled with special phases.
4. The “midblock” space within the busway, on each side of the median busway between the BRT running ways, could be devoted to bus passing lanes or parking.

### 3-2.6.4. Design Features

The design of median arterial busways should be keyed to the available total curb-to-curb street width and the need for left turns and curb access. Figure 3-13 gives a conceptual design for a wide arterial boulevard that provides these functions. It also identifies desired treatment for turn lanes and bus stops, signal controls, pedestrian access, “escape” lanes, and cross-street closures. The following features are illustrated:

1. Buses may join the general traffic flow at busway terminal points; however, special signal controls will be needed where buses turn right or left.
2. Intermediate right-turn entry and exit points to and from the outer roadway can be provided via slip ramps where space permits.
3. Right-turn exits from the busway via slip ramps should be located a sufficient distance from downstream traffic signals to enable buses to safely merge and weave across the roadway to enter the outermost lane.

**TABLE 3-6 Minimal roadway envelopes for median arterial busways (curb to curb)**

Design Condition	Left Turns Prohibited	Left Turns Provided
<b>Single Traffic Lanes Each Side</b>		
No Parking	64–68	74–78
With Parking Lane	68–74	78–84
<b>Two Traffic Lanes Each Side</b>	76–84	86–90

**NOTES:**

Lower values for 8-foot loading platform, 2-foot separation, 18-foot parking plus travel lane.

Higher values for 10-foot loading platform, 4-foot separation, 19-foot parking plus travel lane.

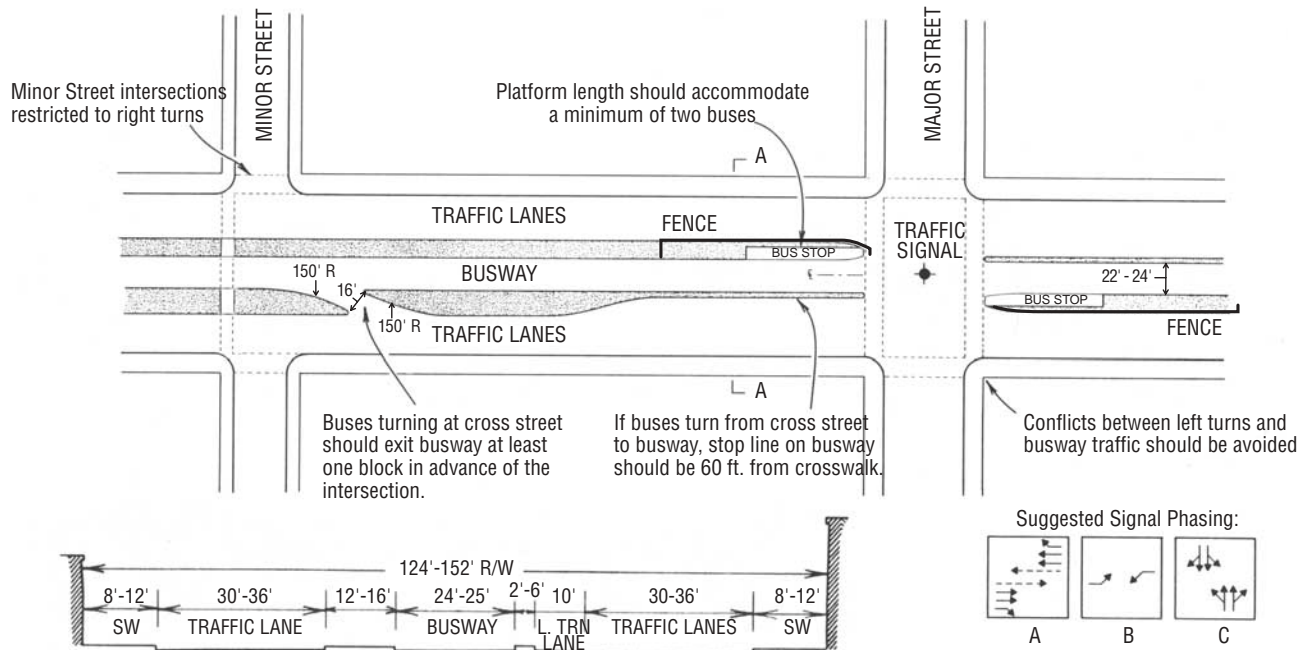
4. Traffic signals should control movements at crossing roads. Buses should move on the green phase for through traffic that is *followed* by the left-turn phase. (This sequence is essential to minimize same-direction bus-automobile crashes.)
5. Pedestrian access to the stations should be provided at signalized intersections.
6. Traffic signal-controlled, near-side, left-turn, storage lanes are shared with the far-side bus station platforms; special signal phases should be provided wherever left turns must be accommodated.
7. Bus stops located in the islands must have passenger protection, and fencing is desirable to channel pedestrian entry and exit to intersection crosswalks.

Most rights-of-way will require more limited space designs; however, the same basic principles apply. Figures 3-14a and 3-14b show more likely configurations. Figure 3-14a illustrates a configuration with left-turn lanes, and 3-14b illustrates a configuration without left-turn lanes. These designs require

total rights-of-way widths of 100 to 105 feet and 90 to 95 feet, respectively, assuming 10-foot-wide sidewalks. When left turns are prohibited, the busway is offset about 6 to 8 feet; this offset decreases as the width of the median island increases. However, such lateral offsets should be minimized.

Physical separations may be provided by raised islands with mountable curbs. A minimum separation of 4 feet between the busway and adjacent travel lanes will provide refuge for pedestrians and space for signs. When space is extremely tight, channelization such as flexible posts placed in predrilled holes can be used. Far-side “transit” signal indications, such as those used for LRT lines, should indicate to bus drivers when they may proceed or must stop. This will minimize confusion to approaching motorists (see Chapter 4).

Passenger loading areas for bus stops should be adequate for expected peak-hour bus flows. Generally, they should provide at least two loading positions (100 feet for regular buses and 140 to 150 feet for articulated buses). Stops may be located either midblock or on the far side. They should be at least 8 feet wide; a 10-foot width is preferred.



(SOURCE: Adapted from Levinson et al., 1975)

Figure 3-13. Median arterial busway design for a wide roadway.

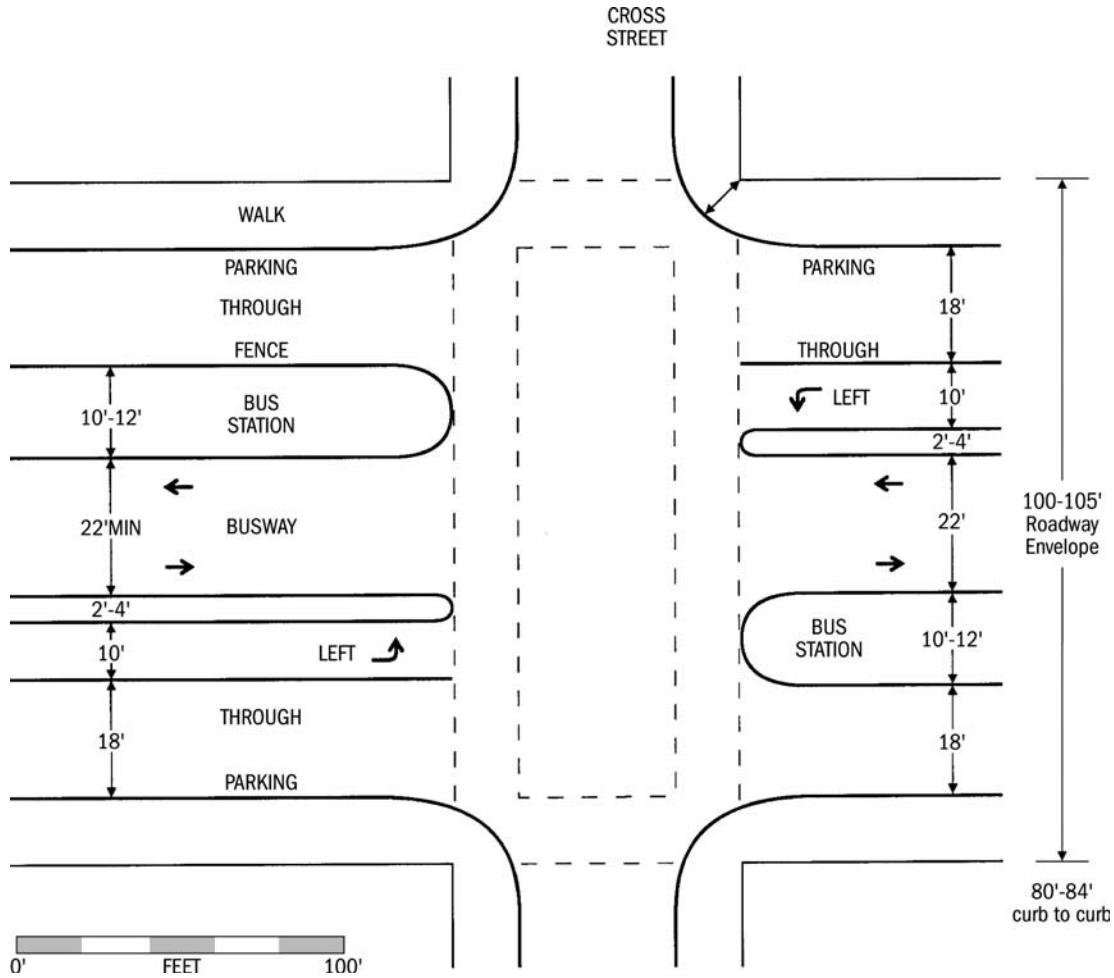


Figure 3-14a. Typical median arterial busway designs with left turns.

Figure 3-15 shows the “staggered” station platform design used in South America. The design provides a center lane for express buses; its direction alternates, resulting in a three-lane running way envelope.

3-2.6.5. Indirect Left Turns

Along arterial roads with wide median strips, “indirect” left turns can be provided to simplify intersection conflicts and traffic signal phasing. This treatment has applicability in growing suburban areas where new roadways are being developed and where BRT is being considered. The indirect-left-turn concept, as shown in Figure 3-16, is in effect along Canal Street in downtown New Orleans where buses run in the central “neutral ground.” It is also used extensively on highways with wide medians in Michigan, where benefits in capacity, travel times, and safety have been documented.

The indirect-left-turn concept prohibits all left turns at intersections and replaces them with far-side “U” turns coupled with a right turn; these kinds of turns are also known as indirect left turns. The indirect left turn permits simple two-

phase traffic signal operations at intersections. The “U” turns move on the same phase as the cross-street traffic. To make pedestrian access to stations safe and convenient, the “U” turn channels should not be provided at intersections with stations. The “U” turns should be placed where they have minimal impact on BRT service.

3-2.6.6. Assessment

Median arterial busways located in the center of the street eliminate the passenger loading, curb access, and right-turn problems associated with curbside lanes. They can be readily enforced and provide a strong sense of identity in running ways (preferably specially colored pavement) and stations. They can be grade separated at major intersections where space permits to eliminate traffic signal delays. They do, however, pose problems in dealing with left turns, and pedestrian access to stations is less attractive than with curbside stops. They also usually require total roadway rights-of-way of 90 to 100 feet. Such rights-of-way are not common in most North American cities.



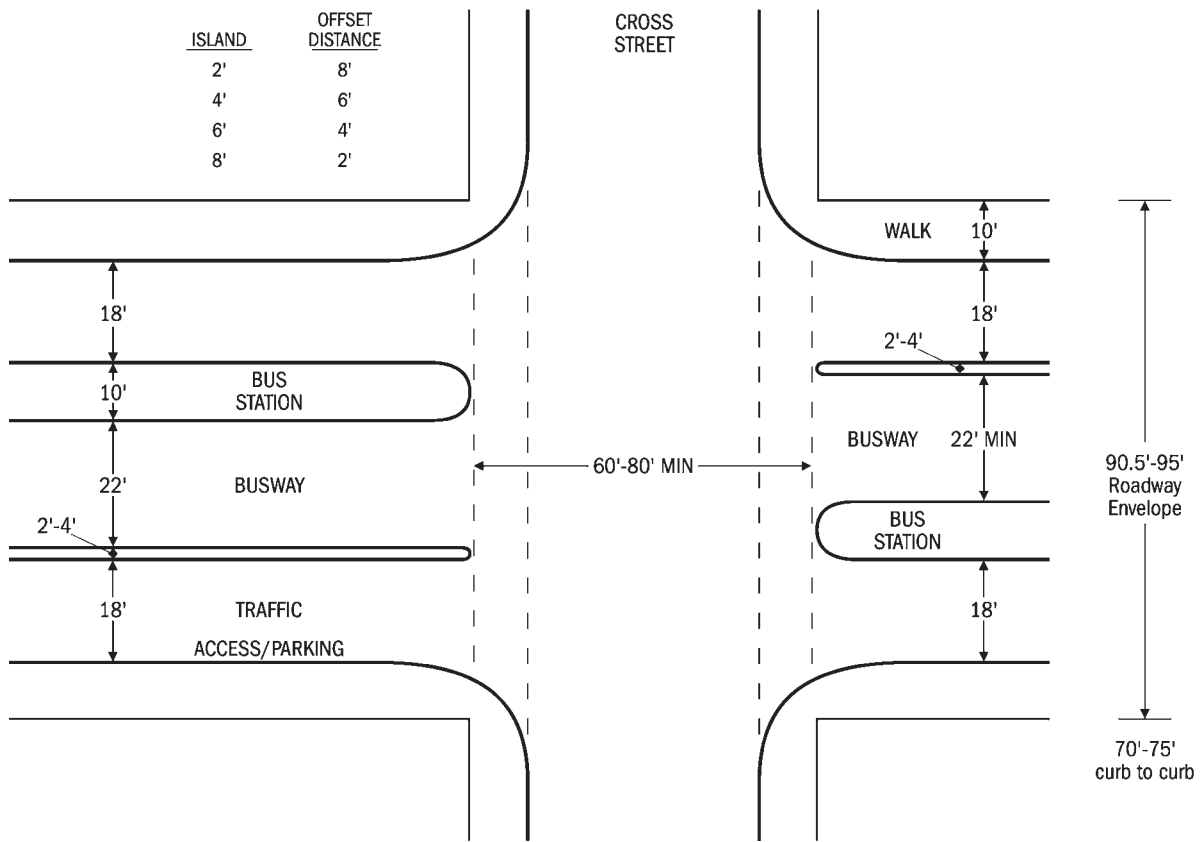
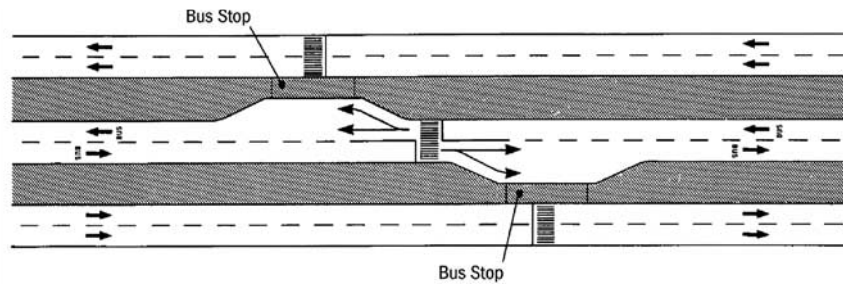
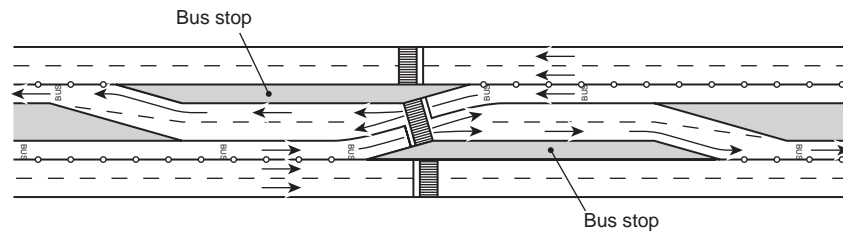


Figure 3-14b. Typical median arterial busway designs without left turns.



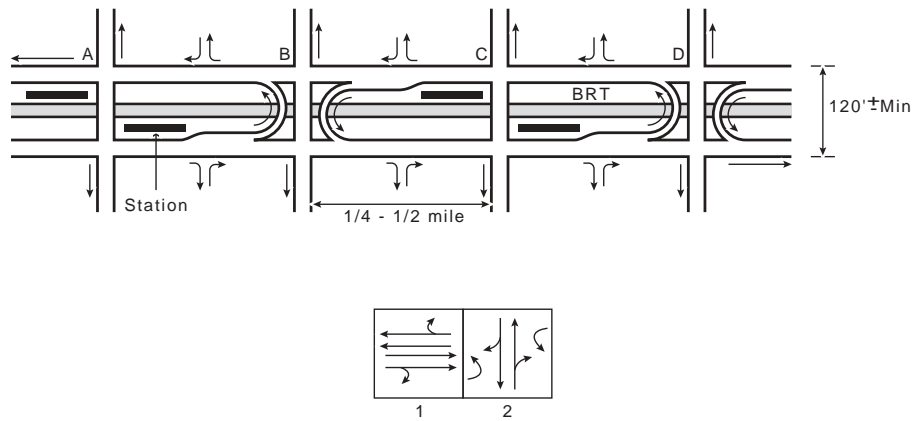
Typical Bus Stop Layout, Avenida Cristiano Machado, Belo Horizonte, Brazil



Typical Bus Stop Layout, Avenida 9 de Julho, São Paulo, Brazil

(SOURCE: Gardner et al., 1991)

Figure 3-15. Typical South American median arterial busway.



Signal Phasing at Locations A. B. C. D.

Figure 3-16. Indirect left-turn concept for median arterial busways.

### 3-2.7. Bus Streets

Bus streets or malls can provide early action cost-effective downtown distribution for both BRT and local buses. They may be warranted where high bus volumes traverse narrow streets or as part of downtown revitalization proposals. Bus streets or malls may include the last block of an arterial street, a dead-end street at the end of several bus routes, a “bus loop” to change directions at major bus terminals, downtown bus malls, and bus circulation through automobile-free bus zones.

Reserving streets for BRT and other buses can improve service speeds, reliability, and identity. Care must be taken to select streets that provide maximum advantage without hindering other traffic and access to adjacent premises. Generally, bus streets should serve major concentrations of bus flow resulting from the convergence of individual lines onto a single street. They should penetrate the heart of the city center to provide easy, direct pedestrian access to major activities. They provide logical passenger distribution for BRT running ways on radial arterials or freeways, and they should be integrally tied to pedestrian mall development.

#### 3-2.7.1. Rationale

Bus streets clearly identify transit routes, and they are easy to enforce. They enable buses to pick up and drop passengers at places where shopping and business activity is at the highest level. Bus streets are found in several U.S. cities and are used extensively throughout Western Europe. Examples in the United States include the Fulton Street Transitway in Brooklyn and the Nicollet Mall in Minneapolis.

Bus streets increase walking space for pedestrians and waiting space at bus stops and can be ideal locations for off-board fare collection. They can be part of an overall downtown improvement program that is designed to stimulate activity and investment. But as their use by buses increases, they tend to become less attractive for pedestrians. Bus streets

are a compromise between giving buses unhindered passage to carry passengers close to their desired destination and providing freedom of pedestrian movement.

#### 3-2.7.2. Property Access

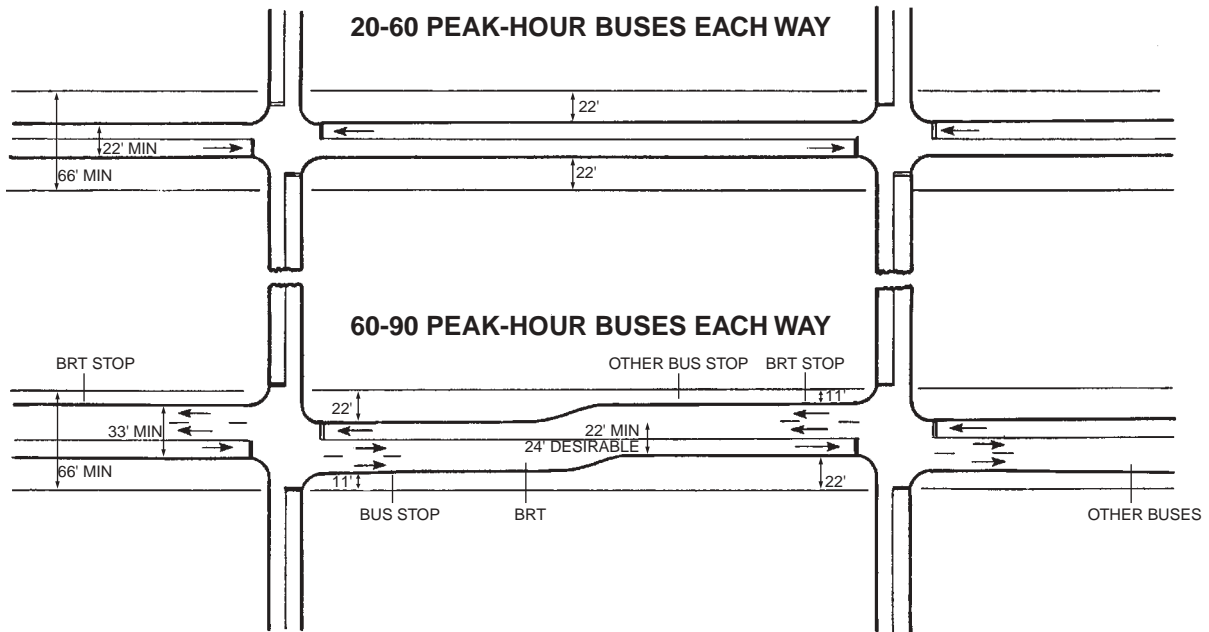
Bus streets should incorporate curb loading zones for off-peak service vehicles when the necessary service cannot be provided from intersecting streets or off of the street. When other options are not practical, pickups and deliveries can be permitted from the bus streets when the bus traffic is low (i.e., night hours).

Access to parking garages is a constraining factor that may require allowing automobiles on short discontinuous sections of street. Such an arrangement is incorporated in Portland Oregon’s dual lane, one-way, Fifth and Sixth Avenue bus streets where automobiles must turn off at the first cross street after leaving the parking garage.

#### 3-2.7.3. Design Features

Bus streets should provide passing opportunities around stopped buses when bus flows are heavy, the distances involved are more than ½ mile, and both BRT and other buses use the street. Stopping positions for BRT should be separated from those for local buses, but walking between them should be easy.

Illustrative designs are shown in Figure 3-17. Bus streets usually are 22- to 24-foot two-way roads. This configuration is adequate when there are less than 50 peak-hour buses one way. When there are more than 60 buses per hour, it is desirable to provide passing opportunities at stops. The stops may either lie near-side or far-side and should accommodate at least three articulated buses. When blocks are closely spaced, the stops may extend an entire block; however, designs should limit the passing opportunities to one lane. In cases of very



NOTE:  
If over 90 buses each way, dual-width lanes may be desirable.

Figure 3-17. Typical bus street designs.

heavy bus volumes (e.g., over 90 buses per hour), dual lanes are desirable in both directions. Specific designs can include bus pull-outs, central medians at key points, widened sidewalks, and passenger amenities. Care must be taken to ensure that other traffic is not unduly impacted and that parallel routes are available for displaced traffic. When the length of a bus street is less than three or four blocks, it may be feasible to eliminate cross vehicular movements if traffic flows on cross streets are low.

#### 3-2.7.4. Operations

Bus streets generally should operate at all times. However, during late evening and overnight periods, when bus flows are very light or there is no bus service, other vehicles could use the bus lanes. Operations and service design are described more fully in Chapter 8.

### 3-3. OFF-STREET RUNNING WAYS

Off-street BRT running ways are desirable in “line-haul” BRT operations to permit high speeds and to minimize traffic interferences. A desirable goal is to provide as much BRT route mileage as possible in reserved lanes or dedicated busways.

Rapid and reliable BRT service is best achieved when buses operate in busways or reserved lanes on freeways. Locations in order of desirability are (1) separate right-of-way, (2) one

side of freeway, and (3) within freeway medians. A major issue with freeway medians is poor pedestrian access to stations and the difficulty in integrating them with their surroundings to promote transit-oriented development. Busways have the advantages of better penetration of markets, a close relationship of stations to surrounding areas, and a stronger identity. Facilities in freeway corridors (reserved bus lanes) may be easier to develop because rights-of-way are already available.

BRT use of freeways will benefit from bus-only ramps to the BRT facility and metered ramps with bus bypass lanes. These ramps have the dual benefits of reducing bus delays and/or improving main-line flow. Other HOVs could also use the bypass lanes.

#### 3-3.1. Busways

Dedicated, often grade-separated busways provide the most attractive running ways for BRT. Busways permit fast, reliable bus operations that are free from traffic interference and afford speeds comparable to those provided by rail rapid-transit lines. They provide a strong sense of identity and can achieve collateral land development benefits.

Busways provide (1) line-haul BRT services to city centers, (2) BRT service that extends rail transit lines, and (3) short bypasses of major congestion points. They segregate buses from other types of traffic, and they include ancillary passenger-bus interchange and parking facilities. They

**TABLE 3-7 Busway riders needed to produce a net benefit**

Busway Cost (Millions of Dollars per Mile)	Time Savings, Min / Mile			
	1	2.5	5	7.5
10	<u>11,000</u>	<u>4,000</u>	22,000	1,500
25	<u>27,500</u>	<u>11,000</u>	5,500	27,000
50	<u>55,000</u>	<u>22,060</u>	110,000	7,300
Bus Tunnel				
200	220,000	88,000	<u>44,000</u>	<u>29,300</u>
300	330,000	132,000	<u>66,000</u>	<u>44,000</u>

NOTES:

Typical values are underscored.

Capital recovery: 50 years @ 5% interest, 300 days per year, \$10/hour value of time.

may be constructed at, above, or below grade (as in tunnels), either in separate rights-of-way or within freeway corridors. They may be designed as “open” systems that let buses enter or leave at intermediate points or as “closed” systems in which buses operate only on the busway. They may be fully or partially grade separated or entirely at grade.

*3-3.1.1. Planning, Location, and Configuration*

Busways should form the backbone of the BRT system whenever suitable corridors are available and a sufficient number of buses is available to establish a BRT “presence” along the corridor. Busways should save at least 5 minutes of travel time over alternate bus routings, on average. They are also desirable where freeways are congested and where physical, social, and/or environmental conditions preclude major road expansion. Downtown busway development (e.g., bus tunnels) may be appropriate when peak-hour bus speeds are less than 5 to 6 miles per hour, when the congested area extends for more than a mile, and when surface-street priority options cannot substantially improve speeds.

*3-3.1.2. Cost-Effectiveness*

The number of passengers along the busway and the estimated travel time savings should bear a reasonable relationship to the development costs incurred. Ideally, the travel time benefits, measured in the value of time saved for bus passengers, should exceed the annualized development and operations and maintenance costs. Typical cost-effectiveness values for busways and bus tunnels are shown in Table 3-7.

*3-3.1.3. Location Options*

Busways may be built on separate rights-of-way, alongside freeways, or within freeway medians. Locations in order of desirability are (1) separate right-of-way, (2) one side of a freeway, and (3) within freeway medians.

*Busways located on their own right-of-way can penetrate high-density residential and commercial areas, traverse city centers and other major activity centers, and allow easy bus and pedestrian access to stations. Access points can be developed simply. Constraining factors include land availability, time to develop, and costs.*

Sometimes busways can be located along active or abandoned rail lines, as in Miami and Pittsburgh (shown in Photo 3-F) and in the case of the proposed New Britain–Hartford Busway. This can reduce land acquisition costs, community impacts, and construction periods. However, right-of-way availability should be balanced with proximity and access to key transit markets. Many rights-of-way are geographically removed from residential and employment concentrations and offer limited opportunities for transit-oriented development.

*Exclusive busways within a freeway corridor may be located either within the median or along one side of the free-*



*Photo 3-F. East (MLK) Busway, Pittsburgh.*

way. Both have the advantages of using existing publicly owned land and operating in reserved lanes and mixed traffic at the outer ends of the busway.

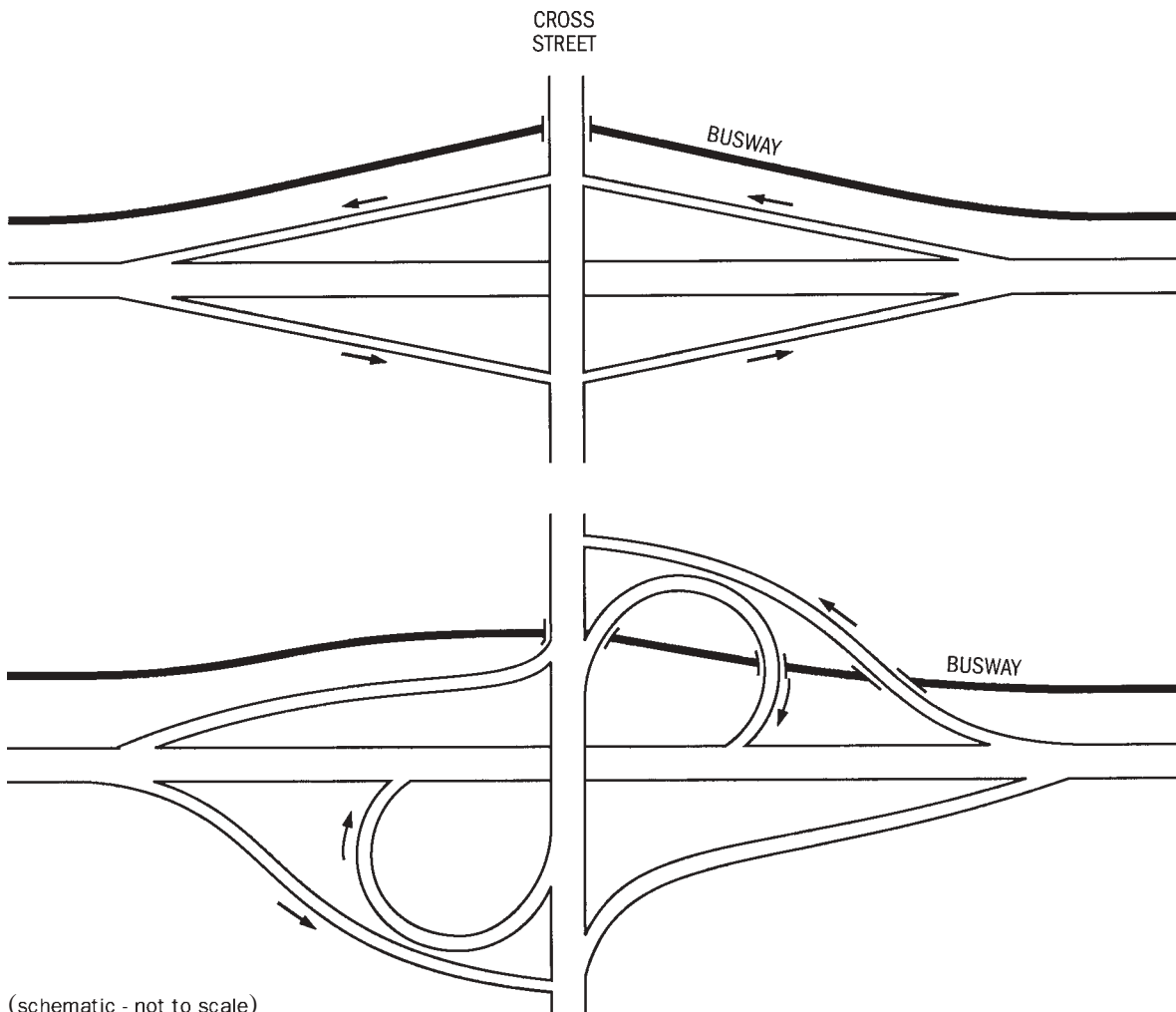
*Busways located along one side of a freeway (such as the South East Busway in Brisbane, shown in Photo 3-G) provide a better identity, easier access to stations, and simplified intermediate and terminal access points; they are also conducive to transit-oriented development along one side, as has occurred in Ottawa.* However, they may require grade separations at freeway interchanges to avoid conflicts with ramps.

When freeway corridors are wide enough, the busway can be located beyond the interchange; when rights-of-way are constrained, the busway may have to be grade separated at all ramps. Examples of possible configurations are shown in Figure 3-18. For diamond interchange configurations, the busway could be located outside of the interchange area; for other configurations, separate structures may be required.

*Busway locations within a freeway median are desirable where freeways are suitably located and costs make it essen-*



Photo 3-G. Busway adjacent to freeway, Brisbane, Australia.



(schematic - not to scale)

Figure 3-18. Busway located alongside freeway at interchange.

tial to minimize rights-of-way. They work best if the majority of demand is to/from a single location (e.g., a CBD), and there are few attractions at intermediate stations. These treatments are relatively simple to achieve, usually involve lower capital costs, and have minimum impact on ramp or interchange geometry. However, complex intermediate bus access points may be needed to avoid weaving across the main freeway lanes. Pedestrian access to stations may be difficult, and direct across-the-platform bus interchange (from BRT to other buses) is not possible. Finally, the identity and image of the busway can be overwhelmed by the freeway, making it difficult to use facility and stations to promote transit-oriented development.

#### 3-3.1.4. Configuration and Operating Concepts

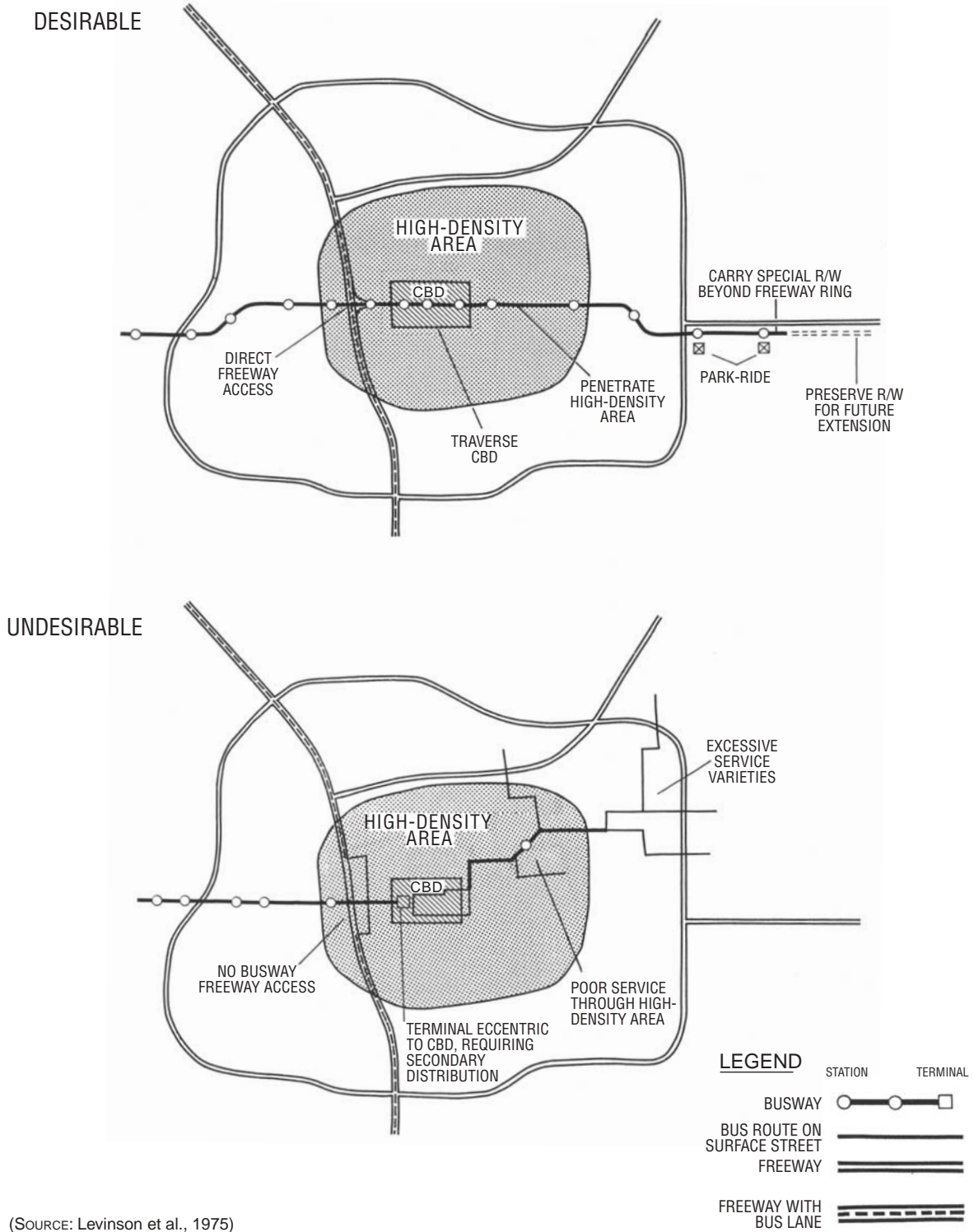
Busways should be straight, penetrate high-density areas, and minimize the number of branches. Figure 3-19 shows desirable and undesirable busway configurations. Some configuration and operating concepts for busways are the following:

1. *Radial Character.* Busways serving a CBD should radiate outward from the city center and ideally pass through it. Cross-town lines should be developed only when clearly warranted by land use and travel densities.
2. *Market Penetration.* Busways should penetrate high-density residential areas and provide convenient downtown distribution. They should serve both high-density (urban) and lower-density (suburban) markets.
3. *Through Service.* Through routes are preferable whenever operating and demand conditions permit. Through service increases passenger convenience and simplifies movements in the city center. However, because of schedule variances, through service may not always be advisable, especially on long routes.
4. *Simplified Route Structure.* Busways should have simple, understandable route patterns. The number of branches should be minimized and be consistent with needs to promote route identity, maintain frequent service, simplify station berthing requirements, and keep dwell times low.
5. *High Operating Speeds.* Portal-to-portal bus speeds between the city center and outlying areas should be comparable to automobile speeds. This can be achieved by providing all-stop and express service along busways. Good geometric design and sufficient distance between stations are important for achieving high operating speeds.
6. *Station Access.* Busway stations should be accessible by foot, bicycle, automobile, or bus. They should be placed at major traffic generators and intersecting bus lines. Park-and-ride facilities should be provided in outlying areas where most access is by automobile. Bicycle locking facilities should be provided where space is available.
7. *Station Spacing.* Station spacing should vary inversely with population density. Close station spacing ( $\frac{1}{4}$  to 1 mile) should be provided where passengers can walk to stations; wider station spacing is feasible where people ride buses to stations ( $\frac{1}{2}$  to 1 mile) or drive to stations (1 to 3 miles). The need for stations is diminished when buses can leave busways for local collection and distribution. To facilitate downtown, off-street, passenger distribution, it is desirable to provide at least three stops at  $\frac{1}{4}$ - to  $\frac{1}{5}$ -mile intervals. This will avoid concentrating all boardings and alightings at one location with attendant increases in bus dwell times.
8. *Convenient Transit, Pedestrian, and Automobile Interchange.* Park-and-ride facilities and, in some cases, bus transfer facilities should be provided in outlying areas where population densities are too low to generate sufficient walk-in patronage.
9. *Maximum Driver Productivity.* The number of peak-hour passengers per bus driver should be maximized through (1) service configurations that allow multiple trips in peak hours, (2) use of high-capacity (e.g., articulated) vehicles, and (3) high speeds.
10. *Downtown Distribution.* BRT service in the city center may be provided by bus streets or bus lanes or in off-street bus tunnels or busways. The goal should be to provide unimpeded through service wherever possible (see Figure 3-20). However, in some cases, terminals can be provided at the edge of the CBD, where walking distances to/from most trip destinations are less than 5 to 10 minutes.

#### 3-3.1.5. Design Criteria and Guidelines

Busway design should permit safe and efficient operation. Some guidelines for busway design are the following:

- Busway designs should enable buses to pass stopped or disabled vehicles without encroaching on the opposite direction whenever possible. This can result in cross sections ranging from 48 to 80 feet at stations including platforms, medians, stopping lanes, and through lanes.
- Busways could be designed for possible future conversion to rail or other fixed guideway transit in terms of horizontal and vertical curves, drainage requirements, and so forth.
- Busways should operate normal flow (with shoulders provided wherever possible), special flow (with a central shoulder or passing lane), or contra flow (with a central shoulder passing lane). Normal flow designs are the simplest and most common. Contra flow configura-



(SOURCE: Levinson et al., 1975)

Figure 3-19. Desirable and undesirable busway configurations.

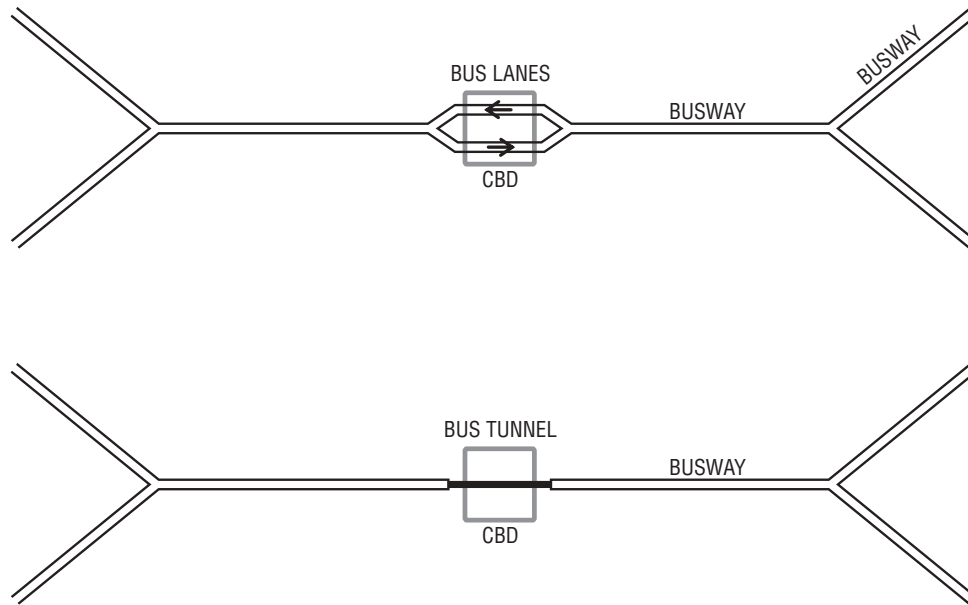


Figure 3-20. Through-service concepts with CBD distribution.

tions permit common center-island station platforms that minimize the number of station stairways, supervision, and maintenance requirements. However, they require crossovers at beginning and end points or vehicles with doors on both sides.

Typical criteria drawn from contemporary highway and busway practice are given in Table 3-8. The criteria are given for two basic types of busways. *Class 1 busways* are completely grade separated and support service levels comparable to rail rapid transit. Examples include Adelaide, Ottawa, and Pittsburgh. *Class 2 busways* are partially grade separated or at grade and support service levels similar to LRT lines. Examples include the South Miami-Dade Busway and the New Britain–Hartford Busway.

**Busway Use.** Transit buses of more than 18 passengers and operated by professional drivers should be allowed to use busways (and contra flow freeway bus lanes). Busways should permit use by emergency vehicles—ambulances, fire trucks, police cars—and by maintenance vehicles.

**Design Vehicle.** Roadway geometry should be governed by the performance and clearance requirements of standard 40- to 45-foot buses and 60- to 70-foot articulated buses. Joint-use guideways should be wide enough to accommodate LRT vehicles.

**Loads.** Structures should be designed to accommodate AASHTO H20-S-16-44 live loads.

**Design Speeds.** Desirable design speeds are 70 miles per hour for Class 1 busways, 50 miles per hour for Class 2

busways, and 40 miles per hour for bus ramps. Minimum design speeds are 50, 40, and 30 miles per hour, respectively. A busway may incorporate sections having different design speeds, but the changes should be few and gradual.

**Alignment.** Safe stopping sight distances, horizontal curvature, and vertical curvature should reflect AASHTO practice. Each is keyed to design speeds. Table 3-8 shows representative values for the mid-range speeds. When future convertibility is a factor, the minimum radius should be at least 250 feet.

**Cross Slopes.** Pavement cross slopes should be between 1.5 and 2%. Slopes on shoulder and border areas can be up to 4 and 6%, respectively.

**Gradients.** Busway grades should be less than 6% when future conversion to rail is anticipated and 9% otherwise.

**Clearances.** Minimum vertical clearances of 13 to 14.5 feet should be provided. Where rail rapid transit is anticipated, vertical clearance will be governed by the future system needs. Lateral clearances (overall) should be at least 6 feet for busways. However, under restricted conditions, minimum 1-foot clearances can be provided along each side of Class 2 busways and along ramps. Center medians, when used, are limited to station areas.

**Envelopes.** Busway envelopes include the travel lanes, center median (if used), shoulders, and outside curbs/parapets along elevated or depressed sections. Many existing Class 1 and Class 2 busways do not use center medians. This has the advantage of allowing passing of a slow or stopped lead-



**TABLE 3-8 Busway design criteria**

DESIGN PARAMETER	CLASS 1 BUSWAY FULLY GRADE SEPARATED	CLASS 2 BUSWAY PARTIALLY GRADE SEPARATED OR AT GRADE
DESIGN SPEED (MPH)	50–70	30–50
ALIGNMENT (MID-VALUES) (FEET)		
Stopping Distance	640	300
Horizontal Curvature	200	125
Desirable Minimum	1350	500
Minimum—Convertible to Rail	250	250
Minimum—Convertible to Light Rail	100	100
Absolute Minimum	100	100
Super Elevation	0.06	0.08
GRADIENTS (%)		
Maximum (Convertible to Rail)	3–4%	3–4%
Maximum	3–5%	4–6%
Minimum	0.3%	0.3%
CLEARANCE (FEET)		
Vertical	14.5 <sup>(a)</sup>	14.5 <sup>(a)</sup>
Lateral (each side)	6	2–6
ENVELOPE (TYPICAL) (FEET)		
Lane Width	13–13.5 <sup>(b)</sup>	11–12
Shoulders	8–10	2–6
Envelope	42–47	26–36
ENVELOPE (SPECIAL) (FEET)		
Elevated	30–36	30
Tunnel (Minimum)	31–32	31–32

NOTES:

<sup>(a)</sup> should be 16 feet where overhead collection (for bus or rail) is planned.

<sup>(b)</sup> 12-foot lanes with 2–3 foot paint separator.

ing bus. These envelopes may vary based on local conditions, although they should be wide enough to permit safe and efficient operation. Envelope requirements are the following:

- Lanes should be 12 feet wide. However, 11-foot lanes are acceptable in constricted areas, at terminals, and along Class 2 busways.
- Shoulders are desirable to accommodate disabled buses and should be provided whenever space permits. Full-width (8- to 10-foot) shoulders are desirable, although narrower shoulders may be used when space is constrained. Shoulders may be reduced or omitted along elevated structures, in tunnels, and in other situations in which right-of-way is limited.

**Pavement Widening on Busway Curves.** Additional lateral width is needed on curves for the maneuvering and overhang of various parts of the buses. Pavements should be widened 1.5 to 2 feet on curves 1,000 feet or less, depending on design speed and busway width (see Table 3-9). These values accommodate a 40-foot-long, 8.5-foot-wide design vehicle, but they will also accommodate a 60-foot articulated bus that requires similar maneuvering space.

**Ramps.** Class 1 busway ramps should be designed for speeds of 30 to 40 miles per hour. Class 2 busways should be designed for speeds of 20 to 30 miles per hour. Lanes should be 12 to 14 feet wide and shoulders should be 10 feet wide. A total width of 22 to 24 feet is desirable, but a total width may

**TABLE 3-9 Pavement widening on two-way, two-lane busway curves**

	ROADWAY WIDTH							
	24 FEET					22 FEET		
	Design Speed, MPH					Design Speed, MPH		
RADIUS	30	40	50	60	70	30	40	
500 feet	1.5	2.0				2.5	3.0	
750 feet	1.0	1.0	1.5			2.0	2.0	
1,000 feet	0.5	1.0	1.0	1.5		1.5	2.0	
2,000 feet	0.0	0.0	0.0	0.5	1.0	1.0	1.0	
3,000 feet	0.0	0.0	0.0	0.0	0.5	0.5	1.0	
4,000 feet	0.0	0.0	0.0	0.0	0.0	0.5	0.5	

NOTE: Values less than 1.5 may be disregarded.

SOURCE: Levinson et al., 1975.

be narrower for limited distances in restricted situations. Ramp exit and entrance speed-change design should follow AASHTO criteria when possible.

3-3.1.5.1. Bus Tunnels

Suitable provisions for tunnel ventilation are essential. Stations may have “conventional” at-curb platforms (high or low level) or may use a transparent wall or door. These transparent doors, which separate the passenger waiting area from the busway lanes and reduce noise levels, open only when the buses arrive. Such doors are used in the downtown Brisbane bus tunnel.

Electric trolley buses and dual mode buses are used in Seattle’s bus tunnel and will be used in Boston’s Silver Line tunnel. Hybrid diesel-electric buses are also being introduced that will allow tunnel operations under battery power. Tunnels for these newer “improved air quality” buses require less ventilation capacity than is required for conventional buses. Vertical clearances should be adequate to accommodate the trolley poles and overhead wires, as appropriate.

Suitable facilities for moving, storing, and passing disabled buses should be provided. This is accomplished by providing a third lane at stations in Seattle’s tunnel and by providing several “storage areas” between opposing directions in Boston’s Silver Line tunnel.

3-3.1.5.2. Sample Cross Sections

Illustrative cross sections are shown in Figures 3-21 and 3-22. Figure 3-21 shows typical busway cross sections for locations between stations. Ideally, two 12-foot lanes should be separated by a 2- to 3-foot painted median and by 8- to 10-foot shoulders. This results in a 42- to 47-foot envelope. Under restricted situations, the center painted median can be

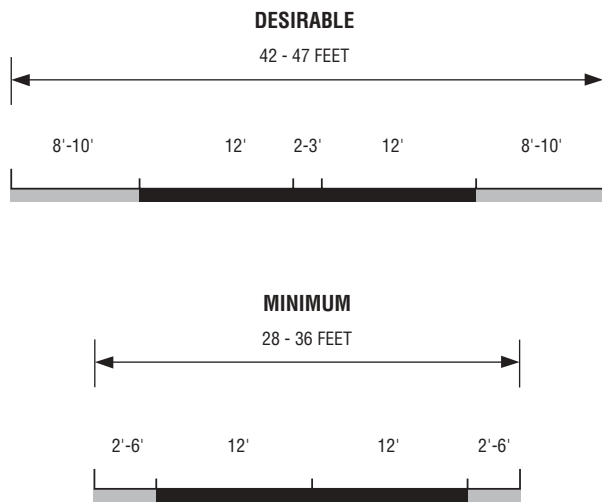


Figure 3-21. Typical busway cross sections.

eliminated, and the shoulders can be reduced to 2 to 6 feet. This results in a 28- to 36-foot envelope. Examples of this busway design are found in Miami, Ottawa, and Pittsburgh. Envelopes at stations are wider to allow passing lanes for buses and facilities for passengers.

Figure 3-22 shows mid-station busway cross sections within a freeway median. In all designs, a barrier median separates the busway from the freeway lanes. The “desirable” treatment shown in Design A provides a 42- to 47-foot envelope, whereas the minimum design, Design B, has 2-foot rather than 8- to 10-foot shoulders and results in a 28-foot envelope. Designs C and D show busway lanes separated by 10-foot and 14-foot painted medians, respectively. Both designs have 2-foot shoulders. The resulting envelopes are 38 to 42 feet. This concept has not been applied in practice.

3-3.1.5.3. Stations

Busways are typically widened at stations to enable express buses to pass buses making stops. Generally, the number of busway lanes is increased from two to four, and the shoulder areas are eliminated. An alternate concept, proposed along the New Britain–Hartford Busway and used on several median arterial busways, provides a single passing lane and staggered station platforms, reducing the overall width (including lanes, medians, and platforms) to roughly 50 feet. Further details on station guidelines are provided in Chapter 5.

3-3.1.5.4. Busway Access

Special access treatments are required where busways begin, end, or branch and where buses enter and leave at intermediate access points. Providing this access is straightforward when busways operate on separate rights-of-way. It becomes more complex when busways are located within freeway medians or alongside freeways. In this case, access can be provided directly onto freeway lanes, or by means of special structures to cross streets.

Busway access options include (1) at-grade slip ramps to freeways, (2) direct ramps to cross streets, (3) flyover ramps, and (4) at-grade, bus-only connections to other busways or streets. In special situations, as in Houston, special “T” ramps from busways in freeway medians to off-line stations can be provided (see Photo 3-H).

Location of access points should reflect street geometry and likely bus routes. Traditional intersection and freeway design standards should be applied per AASHTO and other design and capacity guidelines. Examples of busway freeway connections at the starting and ending points for median and side-aligned busways are shown in Figure 3-23. Transitions to freeway travel lanes are made by high-speed merging and diverging movements. Access to cross streets is by means of a standard “T” ramp.

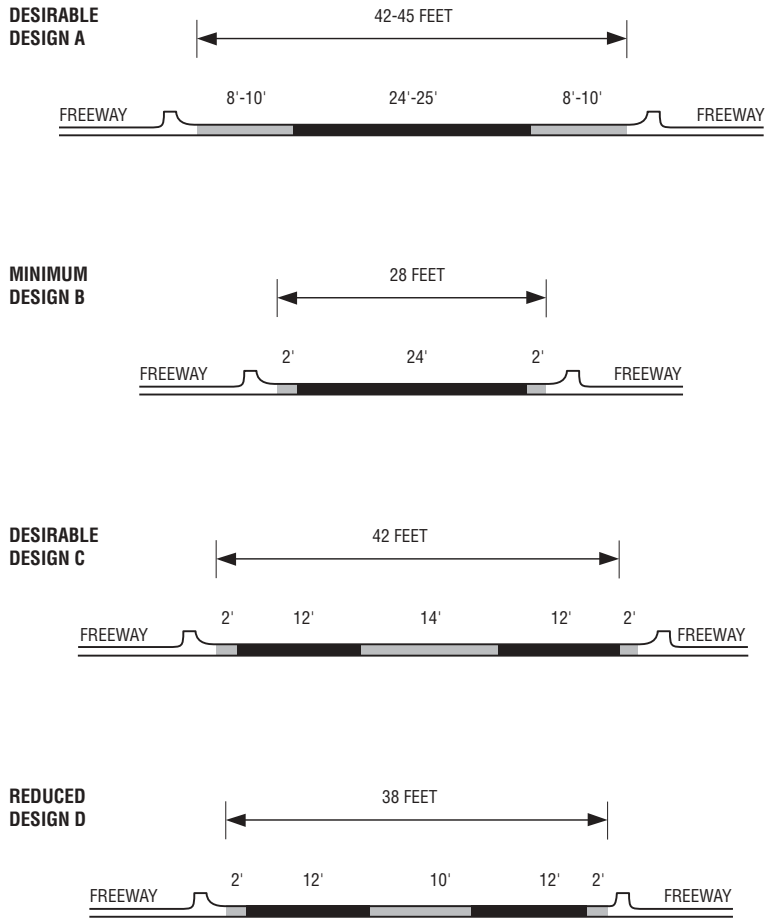
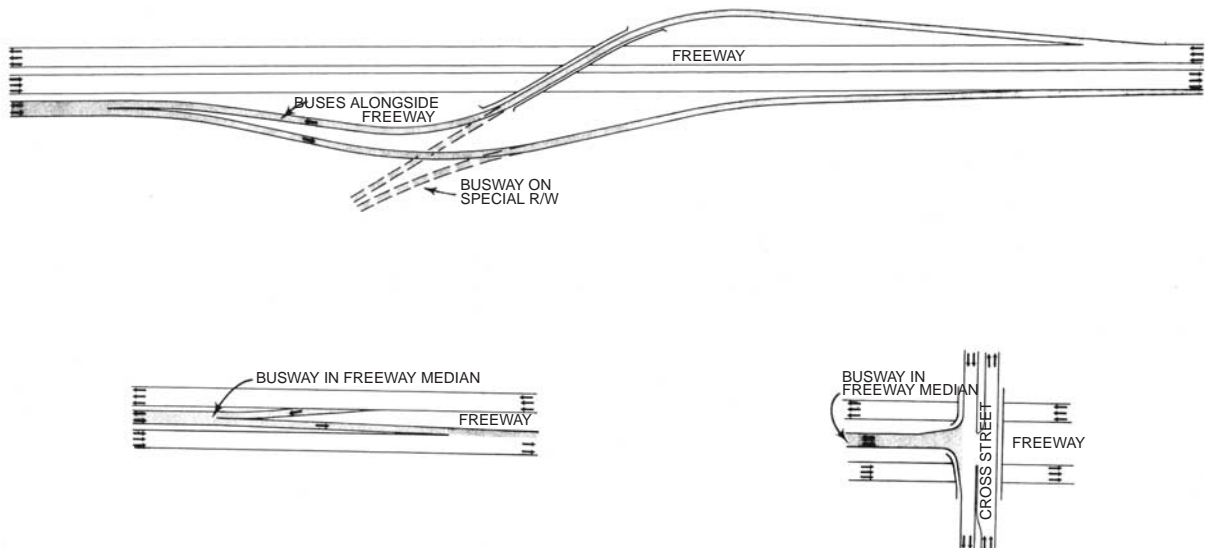


Figure 3-22. Busway cross sections within freeway median.



- NOTES:
1. Minimum outside radius for Busways - 50 ft.
  2. Minimum lane width for Busways:
    - Through Lanes - 12 ft.
    - Left Turn Lanes - 11 ft.

(SOURCE: Levinson et al., 1975)

Figure 3-23. Busway and freeway transitions.



Photo 3-H. “T” ramp in Houston.

Figure 3-24 illustrates busway transition concepts for side-aligned busways connecting with ramps at diamond and partial-cloverleaf interchange ramps. Figure 3-25 provides transition details for busways on their own right-of-way or within the median of a freeway. Figures 3-26 and 3-27 give examples of at-grade bus ramp connections. Generally, a 1-in-50 transition of through lanes around left-turn lanes is required. Stop signs or traffic signals should control movements and give preference to main line busway movements. It is estimated that the at-grade controls can effectively manage bus flows of 3 to 5 buses per minute (180 to 300 buses per hour).

#### 3-3.1.5.5. *Class 2 Busways*

Class 2 busways combine both grade-separated and at-grade intersections. Examples include the South Miami-Dade Busway and the Runcorn Busway. They are similar to arterial median busways except that they should operate on separate rights-of-way. A Class 2 busway concept is shown in Figure 3-28.

Class 2 busways can utilize narrow rights-of-way in urban and suburban areas. When streets and land developments follow rectangular grids, rights-of-way approximately one lot wide can be acquired, and the busways can be developed at grade. Minor streets should terminate in loops or cul-de-sacs, and grade crossings should be signalized.

The busways should be separated from parallel arterial roadways by at least 660 feet. The separation will allow signal controls along intersecting streets to operate independently. Bus-actuated signals at crossing roads should give preferential treatment to buses (advanced green, retarded red cycles); however, this may not be practical when busways intersect heavily traveled crossroads. In such cases, bus actuations should come about in a specified period of the overall background signal cycle.

Class 2 busways also have applicability in new communities and large planned-unit developments. Busways can

penetrate residential developments, with streets and parking located along the outside perimeter. This will reduce walking distance to bus stops and help achieve a synergistic transit-land use relationship.

#### 3-3.1.5.6. *Guided Busways*

Mechanically guided busways operate in Adelaide, Australia; Leeds, United Kingdom; and in Nancy and Caen, France. In Adelaide and Leeds, special guideways provide curbing on each side of single-line “tracks,” and busway track width is sized to fit the distances between three sets of side guidance wheels on each side of the bus. The wheels, which are connected to the power steering system, bear against the concrete curbs. A typical cross-section view is shown in Figure 3-29. The 20-foot section is several feet less than sections required for conventional busways.

Specially fitted standard buses can be used. Their size can vary as long as the horizontal guide wheels are uniformly spaced. Buses can enter the guided busway at 25 miles per hour and operate at a cruising speed of about 60 miles per hour. They can dock precisely at stations. In Nancy and Caen, a central guidance track is contacted by a metal guidance wheel that steers the vehicles.

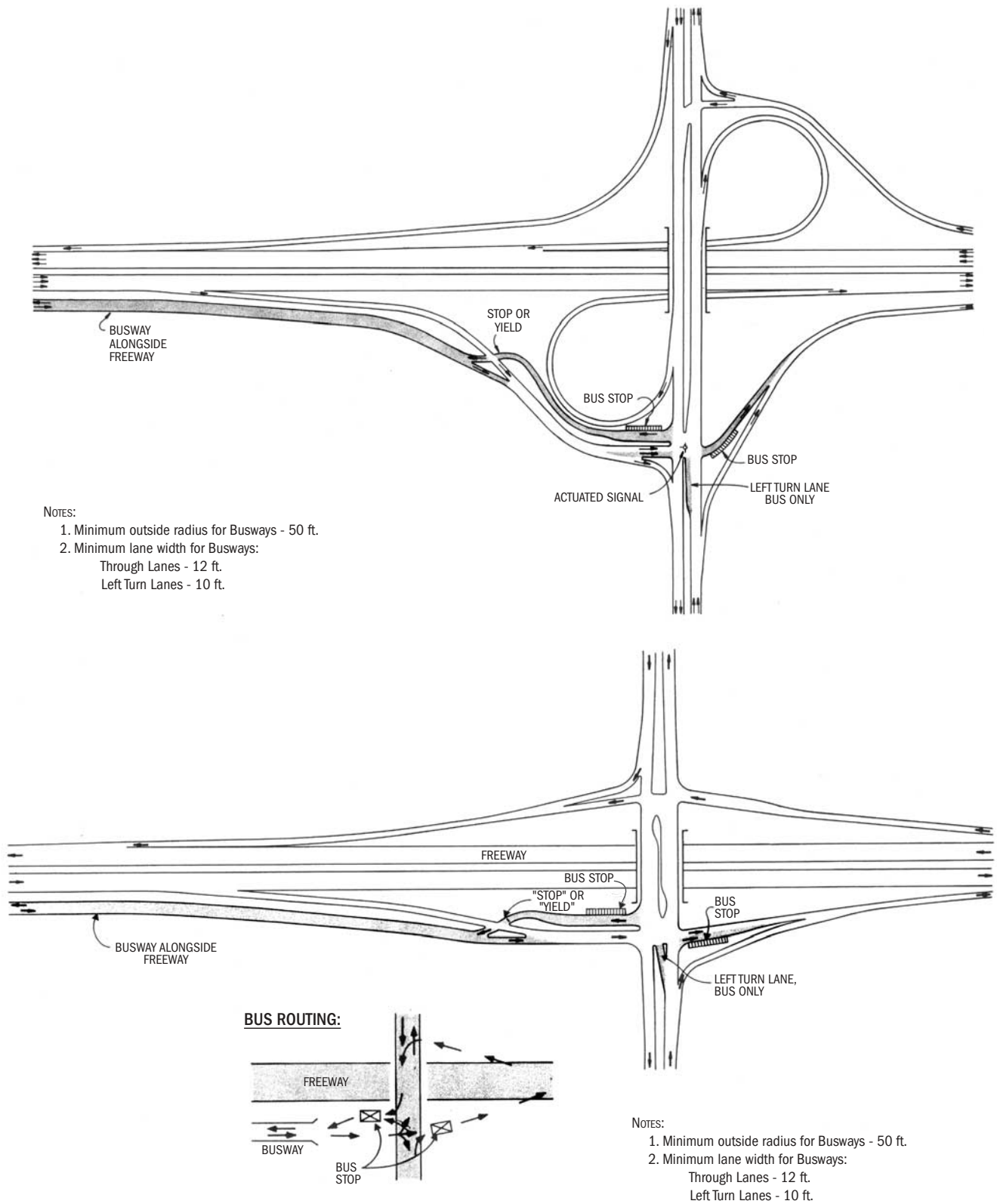
### 3-4. FREEWAY RUNNING WAYS

Freeway running ways can provide a cost-effective basis for BRT. They can speed bus service, improve bus reliability, and also provide a strong sense of identity where stations are provided. They can be used by conventional all-day, high-frequency routes and peak-hour nonstop service, depending on specific facility design and service requirements.

Running way types vary in their placement along the roadway, number of lanes provided, direction of travel, and type of separation. Table 3-10 summarizes the various freeway-related running ways and gives their general applicability for BRT.

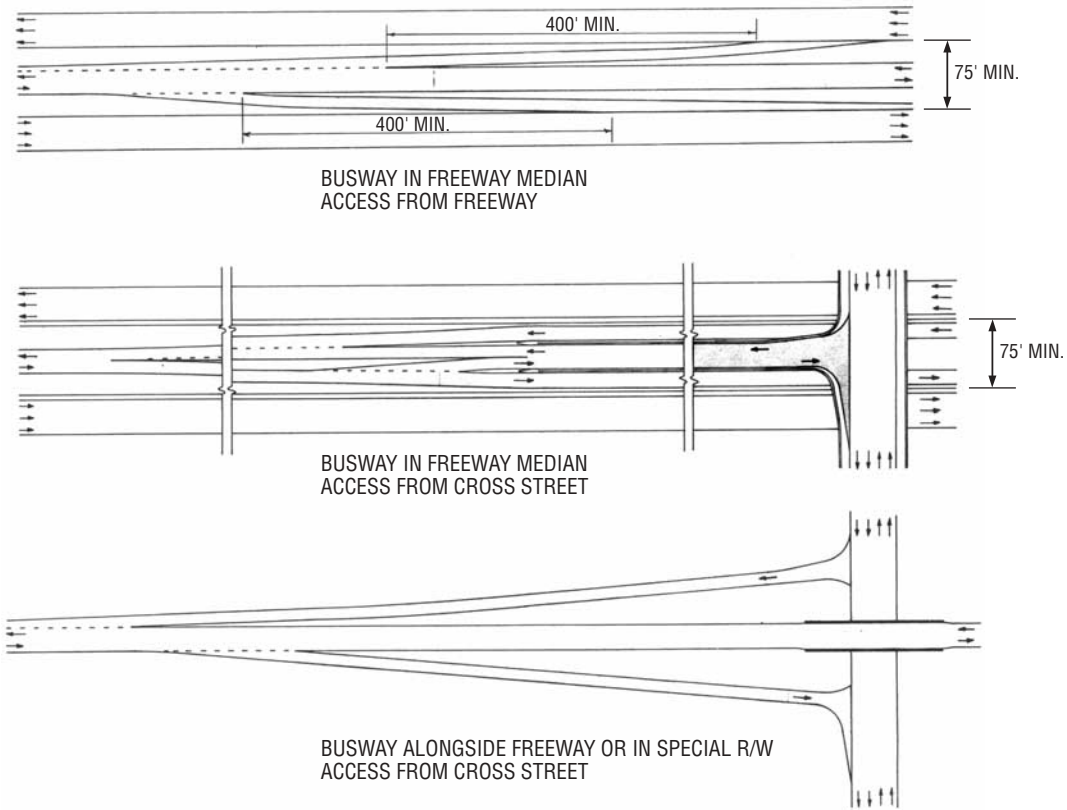
#### 3-4.1. Eligible Vehicles

A major policy decision is whether running ways should be used only by buses or by other HOVs as well. Initial installations in the United States were used only by buses. However, most freeway running ways currently are shared with other HOVs. This practice maximizes throughput in terms of person miles per hour, and it avoids the “empty lane syndrome” in places where bus volumes are low. To avoid impacting the lane’s effectiveness for BRT, a minimum level of service can be specified. For example, whenever the level of service drops below level “C,” the HOV criteria for persons per vehicle can be adjusted or pricing techniques (such as high-



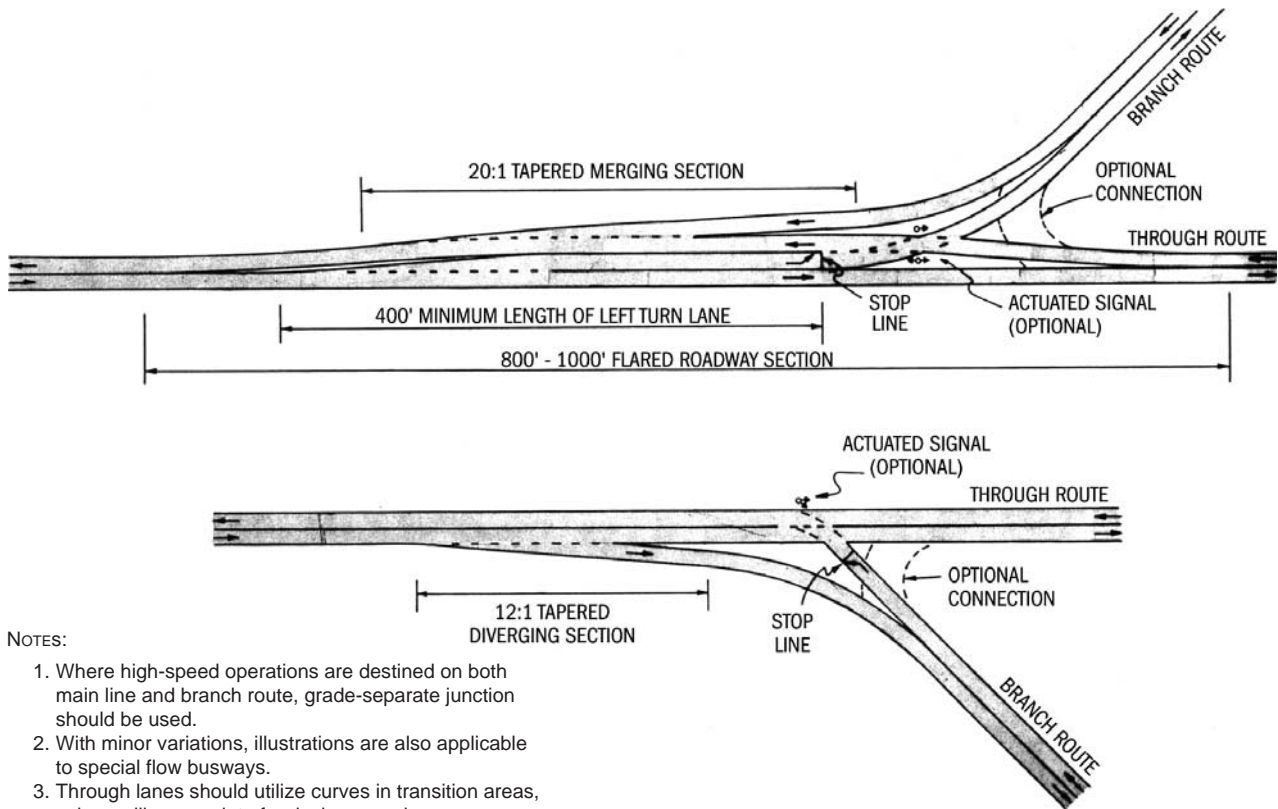
(SOURCE: Levinson et al., 1975)

Figure 3-24. Busway-freeway transitions at interchanges.



(SOURCE: Levinson et al., 1975)

Figure 3-25. Busway access.

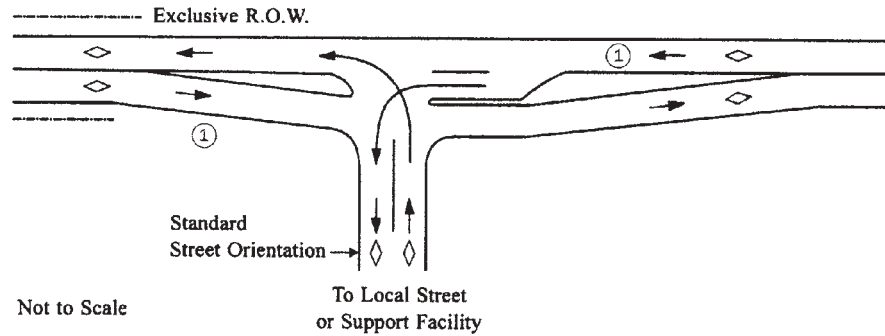


NOTES:

1. Where high-speed operations are destined on both main line and branch route, grade-separated junction should be used.
2. With minor variations, illustrations are also applicable to special flow busways.
3. Through lanes should utilize curves in transition areas, using radii appropriate for design speed.

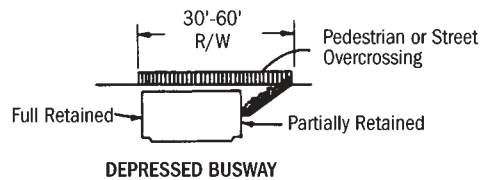
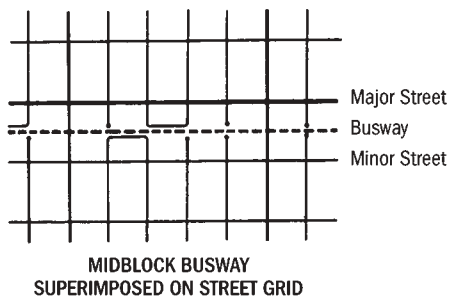
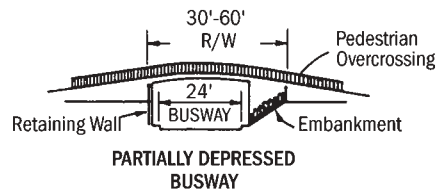
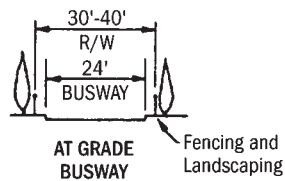
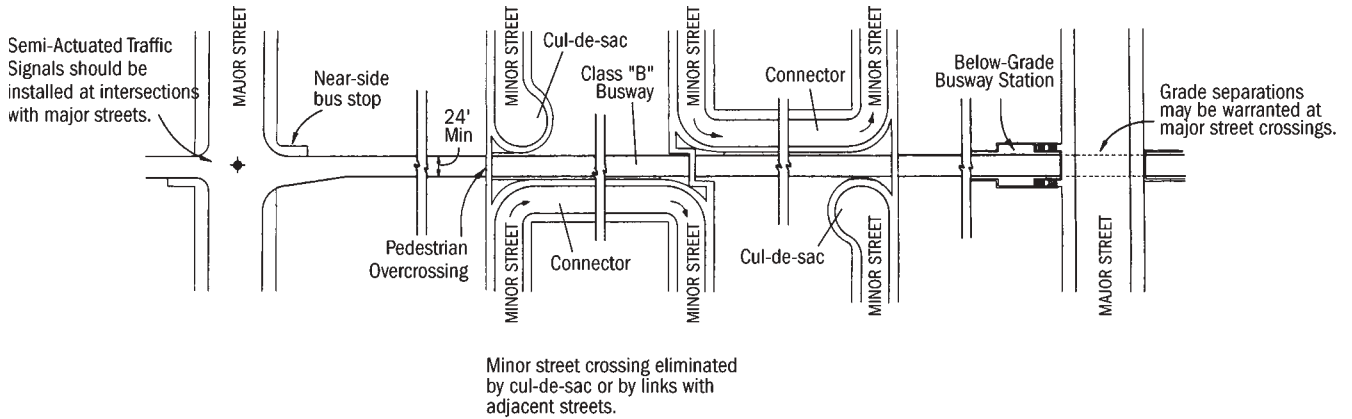
(SOURCE: Levinson et al., 1975)

Figure 3-26. Busway junctions.



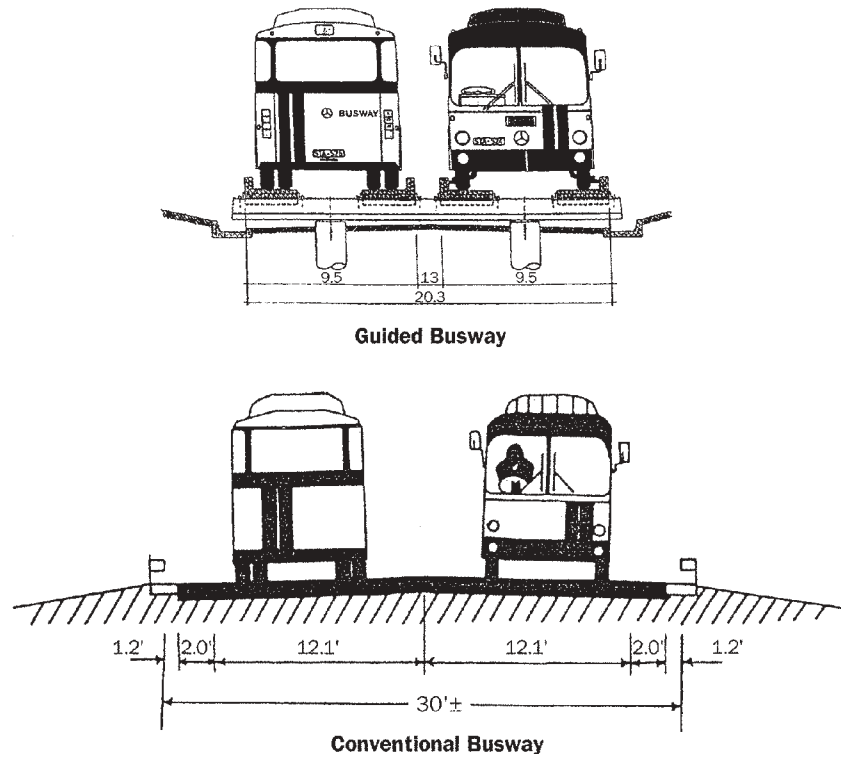
① 1 : 30 taper (minimum)  
 (SOURCE: Levinson et al., 1975)

Figure 3-27. Example of layout for busway intersection.



(SOURCE: Levinson et al., 1975)

Figure 3-28. Class 2 busway concept.



(SOURCE: Richards, 1990)

Figure 3-29. Guided busway and conventional busway sections.

TABLE 3-10 Freeway facility options for BRT

FACILITY	BRT APPLICATION	
	CONVENTIONAL ALL-DAY BRT SERVICE	PEAK-HOUR COMMUTER EXPRESS SERVICE (NO STOPS)
<b>Exclusive Two-Way Facilities (Busways)<sup>1</sup></b>		
Common Shoulder Separation	✓	✓
Physical Barrier Separation	✓	✓
<b>Exclusive Reversible Roadways</b>		
Single Lane		✓
Dual Lanes		✓
<b>Concurrent Flow Bus Lanes</b>		
Right Outside Lane (or Shoulder)	Short sections where interchanges are widely spaced.	
Median Lane		✓
<b>Contra Flow Bus Lanes</b>		
Single Lane		✓
Dual Lanes		✓
<b>Queue Bypass Lanes</b>		
Bus-Only Ramps	Complements other running ways.	
Bus Bypass of Metered Entrance Ramps	Complements other running ways.	

NOTES:

<sup>1</sup> See Section 3-3.1 of this chapter.

SOURCE: Adapted from Texas Transportation Institute et al., 1998.



occupancy/toll lanes) can be considered. Other considerations for bus/HOV shared facilities include the following:

1. Placement of HOV lanes within the freeway may make it difficult to provide on-line stations unless they are considered in the original freeway design,
2. Buses stopping at stations can be delayed when they reenter the HOV lanes, and
3. Reliability may be less certain than with exclusive bus-only running ways.

Where nonstop “commuter express service” is provided (as in Houston), the running ways may be shared with car pools and van pools with off-line BRT stations accessed from the facility with “T” ramps.

### 3-4.2. Planning and Operating Considerations

Planning and operating considerations for running ways are listed below.

**Both median and right-side bus lanes have proven operable.** Median lanes are removed from ramp conflicts at interchanges and can allow special median access to crossroads. However, they require careful design of access points to stations. Right-side lanes allow easy bus entry and exit. However, they result in frequent weaving conflicts, especially where crossroad entry and exit ramps are closely spaced.

**Bus lanes generally should extend at least 5 miles when buses run nonstop to achieve a time savings of 5 miles per hour or more.** The principal exceptions are queue bypass lanes on approaches to major arterial intersections, freeways, or river crossings.

**Existing freeway lanes in the heavy direction of travel should not be converted to bus lanes.** It is better to provide additional lanes so that existing traffic congestion is not worsened.

**Where a BRT commuter service (such as in Houston) operates on an HOV facility, it is essential that the service have its own access/egress ramps to the off-line transit stations and/or its park-and-ride facilities.** Residential collection should be done without requiring buses to weave across general traffic lanes to enter and leave station areas.

**Standardization of freeway entrance and exit ramps to the right of the through traffic lanes permits the use of median lanes by buses either in concurrent (normal) or contra flow traffic.** Dedicated bus entry and exit ramps to and from freeway median bus lanes or roadways should be provided without interfering with normal automobile traffic on the right-hand ramps and requiring buses to weave across the main travel lanes.

### 3-4.3. Design Guidelines

Running way design should be consistent with established standards for the adjacent general purpose freeway. A 70-mile-per-hour design speed is common, although lower speeds are sometimes used. Speeds should also reflect the type of running way. Table 3-11 gives illustrative design speeds for “desirable” and “reduced” conditions.

### 3-4.4. Exclusive Two-Way Facilities

Two-way bus roads (busways) within the freeway median can be physically separated from general purpose traffic lanes by a common shoulder (e.g., the San Bernardino Transitway) or by a physical barrier. They can provide complementary facilities such as stations, bus-bus interchange, and park-and-ride lots.

### 3-4.5. Exclusive Reversible Roadways

Reversible roadways, which are typically separated from freeway lanes by islands or barriers, are provided in several cities for use only by HOVs for peak-period, peak-directional trips. These lanes also can be used for commuter express buses that run nonstop and then leave the lanes via special access points to provide park-and-ride lots with bus service or provide local street distribution service.

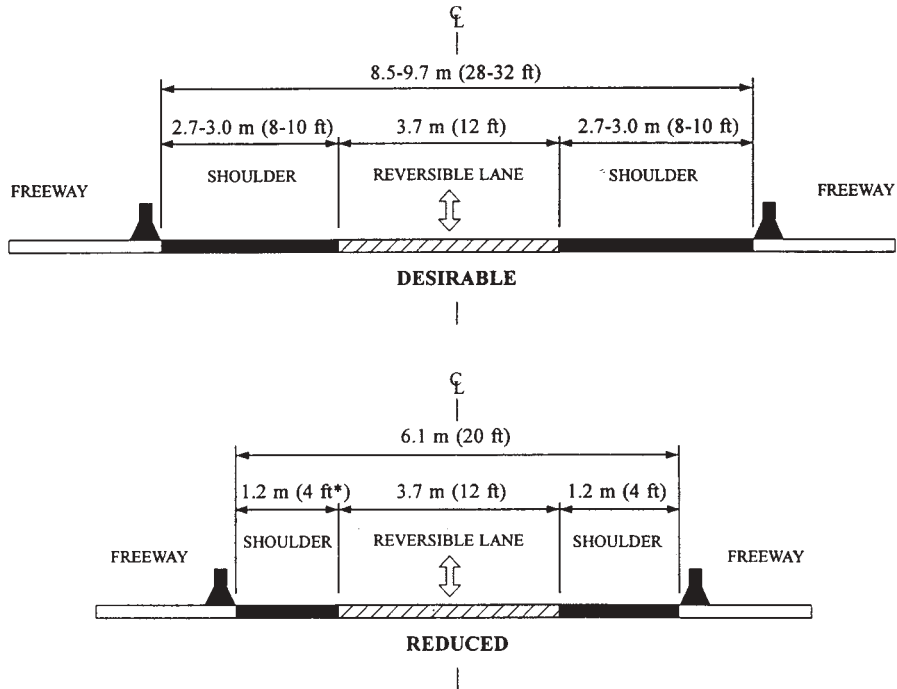
Examples of such facilities include the Shirley Highway in Northern Virginia (I-395), initially a bus-only road; the I-15 Express/high occupancy toll (HOT) lanes in San Diego; and the I-25/HOV lanes in Denver. The largest system is found in Houston where a “Transitway” system that is over 100 miles in length operates in five radial corridors. These exclusive roadways may include intermediate reversible access ramps to streets and park-and-ride lots. Manual and automated methods for opening, reversing, and closing the exclusive roadways are used.

Examples of cross sections are shown in Figure 3-30. A minimum barrier-to-barrier envelope of 20 feet is shown, although this may require adjustments to mirrors to allow for passing capability. A 24- to 28-foot (minimum) envelope to facilitate passing disabled buses is desirable. Figure 3-31 gives an example of the “T” ramps used on the Houston Transitway system. The reversible ramps provide direct access to park-and-ride lots and bus terminals. Key design features include (1) acceleration

TABLE 3-11 Typical design speeds for running ways within freeways

Type of Running Way	Typical Design Speed	
	Reduced	Desirable
Barrier separated	80 km/h (50 mph)	120 km/h (70 mph)
Concurrent flow	80 km/h (50 mph)	100 km/h (60 mph)
Contra flow	40 km/h (30 mph)	80 km/h (50 mph)

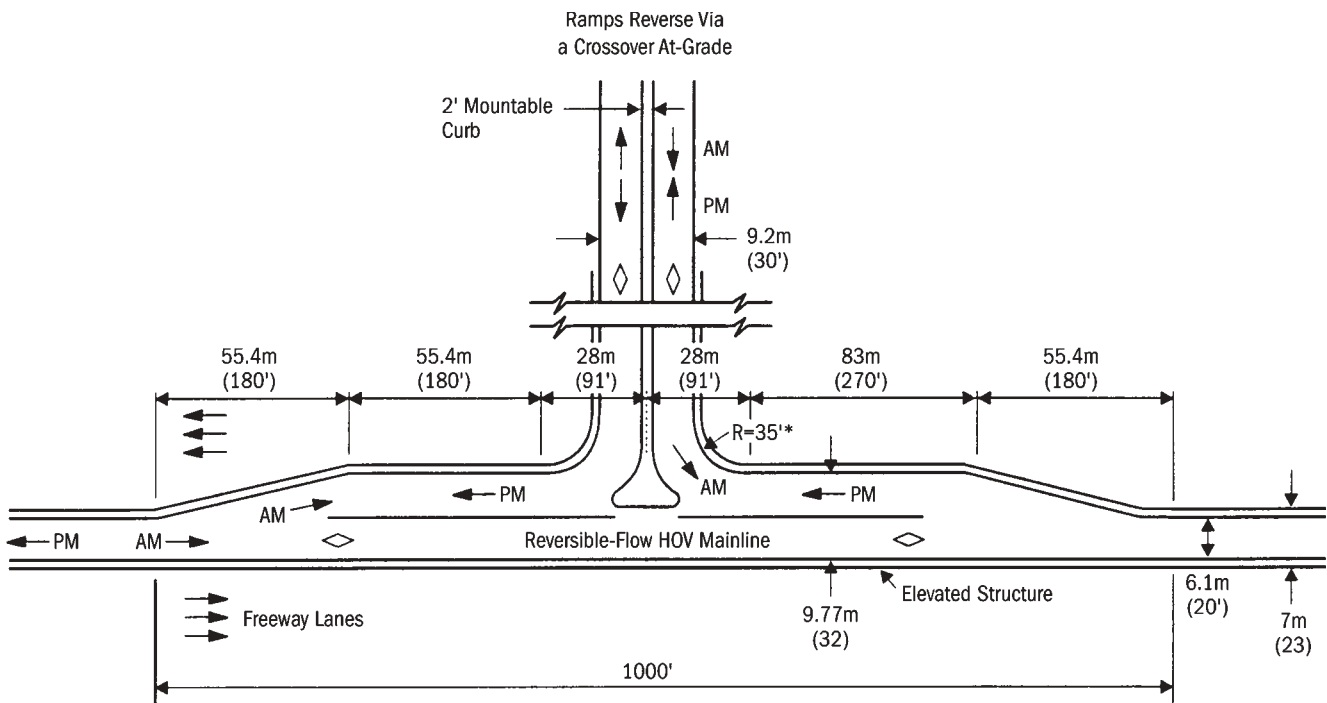
SOURCE: Fuhs, 1990.



\* Lateral clearances may be combined to provide a dedicated 2.4 m (8 ft) shoulder on one side or the other, or a 7.3 m (24 ft) envelope may be striped with two 3.7 m (12 ft) travel ways with traffic always operated to the right of the center stripe

(SOURCE: Texas Transportation Institute et al., 1998)

Figure 3-30. Examples of cross sections for one-lane busway in freeway median.



Not to Scale

(SOURCE: Texas Transportation Institute et al., 1998)

Figure 3-31. Example of reversible flow "T" ramp.

and deceleration lanes where the elevated ramps enter the main HOV roadway and (2) a 22- to 24-foot cross section for the single HOV lane, including a shoulder and travel lane.

The Houston Transitway HOV lanes have several advantages: (1) they make use of available right-of-way within a freeway median; (2) they provide a cost-effective approach to adding peak-direction person capacity; (3) the physically separated lanes are self-enforcing; and (4) a sense of BRT identity can be provided.

Because exclusive reversible roadways permit BRT service only in peak periods, they are best suited for peak-hour commuter express runs rather than for all-day, multi-function BRT.

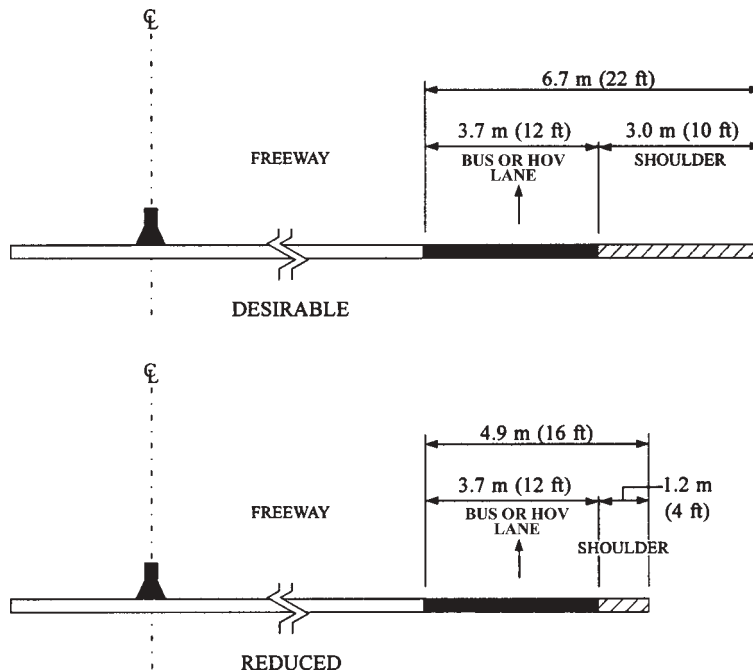
**3-4.6. Concurrent Flow Bus Lanes**

Concurrent flow bus lanes may be located on the outside lanes or shoulders of the main travel lanes or located within the median lane. The outside lanes are appropriate where interchanges are widely spaced, weaving conflicts are manageable, and buses traverse a small number of interchanges. They are used for outlying sections of the Ottawa Transitway, as shown in Photo 3-I. *Median lanes* are the most common HOV treatment. They are removed from entry and exit conflicts, but they require special facilities for bus entry and exit. Like the median barrier BRT options, they include adding lanes to the freeway cross section. The additional lanes may be provided by widening the roadway, narrowing existing lanes slightly, and/or reducing the inside shoulder.



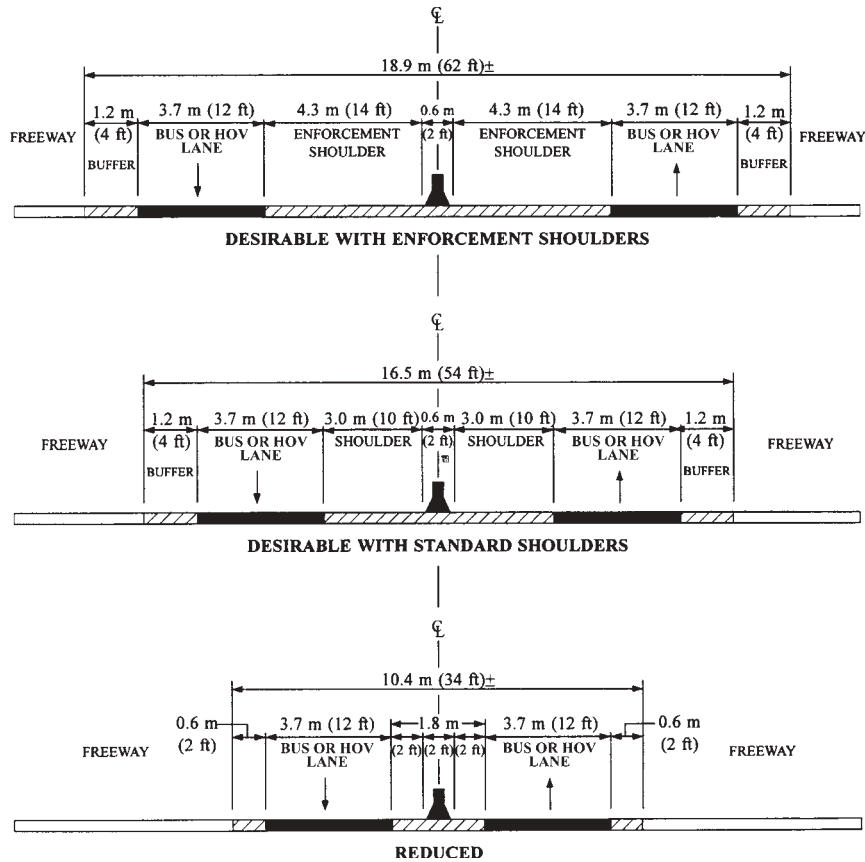
Photo 3-I. Queensway Busway shoulder lane, Ottawa.

Examples of cross sections are shown in Figures 3-32 and 3-33. Lanes should be 12 feet wide with 2- to 10-foot inside shoulders for median lanes and 4- to 10-foot shoulders for outside lanes. Both lane widths and shoulders may be reduced under special circumstances. The lanes are usually separated from the main travel lanes by a solid white lane line that is broken at locations where vehicles may enter or leave. A 1- to



(SOURCE: Texas Transportation Institute et al., 1998)

Figure 3-32. Examples of cross sections for concurrent flow bus (or HOV) lane located on the outside of a freeway.



(SOURCE: Texas Transportation Institute et al., 1998)

Figure 3-33. Examples of cross sections for concurrent flow bus (or HOV) lane located on the inside of a freeway.

4-foot separation from adjacent lanes is desirable where space permits. Normally, entrance to the concurrent flow lanes and exit from them is made from the main travel lanes. These should be located where merging and diverging movements are removed from interchange areas.

Concurrent flow median bus lanes often have advantages of relatively low costs, quick implementation, and minimum right-of-way requirements. However, they are subject to frequent violations and require constant, intensive enforcement to minimize violations—especially when incidents occur in the general purpose lanes. Intermediate, on-line stations at the freeway level or cross-street level could be provided, but they would require sufficient right-of-way width at the cross-street locations. Therefore, their use has mainly been for short nonstop runs (perhaps as links in a more extensive system) or for express bus runs. The BRT identity of the stations could be enhanced by using special colored pavements.

### 3-4.7. Contra Flow Bus Lanes

Contra flow lanes for BRT operate in the off-peak direction of freeways. They are an adaptation of reversible lane

concepts applied to urban freeways for a half century. They are well suited for peak-period express (nonstop) bus runs inbound to the city center in the a.m. peak and outbound in the p.m. peak. Both single and dual contra flow lanes can be provided.

Buses can use single contra flow lanes because (1) the bus lane traffic stream is homogenous, and there is no need for overtaking slower vehicles; (2) buses are highly visible to other drivers, especially when emergency flashers are used; (3) professional bus drivers are generally well trained, experienced, and highly disciplined; and (4) bus lane volumes are relatively low, making the risk of a collision no greater than along an undivided urban arterial or rural highway.

Several a.m. peak-period contra flow lanes operate in the New York–New Jersey metropolitan area. A single bus-only lane has operated on the New Jersey approaches to the Lincoln Tunnel (as shown in Photo 3-J) since 1970. On the Queens approach to the Midtown Tunnel (I-495), a single bus/taxi lane has been operated since 1971. A contra flow bus/HOV lane is provided on the Brooklyn approach to the Brooklyn Battery Tunnel (I-278). Each is heavily used, provides significant travel time saving for bus riders, and has a satisfactory safety record.

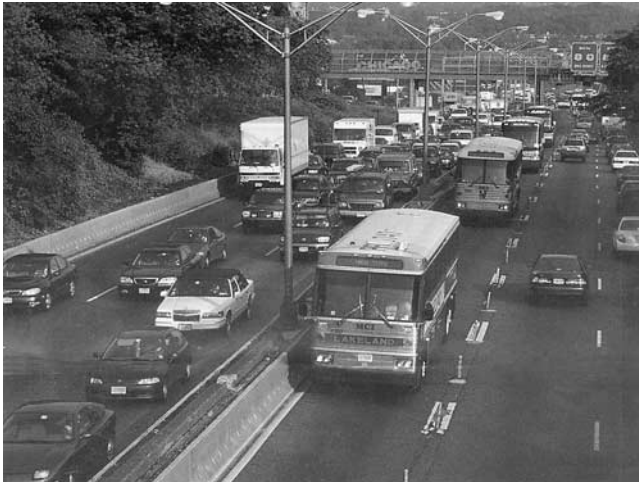


Photo 3-J. Contra flow lane on approach to Lincoln Tunnel, New Jersey.

Contra flow bus lanes are appropriate when (1) there is a high directional imbalance in peak-period traffic, (2) the off-peak direction of travel will not be adversely affected, (3) the freeway is at least six lanes wide, (4) all normal freeway entrances and exits are to the right of the through traffic lanes, (5) the freeway is illuminated, (6) time savings to bus passengers exceed the time losses to traffic in the opposing direction, and (7) there are at least 40 buses per hour.

Examples of cross sections for contra flow lanes are given in Figure 3-34. Ideally, the lanes (and buffer) should be wide

enough to permit buses to pass stalled vehicles (e.g., a 20- to 24-foot envelope), but this is not always practical. Therefore, careful monitoring of operations and provision for quick removal of disabled vehicles are essential.

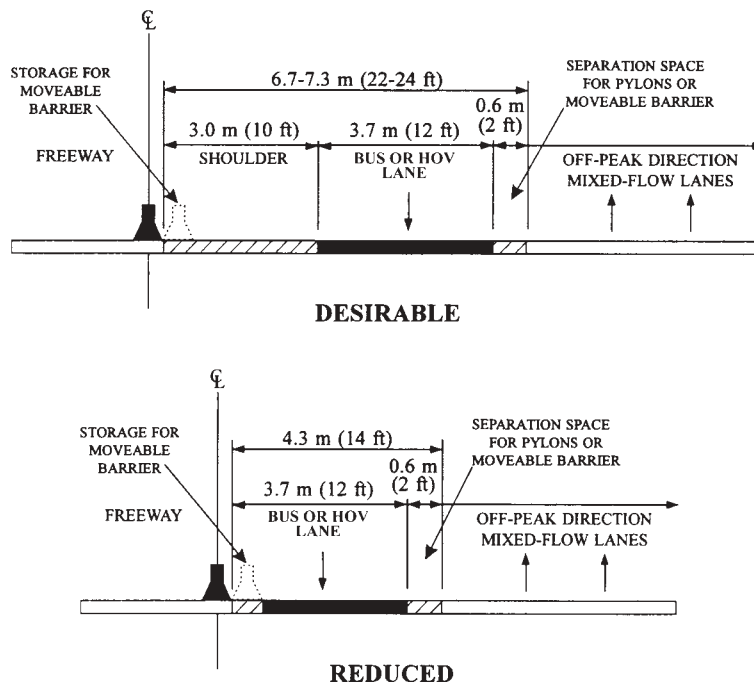
Travel lanes should be 12 feet wide, although 11-foot lanes have also been used. The lanes should have a 2-foot separation from opposing traffic marked by plastic pylons (installed and removed each peak period), as is the case for each of the New York–New Jersey area lanes. Alternatively, the lane separation can be secured by movable barriers, as on the Brooklyn–Battery Tunnel approach, Boston’s Southeast Expressway, and Dallas’s East R.C. Thornton Freeway (I-30 East). Buffer lanes may separate bus and opposing traffic flows in eight-lane freeways when traffic volumes permit.

Illustrative transition treatments are shown in Figure 3-35. A toll plaza provides a natural transition point since speeds are low, and enforcement is relatively simple. Transitions can also be located at (1) the junction of two freeways by providing special bus ramps *before* the points of road convergence and (2) directly from normal freeway lanes.

Ample signing should be provided at transition points and along the bus lanes. Overhead lane-control signals can be placed on special locations and on freeway over-crossing structures.

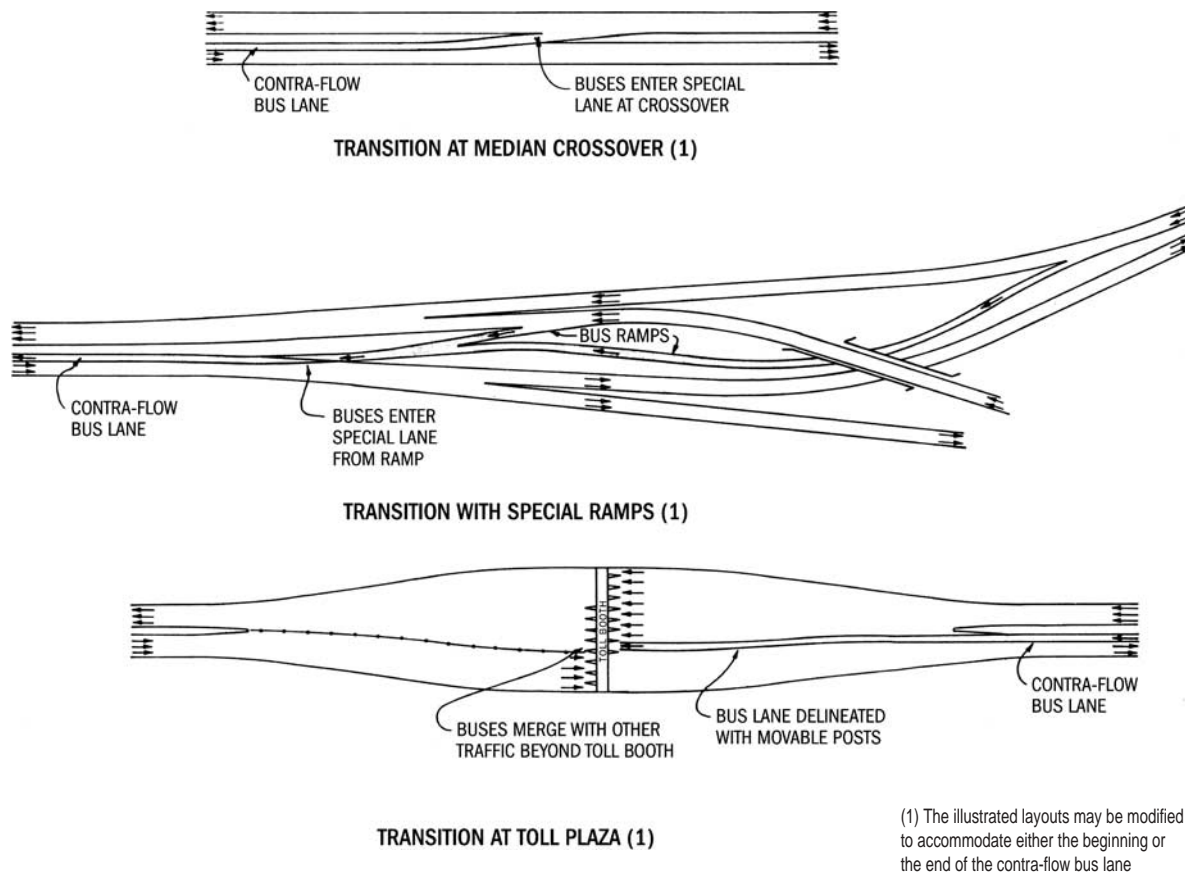
Buses traveling in contra flow lanes should operate with flashers and headlights on to increase visibility to oncoming traffic.

When feasible, contra flow lanes can be installed without increasing the number of freeway lanes. The lanes are free from traffic interferences or violations. Their implementation



(SOURCE: Texas Transportation Institute et al., 1998)

Figure 3-34. Example of cross sections for a contra flow bus lane.



(SOURCE: Levinson et al., 1975)

Figure 3-35. Transition sections for contra flow freeway bus lanes.

costs are relatively low, although their operating costs are higher than for other types of lanes.

Bus access is limited to beginning and end points, and stations cannot be provided. Because the lanes only operate in one direction in each peak period, they do not permit all-day, two-way, multi-function BRT service. Therefore, they are suitable *only* for peak-period commuter express trips or as queue bypasses.

### 3-4.8. Queue Bypass Facilities

Queue bypass lanes at metered freeway entrance ramps and on approaches to toll plazas can expedite bus flow. They are highly selective adjuncts to other BRT running way options. In this context, they can be useful as part of an overall BRT system.

#### 3-4.8.1. Metered Freeway Ramps

Separate lanes (or ramps) at metered freeway ramps can enable buses to bypass queues. Ramp metering with bus bypass lanes is appropriate when (1) freeways are congested with

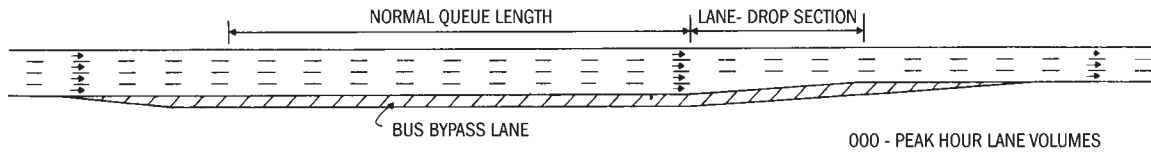
lane densities of 40 to 50 vehicles per mile, (2) ramps can provide adequate storage to minimize spillback onto arterial streets, and (3) parallel surface routes are available.

Illustrative designs for bus bypass lanes at metered ramps are shown in Figure 3-36. Twelve-foot lanes with shoulders are desirable to provide passing of stopped buses; however, narrower lanes without shoulders may be used in restrictive situations. The bus bypass lane can be provided on either side of a metered, mixed-flow lane or as a separate bus-only ramp on the far side (downstream) of a multilane metered ramp. Single lane entrances to the main freeway lanes are desirable.

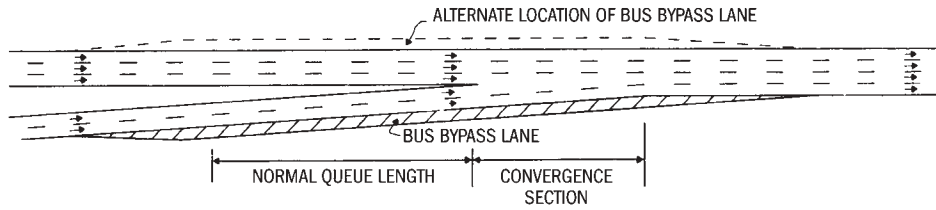
Traffic signal controls should be located a sufficient distance from the freeway merging areas to allow general traffic to accelerate before reaching the freeway lanes. Either pre-timed or traffic-responsive traffic signal controls can be used. Space for enforcement areas is desirable.

#### 3-4.8.2. Bus-Only Ramps

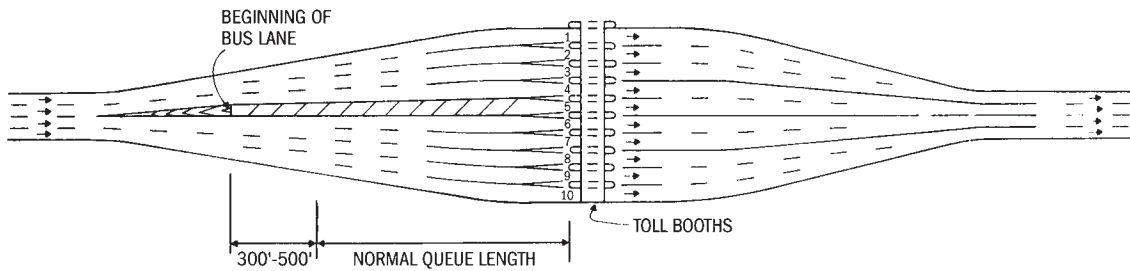
Special bus ramps have been an integral part of the San Francisco–Oakland Bay Bridge and Lincoln Tunnel–Port Authority Bus Terminal express bus operations. These ramps are applicable when they (1) serve facilities with high travel



**LANE DROP**



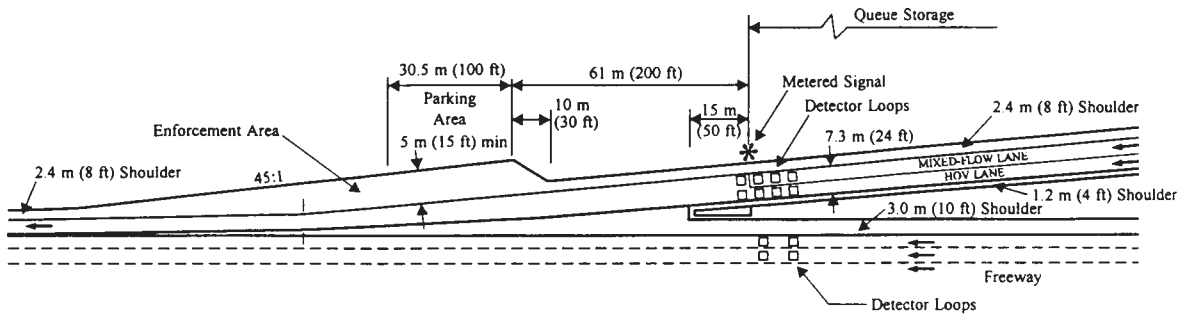
**CONVERGENCE**



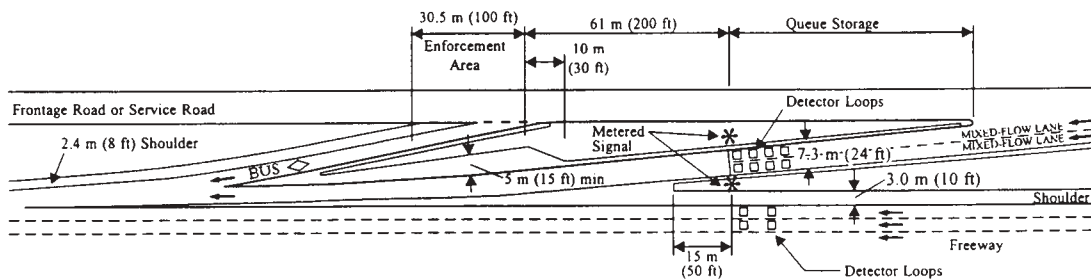
**TOLL PLAZA**

(SOURCE: Texas Transportation Institute et al., 1998)

Figure 3-36. Bus bypass lanes from bottleneck.



**Example of Layout for HOV Bypass Lane at Metered Freeway Entrance Ramp**



**Example of Layout for Separate Bus (or HOV) Ramp on Metered Freeway**

(SOURCE: Levinson et al., 1975)

Figure 3-37. Example of layouts for separate bus (or HOV) ramps on freeway.

demands such as a bus terminal, transfer station, major park-and-ride facility, sports complex, or civic center and (2) provide access that would otherwise be slow, circuitous, or impossible.

Bus ramps can be provided by building exclusive ramps or by converting general purpose ramps to exclusive bus use. The choice will depend on balancing the costs of new ramps against the impacts of automobile-ramp closures on freeway and arterial street traffic operations. Ramp design should provide adequate space to allow passing of disabled buses. This suggests that there should be a single lane with wide shoulders or a two-lane design.

#### 3-4.8.3. Congestion Points and Toll Plazas

Special bypass facilities may be appropriate at toll plazas and points where freeways converge. Queue bypasses are incorporated into several bridge toll plazas across the United States. Examples include the George Washington Bridge in New Jersey, the Coronado Bridge in San Diego, and the San Francisco–Oakland Bay Bridge. The bypass lanes should extend upstream beyond the normal queuing distance. Examples of such bypass lanes are given in Figure 3-37. Bus lanes at toll plazas could pass through the center of the toll plaza or could be located at the far right side of the plaza.

### 3-5. CHAPTER 3 REFERENCES

*A Policy on Geometric Design of Highways and Streets—2001.* American Association of State Highway and Transportation Officials, Washington, DC (2001).

*Bus Rapid Transit Options in Densely Developed Areas.* Wilbur Smith and Associates, U.S. Department of Transportation (February 1975).

*Design Criteria for Metro Park and Ride and Transit Center Facilities.* Metropolitan Transportation Authority, Houston, TX (2002).

Fitzpatrick, K., K. M. Hall, S. Farnsworth, and M. D. Finley. *TCRP Report 65: Evaluation of Bus Bulbs.* Transportation Research Board, National Research Council, Washington DC (2001).

Fuhs, C. A. *High-Occupancy Vehicle Facilities: A Planning, Design, and Operation Manual.* Parsons Brinckerhoff Quade & Douglas, Inc., New York, NY (1990).

Gardner, G. P., P. R. Cornwell, and J. Cracknell. *The Performance of Busway Transit in Developing Cities.* Transport and Road Research Laboratory, Drawthorne, Berkshire, United Kingdom (1991).

*Guide for the Design of High-Occupancy Vehicle Facilities.* American Association of State Highway and Transportation Officials, Washington, DC (2001).

Levinson, H. S., C. L. Adams, and W. F. Hoey. *NCHRP Report 155: Bus Use of Highways: Planning and Design Guidelines.* Transportation Research Board, National Research Council, Washington DC (1975).

Levinson, H., S. Zimmerman, J. Clinger, S. Rutherford, R. L. Smith, J. Cracknell, and R. Soberman. *TCRP Report 90: Bus Rapid Transit, Volume 1: Case Studies in Bus Rapid Transit.* Transportation Research Board of the National Academies, Washington, DC (2003).

Parsons Brinckerhoff Quade & Douglas. “NCHRP Project 20-7 (Task 135): Geometric Design Guide for Transit Facilities on Highways and Streets—Phase I Interim Guide.” Transportation Research Board, National Research Council, Washington DC (2002).

Richards, B. *Transport in Cities.* Architecture Design and Technology Press, London, United Kingdom (1990).

St. Jacques, K., and H. S. Levinson. *TCRP Report 26: Operational Analysis of Bus Lanes on Arterials.* Transportation Research Board, National Research Council, Washington, DC (1997).

Texas Transportation Institute, Parsons Brinckerhoff Quade & Douglas, and Pacific Rim Resources, Inc. *NCHRP Report 414: HOV Systems Manual.* Transportation Research Board, National Research Council, Washington DC (1998).



## CHAPTER 4

# TRAFFIC ENGINEERING FOR BRT

Traffic-transit operations integration is an essential component of the planning design and operation of BRT running ways. Close working relationships between traffic engineers and transit planners is essential in developing bus lane and busway designs, locating bus stops, and applying traffic controls.

A good program of traffic controls and signage should help ensure safe vehicle and pedestrian crossings of bus lanes and busways and minimize delays to BRT vehicles and general traffic. Good traffic controls and signage will maintain essential access to curbside activities and provide a reasonable allocation of street space among competing uses—BRT, other buses, and curbside access for general traffic and pedestrians. The program of traffic controls and signage should be perceived as reasonable by bus passengers, motorists, and abutting land users. An effective enforcement program is essential. This chapter provides traffic engineering guidelines for the various types of running ways. Further details can be found in the Institute of Transportation Engineers *Traffic Engineering Handbook* (Pline, 1999).

### 4-1. OVERVIEW

The specific traffic engineering techniques vary with the type and location of BRT running ways. These techniques can be grouped in four basic categories: (1) traffic controls, (2) special signs and signal displays, (3) traffic signal controls and priorities, and (4) enforcement. Applications of these techniques are shown in Table 4-1. The techniques are mainly applicable to street-running BRT, but they also apply wherever busways or freeway bus lanes interface with roads and streets, such as at intersections.

The techniques include (1) controls for curb parking, left turns, right turns, and one-way streets; (2) special signage and traffic signal displays; and (3) traffic signal controls, including BRT preference and priority. Additional techniques include curb adjustments, changes in roadway geometry, and pavement markings. Some general guidelines are as follows:

- Stop signs or traffic signals should be placed on streets that intersect BRT routes.
- Curb parking (all day or during rush hours) should generally be restricted along BRT running ways.

- Left and right turns should be restricted when they cannot be accommodated without delaying BRT.
- Special signage should define BRT running ways and inform motorists of at-grade busway crossings.
- Special BRT traffic signal indicators should be provided to minimize motorist confusion, especially along median arterial busways and at queue jumps.
- Red times (and hence delays) for buses should be kept to a minimum. This can be achieved by (1) maximizing the available green time, (2) using as short a traffic signal cycle length as possible, and/or (3) appropriately advancing and extending green time as BRT vehicles approach intersections.
- ITS technologies can enhance and better integrate traffic engineering and control measures. This is described more fully in Chapter 7.

### 4-2. TRAFFIC CONTROLS

Traffic controls relating to curb use, turning movements, and street directions can be applied at individual locations, on selected segments, or on an entire BRT route.

#### 4-2.1. Curb Parking and Loading Controls

Curb parking problems are especially acute in older parts of urban areas where activities are clustered and off-street parking space is limited. Curb parking problems are a major concern within central areas, outlying business districts, and along streets lined with shops and offices. These are often corridors with good BRT market potential, which are served by BRT running ways.

Curb parking reduces the space available for buses and automobiles, conflicts with movement in adjacent lanes, reduces bus and automobile speeds, and increases accidents. Parking prohibitions where there are major bus facilities have reduced accidents by about 15 to 20% and have increased travel speeds for all vehicles. Accordingly, there should be no parking along BRT routes in congested areas and along heavily traveled arteries, at least during rush hours. However, parking can be retained along streets with “interior,” or median, bus lanes or along lightly traveled streets where bus bulbs are provided for passenger convenience.

**TABLE 4-1 Typical BRT applications of traffic engineering techniques**

Type of Running Way	Traffic Controls				Special Signs and Signal Displays		Traffic Signal Controls and Priorities		Enforcement
	Curb Parking Restrictions	Right-Turn Restrictions	Left-Turn Restrictions	One-Way Streets	Signs	Signals	Passive Priority	Active Priority	
Busways									
Tunnels									✓
Grade Separated					✓		✓ <sup>a</sup>	✓ <sup>a</sup>	✓
At grade					✓ <sup>b</sup>	✓	✓	✓	✓
Freeway Lanes									
Concurrent Flow					✓				
Contra Flow					✓				
Bus-Only Ramps					✓				
Priority at Metered Ramps					✓		✓		
Arterial Streets									
Median Arterial Busway			✓ <sup>c</sup>		✓	✓	✓ <sup>c</sup>	✓ <sup>c</sup>	✓
Curb Bus Lanes	✓	✓	✓	✓	✓		✓	✓	✓
Dual Curb Lanes	✓	✓	✓	✓	✓		✓	✓	✓
Interior Bus Lanes		✓	✓	✓	✓		✓	✓	✓
Median Bus Lanes			✓		✓		✓	✓	✓
Contra Flow Lanes	✓		✓	✓					
Bus-Only Street	✓			✓	✓	✓	✓	✓	✓
Mixed Traffic Flow	✓	✓	✓	✓			✓	✓	✓
Queue Bypass				✓	✓	✓	✓	✓	✓

NOTES:

<sup>a</sup> Only at busway access points.

<sup>b</sup> On both busways and cross streets.

<sup>c</sup> Special left-turn phasing where left turns are permitted.

Curb parking can be prohibited at all times or just during rush hours. When BRT uses curb bus lanes throughout the day, it is possible to use distinctively colored pavements to identify the lanes. As a general rule, curb parking should be prohibited during busy traffic periods when traffic volumes exceed 500 to 600 vehicles per lane per hour; the street operates at “Level of Service” E or F, automobile speeds fall below 20 to 25 miles per hour, and the lane is needed for bus or BRT use. Off-street loading areas are desirable along BRT routes.

**4-2.2. Turn Controls**

Left and right turns can seriously impede BRT and general traffic flow at many locations. The “right-turn problem” is usually critical in areas of heavy pedestrian activity with both narrow corner radii and major pedestrian crossings (e.g., often where stations are located.) These conditions usually are found in the city center and older high-density neighborhoods. Left turns, however, create problems throughout the street system. They not only conflict with opposing through traffic, but they also may block the vehicles behind them and complicate traffic signal phasing.

Because of problems with left and right turns, left- and right-turn restrictions are used in many urban areas to preserve capacity and to reduce congestion. The controls may be in effect all day, from 7 a.m. to 7 p.m., or during rush hours only. From a BRT perspective, these controls are desirable. The general principle is that when turns create problems,

they should be prohibited. At places where BRT and other bus routes turn from one street to another, the buses generally should be exempted from any turn restrictions. Many communities provide such exemptions.

*4-2.2.1. Right Turns*

Right-turn restrictions may be appropriate at locations where BRT operates in mixed traffic, curb bus lanes, or “interior” bus lanes and where both right turns and pedestrian volumes are heavy. Each pedestrian per channel takes a specified time to cross the area in which there is conflict with right turns; in effect, each pedestrian delays each right turn by this time. The time lost can be estimated by weighting the time per pedestrian by the number of pedestrians and right turns per signal cycle. The travel times gained by restricting right turns can then be approximated from the following equation:

$$\Delta t = \frac{r p t_s}{L}$$

Where

- $\Delta t$  = green time to be gained per cycle,
- $r$  = right turns/cycle (peak 15 minutes),
- $p$  = conflicting pedestrians/cycle (peak 15 minutes),
- $t_s$  = time per pedestrian (e.g., 3 to 4 seconds), and
- $L$  = number of pedestrian channels in crosswalk (e.g., 1 to 4).

**TABLE 4-2 Estimated time lost per cycle by conflicting right turns and pedestrian volumes**

Typical Values of $R/N_c$ and $P/N_c$	Time Loss per Cycle at 3 seconds per Pedestrian Channels (lanes)			
	1 Lane	2 Lanes	3 Lanes	4 Lanes
4	12	6	4	3
8	24	12	8	6
12	36	18	12	9
16	48	24	16	12
20	60	30	20	15
24	72*	36	24	18

**NOTES:**

For a 60-second cycle, time loss should not exceed 25% of cycle or 15 seconds. Thus, values below the boldface lines are not acceptable, and turns should be prohibited.

\* = excess cycle length

$R$  = right turns per hour

$N_c$  = number of cycles per hour

$P$  = pedestrians per hour

Estimated time lost per signal cycle by conflicting right turns and pedestrian volumes is shown in Table 4-2. For example, if there were 300 pedestrians per hour conflicting with 240 right turns per hour (5 and 4 per cycle), and 3 seconds lost per conflict, about 20 seconds per cycle would be lost, assuming 3 pedestrian channels. If the turns were prohibited, the curb lane would then gain an additional 20 seconds of effective green time. Thus, to ensure a minimum effective green time of 25% of the cycle, it would be necessary to prohibit the right turns in this case.

#### 4-2.2.2. Left Turns

Left turns at intersections along BRT routes may be permitted when protected left-turn lanes are provided. In some cases, special signal phases for the turns may be necessary. However, left turns generally should be prohibited when the turns share lanes with through traffic. Shared lanes cut lane capacity by about 50%, delay through vehicles, and increase accidents. One left turn per signal cycle delays 40% of the through vehicles in the shared lane.

When BRT operates in median arterial busways, it is essential to either prohibit left turns from the parallel roadways or to provide protected signal phases for the turns. Protected signal phasing is also essential when there are multiple left-turn lanes. When street patterns permit and there are alternative street routings, prohibition of left turns along BRT routes is desirable. The prohibition will simplify traffic signal phasing, reduce queues, and improve both bus and general traffic flow. On a 1-mile trip that takes 4 minutes (15 miles per hour), about 0.5 minutes are lost because of left-turn delays. With the turns prohibited, the trip takes 3.5 minutes, a savings of 12.5%.

There are other ways to accommodate left turns, including far-side “Michigan U-Turns” and “Jersey Jug Handles.” Both of these strategies convert left turns into right turns. If

space permits, these strategies for accommodating left turns should be explored.

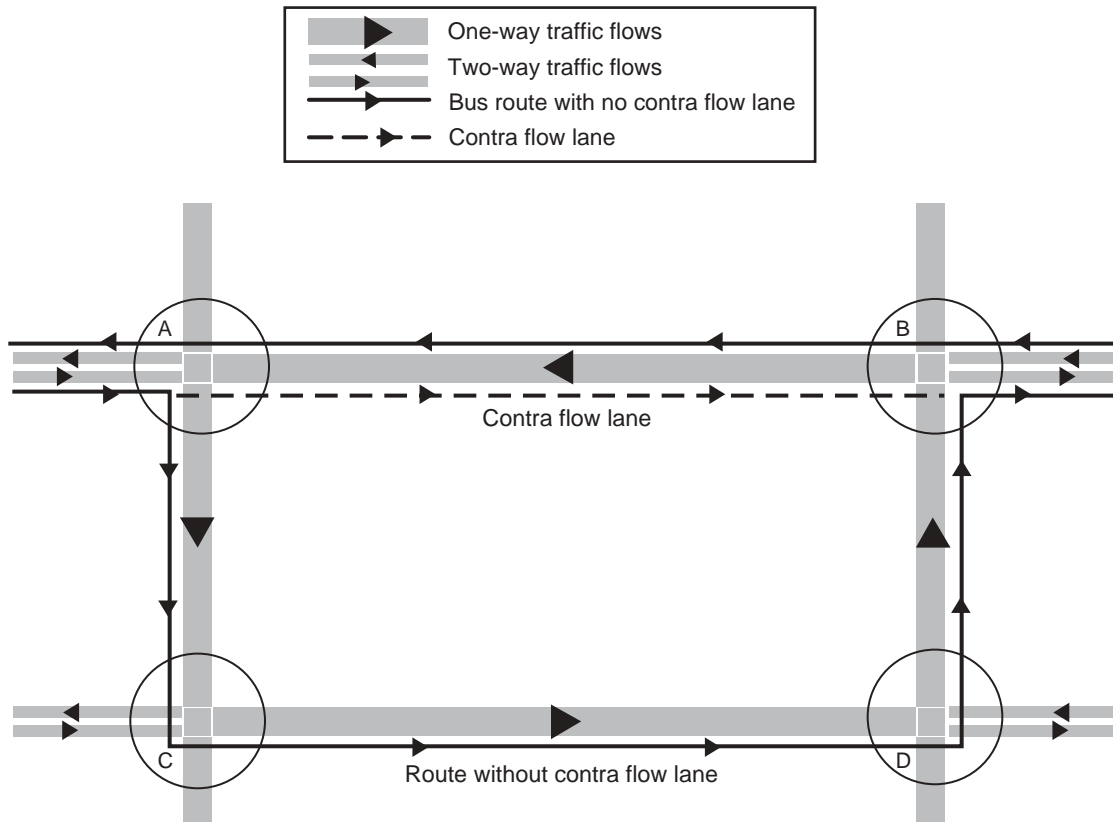
#### 4-2.3. One-Way Streets

One-way streets can facilitate bus, automobile, and truck flow. Traffic moves in one direction, thereby reducing conflicts and crashes, simplifying traffic signal phasing, and improving traffic signal progression. The benefits of one-way streets in improving safety and traffic flow have been well documented. Travel time reductions of about 25% are common, capacity may be increased by 20 to 40%, and accidents can be reduced by 10 to 50%. Thus, one-way streets can improve BRT speed and reliability in both mixed traffic and in bus lanes. With wide spacing between bus stops, buses can keep up with the signal progression, especially where dwell times at stops are low. One-way streets are essential in downtown street grids with narrow and closely spaced blocks.

There are, however, several disadvantages to one-way streets from a BRT perspective. These disadvantages include the following:

- BRT service is divided into two parallel streets with attendant losses in BRT identity.
- The streets may preclude curbside passenger access when activities are located between the two one-way streets.
- When activities are concentrated along one street, passenger walking distances are increased.
- The number of curb faces where buses can pick up or discharge passengers could be cut in half.

Sometimes, these concerns can be overcome by running buses two ways on one of the streets (e.g., one direction in a contra flow lane). Figure 4-1 shows how a contra flow bus lane can be used to keep buses going two ways on a central area one-way street grid. Buses are able to (1) eliminate three



(SOURCE: Webster and Bly, 1976)

Figure 4-1. Hypothetical network for one-way streets.

turns, (2) reduce bus mileage, and (3) maximize the presence of buses on a single street.

**4-3. SPECIAL SIGNAGE AND SIGNAL DISPLAYS**

Special signage and traffic signal displays are desirable along BRT routes. They should be installed in general accord with the provisions of the *Manual of Uniform Traffic Control Devices for Streets and Highways, Millennium Edition* (MUTCD) (2001).

**4-3.1. Traffic Signs**

Standard diamond signs, used for bus and HOV lanes, should be used for BRT running ways. As indicated in Chapter 4 of the MUTCD, they can be placed over the lanes or be mounted along the side of the roadway (2001). Their spacing should be based on engineering judgment that considers prevailing speeds, block lengths, and distances from adjacent intersections.

Guidelines for the application of regulatory and warning signs for highway traffic at LRT crossings are given in Chapter 10 of the MUTCD (2001). These signs could be adapted for use at intersections along at-grade busways on private rights-of-way or in street medians.

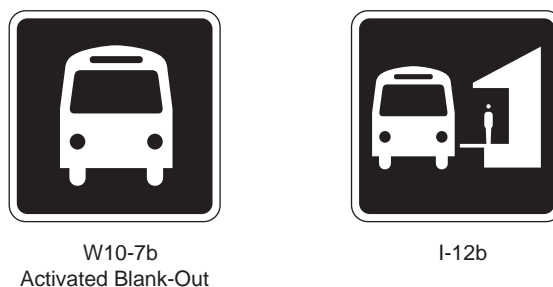
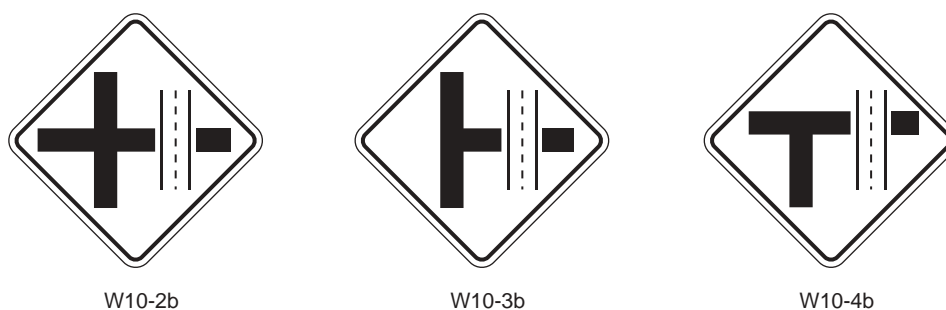
Examples of these signs are provided in Figures 4-2a and 4-2b. The symbols and wording have been modified to depict buses and busways instead of LRT vehicles and tracks. Their application should be generally consistent with applications set forth in the MUTCD.

**4-3.2. Signal Displays**

Traffic signal displays and locations should be consistent with those set forth in the MUTCD as well as those specified by local agencies. The “Transit Signal” displays for LRT vehicles should be used for BRT, as appropriate. They are applicable where buses operate (1) along median arterial busways, (2) along at-grade busways on separate rights-of-way, and (3) in queue bypass lanes. The rationale is that BRT vehicles are, in essence, rubber-tired LRT vehicles. Examples of these signal displays are shown in Figure 4-3. BRT traffic signals should be separated horizontally and vertically from general traffic signals by a distance of at least 3 feet.

**4-4. SIGNAL PRIORITIZATION**

Bus delays at traffic signals account for 10 to 20% of overall bus travel times and 50% or more of all delays. Therefore, adjusting signal timing to expedite BRT, as well as general



(SOURCE: Adapted from *Manual on Uniform Traffic Control Devices for Streets and Highways, Millennium Edition, 2001*)

Figure 4-2a. Traffic signs for BRT.

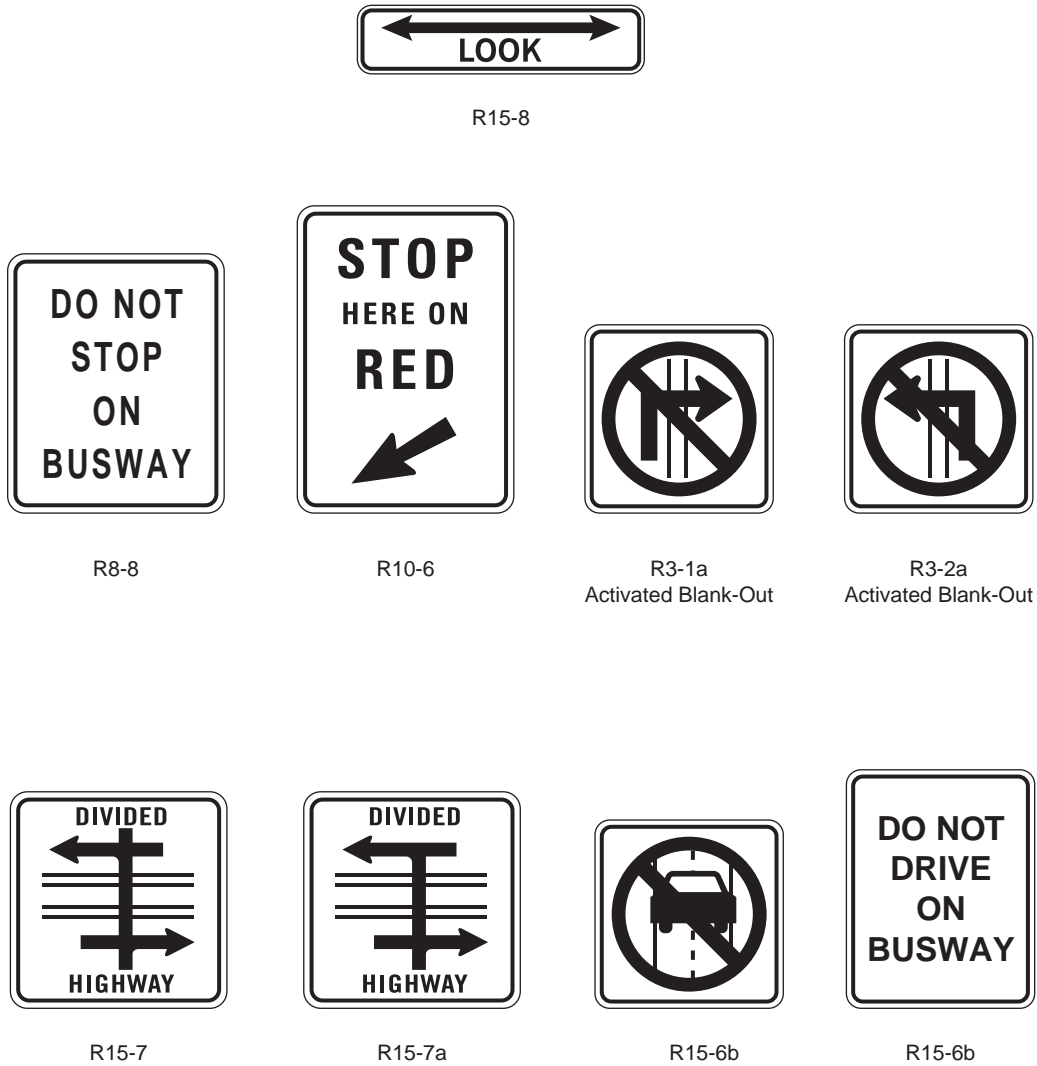
traffic flow, will improve bus speeds and reliability. The underlying philosophy is to minimize overall person delay. However, adjustments to favor BRT, which are often desirable, must be done selectively and carefully.

Traffic signal controls for BRT include passive, active, and real-time priorities as well as preemption (examples of each are provided in Table 4-3) (*Final Report, 2001*; Shen et al., 1998):

- **Passive priority techniques** are designed to improve BRT speeds by modifying existing signal operations. Signals should be timed to minimize delays to buses by adjusting the signal cycle length and split, by minimizing the number of phases, by using short cycle lengths

when practical, and by maximizing the green times along BRT routes.

- **Special phases** can be provided for BRT where they conflict with other movements. They can be pre-timed or actuated.
- **Active priority techniques** adjust the signal timing after a bus is detected. They can advance or extend the artery green time for oncoming buses within the established signal cycle.
- **Real-time techniques** consider both automobile and bus arrivals at a single intersection or a network of intersections. Applications have been limited to date and require specialized equipment.



(SOURCE: Adapted from *Manual on Uniform Traffic Control Devices for Streets and Highways, Millennium Edition, 2001*)

Figure 4-2b. Additional traffic signs for BRT.

- **Preemption** results in changes to the normal signal phasing and sequencing to provide a clear path for oncoming buses. Because of its impacts to both signal coordination and pedestrian safety, it must be very carefully applied.

#### 4-4.1. Passive Signal Priorities

Passive signal priorities improve BRT speeds by modifying signal operation within the established signal systems to be more responsive.

































##### 4-4.1.1. Number of Phases

The number of phases should be as few as possible. Basic two-phase operations should be encouraged, and complex multi-phase operations should be avoided. This calls for careful consideration of intersection geometry, traffic con-

trols, and signal phasing. Exclusive pedestrian phases should be the exception rather than the rule.

Median arterial busways will require additional phases to avoid turning conflicts between buses and automobiles. In these cases, longer cycle lengths will be needed to accommodate conflicting movements and to provide sufficient time for pedestrians crossing the artery. Some considerations for phasing are the following:

- Traffic signal sequences should have the artery left-turn phase follow the through phase along the artery. This is essential to avoid same-direction sideswipes—an accident problem that was reported along several median-aligned LRT lines. The suggested sequence of signal phases is shown in Figure 4-4.
- An additional lane should be provided within the busway for buses making left turns at signalized intersections. The signal phasing should provide a bus-actuated protected movement for the buses turning left.

One-Lens Signal	Three-Lens Signal	Two-Lens Signal
<p><b>SINGLE LRT ROUTE</b></p> 	<p>STOP </p> <p>PREPARE TO STOP  <i>Flashing</i></p> <p>GO </p>	<p> STOP</p> <p><sup>(2)</sup> GO</p>
<p><b>TWO LRT ROUTE DIVERSION</b></p> 	<p></p> <p> <i>Flashing</i></p> <p> <sup>(1)</sup></p>	<p></p> <p> <sup>(1),(2)</sup></p>
<p></p>	<p></p> <p><i>Flashing</i> </p> <p> <sup>(1)</sup></p>	<p></p> <p> <sup>(1),(2)</sup></p>
<p><b>THREE LRT ROUTE DIVERSION</b></p> 	<p></p> <p> <i>Flashing</i></p> <p>  <sup>(1)</sup></p>	<p></p> <p>  <sup>(1),(2)</sup></p>

NOTES:

All aspects are white.

(1) Could be in single housing.

(2) "Go" lens may be used in flashing mode to indicate "prepare to stop."

(SOURCE: Adapted from *Manual on Uniform Traffic Control Devices for Streets and Highways, Millennium Edition, 2001*)

Figure 4-3. Typical LRT signals applicable to BRT.

Special signal phases are required in special circumstances. Some illustrative examples of special bus phases are shown in Figure 4-5. The special phases can be actuated (or preempted) when buses arrive, or they can operate pre-timed. Except for isolated locations, the special phases should be part of overall background cycles.

4-4.1.2. Cycle Lengths

Cycle lengths should accommodate peak traffic flows, let pedestrians cross safely, allow a reasonable allocation of

green time among conflicting flows, and permit coordination at desired speeds. Within this context, *cycle lengths should be as short as possible* along BRT routes. A good practical range is 60 to 90 seconds. Longer cycles (up to 120 seconds) should be limited to major multilane arterial intersections, bridge approaches, expressways, and complex multi-leg intersections. Longer cycles may sometimes be appropriate during peak periods to provide more arterial green time, to permit longer platoons, and to reduce the number of start-up delays.

The shorter cycles have the effect of reducing red times for buses—especially in bus lanes. For a 60-second cycle,

**TABLE 4-3 Bus signal priority systems**

Treatment	Description
<b>Passive Priority</b>	
Adjust Cycle Length	Reduce cycle lengths at isolated intersections to benefit buses
Split Phases	Introduce special phases at the intersection for the bus movement while maintaining the original cycle length
Areawide Timing Plans	Preferential progression for buses through signal offsets
Bypass Metered Signals	Buses use special reserved lanes, special signal phases, or are rerouted to nonmetered signals
Adjust Phase Length	Increased green time for approaches with buses
<b>Active Priority</b>	
Green Extension	Increase phase time for current bus phase
Early Start (Red Truncation)	Reduce other phase times to return to green for buses earlier
Special Phase	Addition of a bus phase
Phase Suppression	Skipped nonpriority phases
<b>Real-Time Priority</b>	
Delay-Optimizing Control	Signal timing changes to reduce overall person delay
Network Control	Signal timing changes considering the overall system performance
<b>Preemption</b>	Current phase terminated and signal returns to bus phase

the likely maximum red time is 30 seconds, for multi-phase operations on a 120-second cycle, the red times would be 60 to 80 seconds. This finding has also been reported in the United Kingdom (Gibson, 1996).

Cycle lengths of 50, 60, 72, 75, 80, 90, 100, and 120 seconds result in an “even” number of cycles per hour. This enables BRT vehicles to be scheduled at the same time on a cycle-to-cycle basis each day.

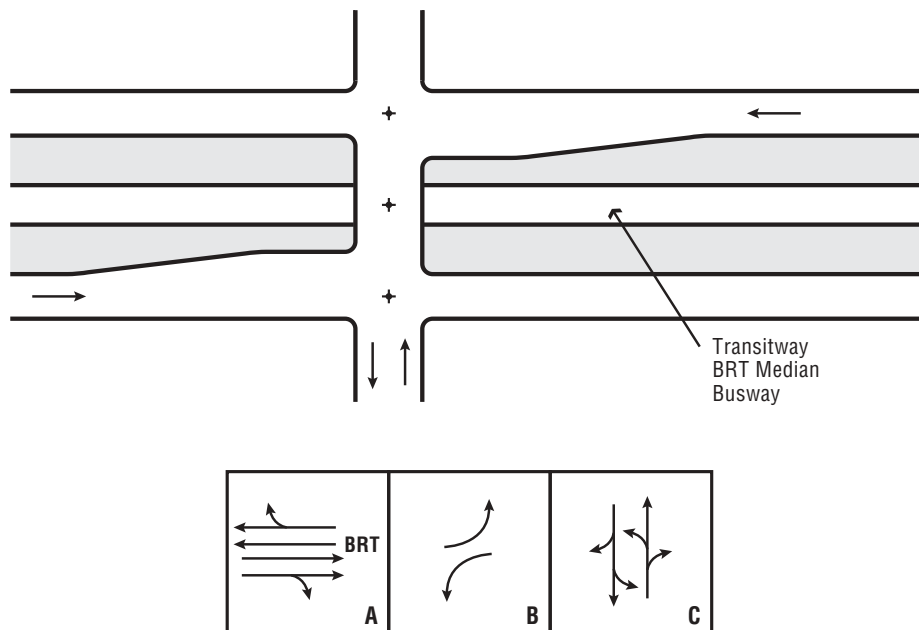
4-4.1.3. Intersection Timing

The green times along BRT routes should be maximized. Intersection timing should consider the relative numbers of people moved per lane on each intersecting street rather than

merely the vehicle movements. This translates into providing as much green time as possible along BRT routes, while still providing sufficient green time for pedestrians crossing the BRT artery. This approach contrasts with the traditional method of signal timing that considers the time needed by pedestrians to cross each street at the intersection, the time needed by traffic on each intersection approach, the individual phase requirements, and the relation to other signalized locations along the street.

4-4.1.4. Coordination

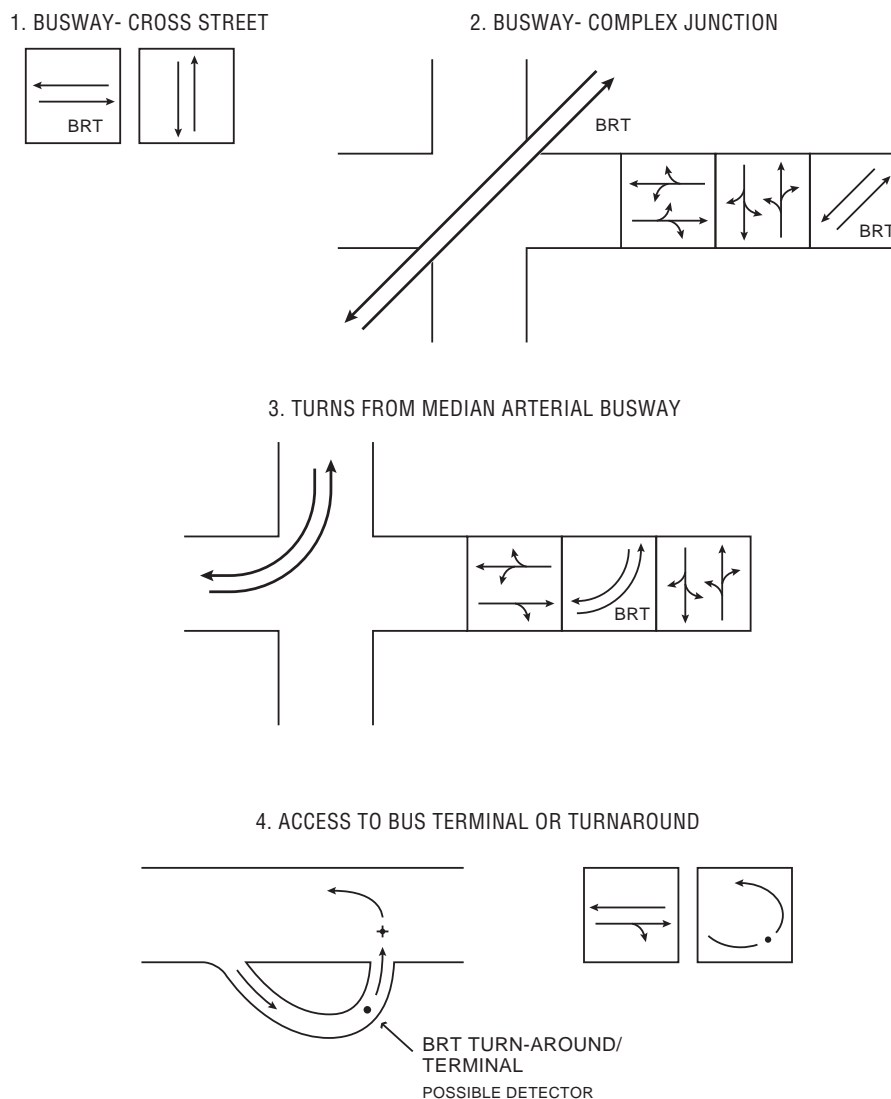
Traffic signals along a BRT route should be coordinated where signals are 1 mile apart or less. Coordination is most



NOTE: BRT phases may be pre-timed or actuated

Figure 4-4. Suggested traffic signal sequence for median arterial busways.





NOTE: BRT phases may be pre-timed or actuated

Figure 4-5. Examples of special bus phases.

effective when signals are spaced at uniform intervals. In some cases (as along streets with heavily used bus lanes), the signals can be set for buses. This practice is followed in downtown Ottawa where bus speeds average 9 miles per hour (as compared with 5 to 6 miles per hour in other city centers).

#### 4-4.2. Active Signal Priorities

Active bus priorities at traffic signals extend or advance the green time for oncoming buses within the established cycles. Thus, they can further reduce BRT travel times and running time variability. These priorities are especially applicable when buses operate in mixed traffic. They will also benefit BRT operations in bus lanes and median arterial busways.

As with other BRT priority treatments, the total person minutes saved by BRT and other vehicles along the artery should outweigh the increased delays to people in vehicles

on intersecting streets. More specifically, increases in green time achieved by advancing or extending the green light are desirable whenever the following conditions apply:

- The person minutes saved by bus and automobile passengers along the BRT artery exceed the person minutes lost by side street automobile drivers and passengers,
- Side street green time can be reduced and still provide adequate clearance time for pedestrians, and
- Increased queues on side streets will be manageable.

##### 4-4.2.1. Description

BRT vehicles can get preference at signalized intersections by advancing or extending the artery green time. Buses are detected as they approach the intersection by various detection technologies. This information is then transmitted to the

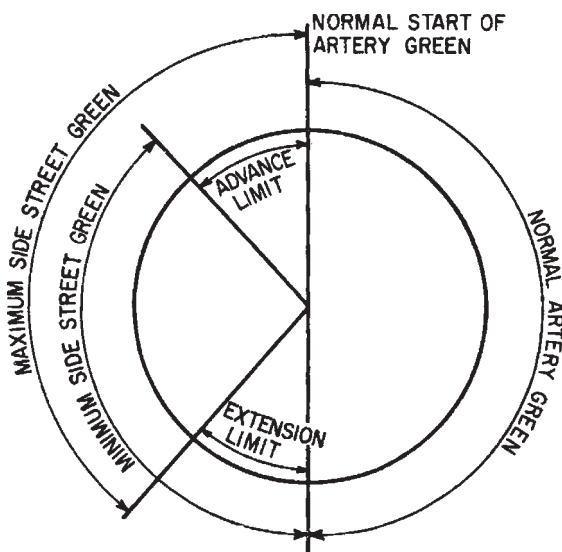
master and local traffic signal controllers. Chapter 7 provides technical details on various vehicle detection technologies and their relation to AVL.

Bus detection should take place *before* buses reach the stop line. When the detection occurs during the artery green time, the artery green is *extended* to enable buses to clear the signal. If the detection occurs during the yellow (clearance) or red intervals, the green time can be recalled in *advance* of its normal time. These timing adjustments reduce the maximum delay time to buses by reducing the red interval.

The basic transit priority concept is shown in Figure 4-6. The modifications of artery green time are done *within* the prevailing traffic signal cycle to maintain artery coordination and to prevent successive signals along a street from operating on different cycle lengths. Guidelines for active signal priorities include the following:

- A minimum side street green is required in each cycle. It must provide adequate time for pedestrians to cross the artery.
- The artery green may be advanced up to a specified period before it takes place or extended up to this amount after it takes place.
- The artery green should not be advanced and extended in the same cycle.

The extent that the artery green time can be increased will depend on the side street volumes, coordination requirements,



NOTE: A. The minimum side street green is required each cycle.  
 B. If the Artery green is advanced, it should not be extended in the same cycle, but  
 C. If the Artery green is extended, it should not be advanced in the next cycle.  
 D. Yellow intervals are not shown  
 (SOURCE: LEVINSON et al., 1975)

Figure 4-6. Bus signal priority concept.

prevailing cycle lengths, and artery roadway width. The effects of these factors on the additional green times are illustrated in Figure 4-7. The green time can be increased the most at locations where cross street volumes are light, but increases may have to be limited at major intersecting streets. Increases in queues on cross streets should be kept to a minimum. When buses arrive every cycle or move frequently, it may be desirable to limit the amount of additional green time to avoid queue buildup on intersecting streets.

#### 4-4.2.2. Bus Priority (Preferences)

Bus priority at traffic signals can reduce transit travel times and running time variability. Generally, about a quarter to a third of transit delays in central areas are attributed to signals. Priority at traffic signals is applicable especially when buses or BRT operate in mixed traffic and when it is not practical to provide bus-only lanes. Priority also can be provided for bus lanes and at-grade busways. However, when buses arrive every cycle (or more frequently), the amount of the additional green time should be limited to avoid queue buildup on intersecting streets.

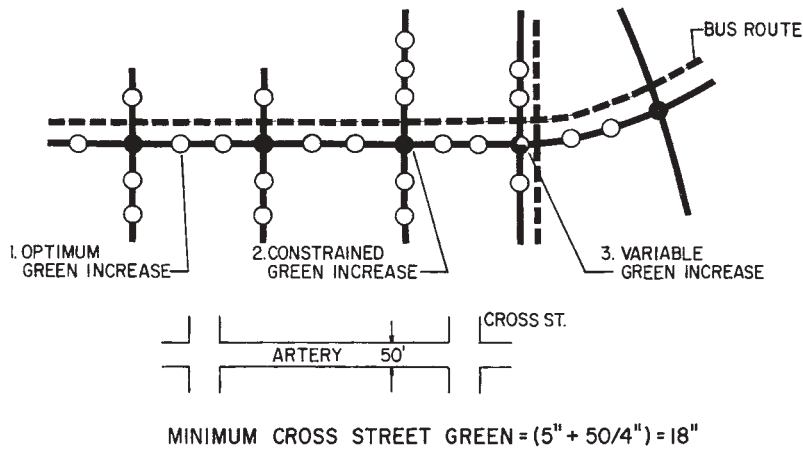
Heavy pedestrian volumes, major (sometimes equal) intersecting bus volumes, and frequent intersection spillback will limit the benefits of bus priority at traffic signals in the city center. Consequently, the best potential for active signal priority is along arterial BRT routes at locations where side street progression is not a significant factor.

There is a relatively narrow range within which the green time can be adjusted in most cases. In Los Angeles, for example, the maximum additional green time is 10% of the signal cycle. Bus delays were reduced with negligible impacts to cross street traffic. The City of Los Angeles reported that bus headways should not be less than 2.5 to 3.0 minutes to enable major cross streets to recover from the time lost (*Final Report*, 2001). These green (and red) time adjustments can be finetuned to minimize total person delays.

#### 4-4.2.3. Control Strategies

Several different control strategies can be used to reduce the maximum delay time to buses by reducing the red interval. They may be conditional (whenever the bus arrives in the designated window) or unconditional (subject to certain constraints). Examples of strategies are provided in Table 4-4. See Chapter 7 for further technical details. Some control strategies are the following:

1. Buses can receive the additional green time whenever they arrive within the specified green time window (unconditional).
2. Buses can receive the additional green time only when they are late. This requires integration of the signal detection with an automatic vehicle location and control system (conditional).



PRE-EMPTION CONDITION	60" CYCLE			80" CYCLE		
	ARTERY GREEN	RANGE ARTERY GREEN	CROSS ST. GREEN	ARTERY GREEN	RANGE ARTERY GREEN	CROSS ST. GREEN
1. ○ OPTIMUM ISOLATED CROSS STREET INTERSECTION	33"	33"–42"	27"	44"	44"–62"	26"
2. ● CONSTRAINED (BY NETWORK CONSIDERATIONS)	30"	30"–36"	30"	40"	40"–46"	40"
3. ⊙ VARIABLE (BUS PRE-EMPTION EACH WAY)	30"	24"–36"	30"	40"	34"–46"	40"

(SOURCE: Levinson et al., 1975)

Figure 4-7. Bus signal priority concepts for arterial streets.

TABLE 4-4 Elements of signal priority control systems

	Element	Examples of Possible Strategies
Highly Desirable	Pedestrian clearance interval	Allow pedestrian interval and clearance intervals to expire before changing phases
	Conflicts with emergency vehicles	Allow emergency vehicles to override bus priority request
	Minimum green interval of current phase	Allow minimum green interval to clear for phase in operation before changing phase to favor bus
	Yellow change interval and all-red clearance interval	Allow yellow change interval and all-red clearance intervals to clear before changing signal to green for bus
Optional	Selective response to buses	Provide priority only to buses running behind schedule
	Frequency of response to bus priority calls	Once a bus has received priority treatment, will not provide priority treatment to other buses until one full cycle has elapsed; may not allow priority response more often than every other cycle.
	Length of time to hold green light for bus	Will not extend green for buses beyond maximum green interval allocated to that phase
	Effect of signal priority on signal coordination	After bus priority call handled, traffic signal returns to its coordination scheme within 30 seconds, even if signal must skip a phase

SOURCE: Rutherford et al., 1995.

3. Advances and extensions can be more frequent than every other cycle only when buses are late. This requires tying the signal detection to the master traffic signal control computer, as is done along Wilshire and Whittier Boulevards in Los Angeles.
4. New multi-phase (e.g., Type 2070) controllers can provide additional green time for buses in each signal phase. This is achieved by providing special “next phase” software in each local intersection controller. A schematic portrayal of this concept as compared with the traditional application is shown in Figure 4-8. This concept has been used on the Salt Lake City LRT line. It is applicable when BRT operates within median arterial busways and other at-grade busways (conditional or unconditional).

**4-4.3. Signal Priorities for Queue Bypasses and Gating**

Active traffic signal priorities can be used in conjunction with queue bypass bus lanes to reduce delays and to facilitate reentry into the traffic stream. On arterial roads where there is not enough space for a bus lane for the entire length of the road, several agencies have installed queue bypasses. Short lanes leading to the intersection are added so that the transit

vehicles can bypass the queue of automobiles and get to the front of the line.

This technique can be enhanced by using signal queue jumps, which allow the transit vehicles a few seconds head start on the rest of the vehicles at the intersection. Buses are allowed to reenter the regular lanes in front of the other vehicles, thereby preventing bottlenecks downstream of the intersection. These lanes are found in several U.S. urban areas, including Seattle and San Diego. In Seattle, a short curb queue bypass lane is located on Pacific Street and Montlake Boulevard, near the University of Washington. A bus-only queue bypass operates on downtown Second Avenue as part of a multi-block bus lane. An advance green signal is also provided for the Airport Road HOV lane in Snohomish County. In San Diego, a bus bypass lane at a signalized intersection in the Mission Valley area is located between the right-turn lane and the general purpose lane (Rutherford et al., 1995).

In conjunction with queue bypass bus lanes, it is desirable to provide a bus-actuated advance green indication of about 5 to 10 seconds for buses. To avoid motorist confusion, the standard “Transit” signals should be used for bus movements.

Bus priority gating is a technique related to signal queue bypasses. This technique stops non-priority traffic short of the intersection while the priority traffic (buses) proceeds to the main stop line. As the signal turns green, the buses proceed ahead of non-priority traffic. Bus priority gating is used in a few cities in Great Britain and in Berne, Switzerland. A bus advance area before the main signalized intersection is used to store buses and give them entry into the main intersection *in advance* of queued traffic. A set of pre-signals holds general purpose traffic, allowing buses to advance around the general traffic queue.

Bus priority gating and advance areas can accomplish several objectives: (1) they can be used when a bus lane is ending to enable buses to reenter the traffic stream, (2) they can be used to allow buses to jump to the front of a queue at a traffic signal after they have picked up passengers at a bus stop, and (3) they can allow buses to jump ahead of other traffic to cross over lanes to reach the left-turn lane without obstruction.

Figure 4-9 shows how gating can facilitate buses making left turns from a curb bus lane on approaches to an intersection. The advance area should be able to store at least two buses per cycle (e.g., about 100 to 150 feet). The block spacing between street intersections should be at least 400 feet. The artery traffic signals for general purpose traffic would be green at the same time at both intersections. On actuation, the bus lanes would get the green indication during the phase in which the cross-street traffic moves.

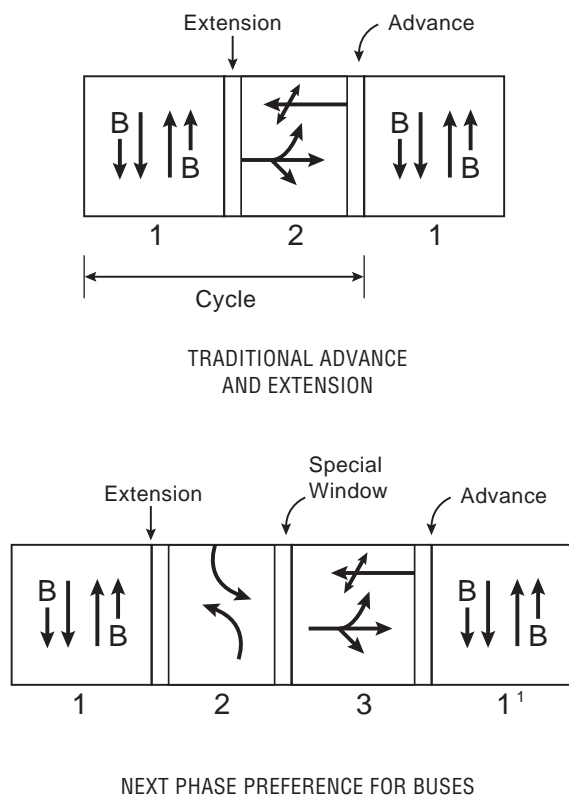


Figure 4-8. Traditional and next phase signal preference concepts.

**4-5. ENFORCEMENT**

The success or failure of a BRT project is critically dependent on keeping running ways clear of improper use by auto-

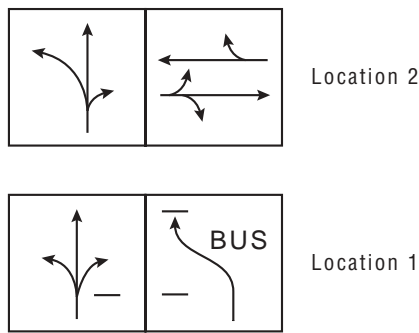
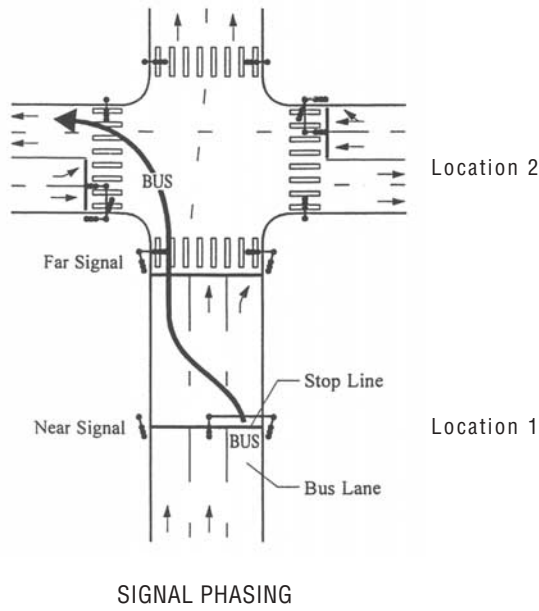


Figure 4-9. Signal priority for left turns from right curb bus lane.

mobiles, taxis, and trucks. Public perceptions of violations can ultimately affect the respect and support for BRT. Therefore, effective enforcement and monitoring of BRT running ways and traffic regulations are essential.

**4-5.1. Enforcement Agencies**

Enforcement policies, programs, and activities involve various groups and agencies. These groups include state DOTs, transit agencies, state and local police, state and local judicial systems, local municipalities, metropolitan planning organizations, rideshare agencies, and federal agencies. Key elements of enforcement activities include the following:

- Legal authority,
- Citations and fines,
- General enforcement strategies,

- Specific enforcement technologies,
- Funding, and
- Communication techniques.

Enforcement should be done by the jurisdictions that have primary responsibility for the BRT facility. Typically, municipal police monitor city streets, and state police monitor freeway-related facilities. However, it may be desirable for special transit agency police to enforce busways and other running ways. The type of enforcement will depend on the specific running way treatment. Examples of enforcement problems and potential approaches for various types of running way are given in Table 4-5.

Some running way designs are deterrents by themselves because of the different types of operations and driving behaviors. Tolerable violation rates on urban streets should be much lower than those on limited-access highways; to accomplish this, urban streets will require more rigid enforcement than busways.

**4-5.2. Enforcement Strategies**

Past studies have classified enforcement strategies by highway and police patrols into one of three categories: routine enforcement, special enforcement, or selective enforcement. Routine enforcement is randomly conducted, whereas special enforcement entails specific planning including team patrols and roving or stationary enforcement patrols. Selective enforcement combines the two strategies and may focus on problem locations. The latter two strategies are only conducted on a short-term basis because of their high cost, and they may not have an immediate impact on violation rates. A passive approach has patrols reroute violators to a more circuitous route; violators thereby encounter a travel-time penalty in their trips. To facilitate enforcement, special enforcement areas should be located along BRT bus lanes where space exists. Video surveillance of violators is desirable.

Enforcement of bus lanes should include both *fines* and towing. Fines for illegal use of bus lanes and curb parking violations should be set at high levels (e.g., \$50 to \$250 per violation). There should be an aggressive towing program for illegally parked vehicles along bus routes and in bus lanes. Immediately towing and impounding violating vehicles has proven effective.

Another means for managing violators of restricted lanes is through penalties and public awareness. In addition to levying fines, some states give penalty points that are put against a driver’s record. Public outreach, such as posting penalty information on signage, also has been used to educate motorists about regulations along the targeted roadways. The California DOT found that the number of citations declined by 61% when fines were posted.

**TABLE 4-5 Enforcement strategies for running ways**

Treatment	Typical Violations	Enforcement Strategies
Median lane, concurrent flow	Unauthorized use of exclusive lane	Public education and heavy enforcement
	Illegal left turn across exclusive lane	Identification and enforcement of upstream violators
		Use of closed left-turn bays for patrol-car observations as apprehension areas
		Transit marketing and good design for bus access to exclusive lane
Bus lane, curbside concurrent flow	Illegal parking and stopping in bus lane	Use civilian agents or provision of police incentives
	Unauthorized use of exclusive lane	Public education and posting of fines
	Illegal left turns and crossing of contra flow lane	Heavy initial enforcement and towing of parked vehicles
	Illegal pedestrian maneuvers	Passive enforcement and travel-time penalty
Special enforcement on opposite curb lane		
		Continuing enforcement
Median lane, contra flow	Unauthorized use of bus lane	Design features of self-enforcement
	Illegal left turns and crossing of contra flow lane by pedestrians	Adequate lane markings and signing
	Inattentive crossing of contra flow lane by pedestrians	Concentrated enforcement at intersections
Curb lane, contra flow	Illegal parking, stopping, or standing	Use of monitors for peak-hour enforcement
	Illegal pedestrian and bicycle movements	Use of monitors for peak-hour enforcement, plus heavy fines and immediate towing to penalize violators.
Bus-only streets	Unauthorized use of bus street	Little enforcement required
	Illegal crossing by pedestrian	
Signal preemption	Transmitter held by unauthorized party	Routine traffic enforcement measures
	Running of red light by motorists due to phase changes	
	Running of red light by bus operator because of pre-anticipation of green phase	

SOURCE: Adapted from Rutherford et al., 1990.

In the greater Houston, Seattle, and Washington, D.C./Northern Virginia areas, the “HERO” program has become an important part of bus and HOV lane enforcement and public education. This program allows witnesses to call and report violators of the restricted lanes. At the same time, “HERO” provides the opportunity to educate violators. An initial evaluation report in Seattle indicated a one-third reduction in violation rates after the “HERO” program was established. The proliferation of cellular phone use has made this program even more effective.

**4-5.3. Enforcement Technologies**

Various technologies can be employed for monitoring and enforcement. Some strategies use TV monitors to direct enforcement. Another, perhaps more controversial, form of enforcement uses Photocop applications, in which violators receive a picture and fine in the mail. (Rutherford et al., 1990).

The use of ITS sensors as an enforcement technology is also being explored. This technology usually relies on automatic vehicle identification (AVI). A pilot system in Dallas, the HOVER system, showed promise by using a combination

of AVI, video cameras, and infrared machine technologies. Portland, Oregon, has conducted an operational test of AVI, in which registered car pools and buses are issued vehicle identification cards that are read at entrance ramps. Northern Virginia and California apply various audio and video techniques to detect violations and then issue citations by mail. The Texas Transportation Institute is investigating ways of using roadside readers. The Georgia Institute of Technology is studying methods that use scanning radiometers to determine the number of people in automobiles. These ITS-related strategies are mainly applicable on busways and freeway bus lanes. Use of colored pavements (e.g., green in New Zealand and Ireland, yellow in Brazil and Japan, and maroon in France) has been shown to ease enforcement problems.

**4-6. CHAPTER 4 REFERENCES**

*Final Report, Los Angeles Metro Rapid Bus Demonstration Program.* Los Angeles County Metropolitan Transit Authority, Los Angeles, CA (July 2001).

Gibson, J. “Effects of a Downstream Signalized Junction on the Capacity of a Multiple Berth Stop.” *Proc. 24th PTRC European Transport Forum.* London, United Kingdom (September 2–6, 1996).

- Levinson, H. S., C. L. Adams, and W. F. Hoey. *NCHRP Report 155: Bus Use of Highways: Planning and Design Guidelines*. Transportation Research Board, National Research Council, Washington DC (1975).
- Manual on Uniform Traffic Control Devices for Streets and Highways, Millennium Edition (MUTCD)*. U.S. Department of Transportation, Federal Highway Administration, Washington, DC (2001).
- Pline, J. L. (ed.). *Traffic Engineering Handbook* (5th ed.). Institute of Transportation Engineers, Washington, DC (1999).
- Rutherford, G. S., R. K. Kinchen, and L. J. Jacobson. "Agency Practice for Monitoring Violations of High-Occupancy-Vehicle Facilities." In *Transportation Research Record 1280*, Transportation Research Board, National Research Council, Washington, DC (1990) pp. 141–147.
- Rutherford, G. S., S. MacLachlan, K. Semple. *Transit Implications of HOV Facility Design*, WA-RP-3961-1. Prepared for Federal Transit Administration by Washington State Transportation Center, Seattle, WA (September 1995).
- Shen, L. D., et al. *At Grade Busway Planning Guide*. Center for Urban Transportation Research, Florida International University, The State University of Florida at Miami, Miami, FL (December 1998).
- Webster, F. V., and P. H. Bly. *Bus Priority Systems*. (Published on behalf of the NATO Committee on the Challenges of Modern Society.) Transport and Road Research Laboratory, Berkshire, United Kingdom (1976).
-

## CHAPTER 5

# BRT STATIONS AND FACILITIES

Bus stops, stations, and terminals, as well as associated facilities such as park-and-ride lots, form the interface between passengers and the BRT system. These facilities should be convenient, comfortable, safe, and accessible to passengers with disabilities. These facilities should support a strong and consistent identity for BRT in the community while respecting and enhancing the surrounding urban context.

Facilities design for BRT is similar to that for LRT, as both modes can operate in a wide variety of running way environments, most often on the surface in urban settings using exclusive or semi-exclusive rights-of-way. Cities that have both LRT and BRT systems (e.g., Rouen and Paris) use the same basic station design for both modes. However, BRT's flexibility and diverse operating environments present unique challenges and opportunities for the facilities designer that are not often encountered in the design of LRT or other fixed-guideway transit modes.

This chapter sets forth the primary considerations in the planning and design of BRT stations and facilities, with an emphasis on issues and elements that are unique to the mode. For detailed discussions of those principles that are common to all modes of transit (such as determining passenger circulation and waiting area requirements), the reader should refer to information contained in sources such as TRB's *HOV Systems Manual* (Texas Transportation Institute et al., 1998); *NCHRP Report 155: Bus Use of Highways: Planning and Design Guidelines* (Levinson et al., 1975); the *Transportation Engineering Handbook* (Pline, 1999); the "Geometric Design Guide for Transit Facilities on Highways and Streets" (NCHRP Project 20-7[Task 135]) (Parsons Brinckerhoff Quade and Douglas, 2002); the *Transit Capacity and Quality of Service Manual* (Kittelson and Associates, Inc., 1999); and *TCRP Report 19: Guidelines for the Location and Design of Bus Stops* (Texas Transportation Institute, 1996). Volume 1 of *TCRP Report 90, Case Studies in Bus Rapid Transit*, provides a wealth of valuable information about existing BRT facilities applications.

### 5-1. SYSTEMWIDE DESIGN AND URBAN DESIGN INTEGRATION

One of the most important roles of BRT facilities design is to support an appealing, cohesive visual identity for the

transit service while at the same time reflecting the varying character of the neighborhoods and districts in its service area. Some important aspects of BRT facilities design are the following:

- *High-Quality Design and Passenger Amenities.* High-quality design—with particular attention to passenger amenities such as shelters, seating, and lighting—supports a positive public perception of the transit service. This is particularly important for BRT, which must overcome negative stereotypes of bus passenger facilities (e.g., small prefabricated bus shelters with poor lighting, minimal signage, and few amenities) that often hamper public support for the mode.
- *BRT as an Urban Design Asset.* Although integration of a BRT guideway into an urban setting presents many challenges, it also presents an opportunity to improve and enrich streetscapes by incorporating new amenities such as landscaping and recreational trails (Figure 5-1). Because guideway construction may displace lighting, sidewalks, and street furniture, these elements can and should be reconstructed or replaced so as to reinforce new, unified design themes. The Orlando Lymmo system is an excellent example of such an approach (see Photo 5-A).
- *Elements of Continuity and Variability.* In addition to projecting an image of quality and safety, BRT running ways and stations should support an integrated system identity, keeping the transit service visible and recognizable to the community as a distinct “brand.” This is accomplished by establishing consistent themes of form, material, and color and applying these themes in the design of one or more system elements such as shelters, signage, guideway pavements, street amenities, and even vehicle livery. Rouen demonstrates how the BRT guideway can maintain a consistent yet respectful presence in varying urban environments (see Photo 5-B).
- *Context-Sensitive Design.* Although a cohesive, branded identity is desirable for the transit service, it is of equal, or greater, importance that BRT facilities recognize the unique character of neighborhoods and districts served by the system. BRT service areas may extend across a wide variety of urban environments and penetrate into the smallest neighborhoods. Systemwide design themes must be sufficiently flexible to



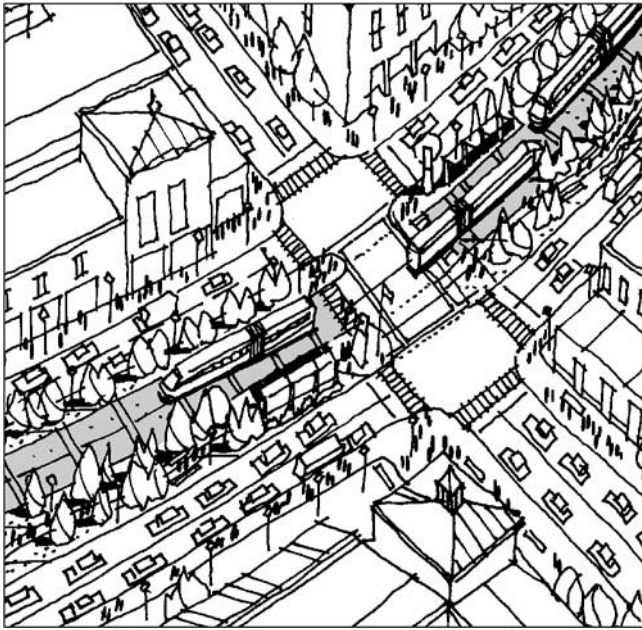


Figure 5-1. BRT guideway in urban setting.

encourage an appropriate balance with the diverse characteristics of neighborhoods. The designer must apply judgment on a project- and site-specific basis to determine the appropriate balance between system continuity and contextual design.

- *Relationship of Transit to Land Use.* As with all modes of public transit, BRT alignments and station locations should be integrated with current and future land use. In general, higher-density, mixed-use development is most favorable to transit because it generates greater patronage, and guideways and stations can often be more effectively integrated into such development. It should be noted that when evaluating potential alignments using abandoned railroad rights-of-way, it is important to bear



(Photo Credit: HHI, Orlando, FL)

Photo 5-A. Orlando Lymmo.



Photo 5-B. Rouen guideway.

in mind that such rights-of-way may not serve high-density areas as well as existing streets.

- *Community Participation.* Station locations and designs should be developed cooperatively with the surrounding community. Community support is essential in identifying and assessing potential sites for transit facilities and for developing design concepts.

### 5-1.1. Station Location and Spacing

BRT station location and spacing are primarily in the realm of operations planning because they strongly influence patronage and operating speeds. However, certain fundamental planning principles will be of interest to the facilities planner.

As a general rule, BRT stations should be placed as far apart as possible, particularly on trunk lines. This is essential to achieving high operating speeds and minimizing trip times. However, station spacing will vary according to the type of running way, development density, and mode of arrival. Suggested guidelines for BRT station spacing are provided in Table 5-1. Generally, the pedestrian arrival mode occurs most often in urban cores, and the automobile arrival mode is most often seen

**TABLE 5-1 Typical BRT station spacing**

Main Arrival Mode	Spacing (Miles)
Pedestrians	0.25–0.33
Bus	0.5–1.0
Automobile	2.0

in the suburbs. However, these are by no means hard-and-fast rules. Because BRT operates in a wide variety of urban environments, a single route may include in-street, pedestrian-oriented collector service in smaller neighborhoods that joins trunk-line service in the secondary and primary urban cores.

Station location should be keyed to major passenger concentrations such as business districts, large office complexes, and employment areas; universities and high schools; cultural and recreational centers; and major residential areas. Stations should be placed where major bus routes and/or major arterial roadways cross or converge at the BRT line, and stations should be configured to provide a safe environment.

## 5-2. STATION DESIGN

This section examines key issues common to design of all BRT stops, stations, and terminals. These include operations planning issues, fare collection, passenger amenities, illumination, safety and security, and barrier-free design. BRT platform characteristics are discussed in Section 5-3.

### 5-2.1. Operations Planning Issues

Operations planning issues are a strong influence on BRT station and guideway design. The flexible, diverse nature of BRT presents issues and challenges that are less common in other fixed-guideway transit modes. Two operations planning issues that require consideration are the following:

- *Platform Requirements.* Close coordination with bus operations planners is essential in planning stations and terminals. Critical program information includes the number of berths needed for revenue service (and lay-over where applicable) and the type of service (e.g., determining whether bus routes will be scheduled and/or assigned to berths, which requires independent bus entry and exit).
- *Bypass Capabilities.* BRT operating plans typically provide both express and all-stop service; it is therefore necessary that express buses be able to bypass buses dwelling in stations. Bypass lanes are essential for bus-only roads (or busways) located on separate rights-of-way and are desirable (where space permits) for median arterial busways. Buses using curb lanes can use adjacent travel lanes as needed. When space is limited, station platforms may be offset to provide far-side stops with offset passing lanes (see Figure 5-4 for an example of offset bypass lanes).

### 5-2.2. Fare Collection

Fare payment and collection policies also have a strong influence on the design of passenger facilities. Unlike conventional transit bus service, BRT often uses off-board fare collection to reduce dwell times and improve the passenger experience by accommodating multiple-door boarding and alighting. (Multiple-door boarding and alighting is essential for high-volume BRT applications.) Off-board fare collection may be accomplished in one of two ways:

- *Controlled Access.* The station environment is divided into *free* and *paid* areas. Passengers pay a fare to pass through turnstiles or other control devices into the paid area of the station. To limit public access, the paid area is enclosed by fare barriers. This arrangement, common in grade-separated BRT systems as well as other modes, is difficult to implement in on-street stations, as the barriers are physically and visually obtrusive. Bogotá is an example of a controlled-access station in an on-street median. Note that a paid area is very difficult to implement for curbside running ways.
- *Proof of Payment.* Under this arrangement, passengers purchase fares in advance of boarding the vehicle (either a multiple-journey pass or single-ride fare), and are required to carry a pass or receipt proving that the fare has been paid. Enforcement is usually performed by police who check a sampling of passengers for proof of payment. This eliminates the need for fare barriers, but places an added burden on personnel and increases operations costs.

### 5-2.3. Passenger Amenities

Public acceptance of BRT can be hampered by negative stereotypes about bus service. Passenger amenities can help to overcome this public-perception issue and should receive a high priority in BRT passenger facilities. Some of the more important amenities include the following:

- *Shelters.* Shelters should be provided at every BRT station and stop. Ideally, shelters extend the full length of the platform so that all vehicle doors are protected. Although high-quality prefabricated shelters are available, consideration should be given to larger, customized shelters that provide added amenities and foster a sense of permanence (see the Los Angeles Metro Rapid system shelters shown in Photo 5-C). Shelters provide overhead shade in warm climates and protect riders from precipitation in all climates. To provide protection against wind and wind-driven precipitation, at least one side of the shelter should have a windscreen (in the coldest climates, shelters should have windscreens on at least three sides, as shown in Photo 5-D). In areas with the coldest winter climates, timed radiant heaters should be considered, although they have disadvantages with regard to maintenance, operating



Photo 5-C. Los Angeles shelter.

costs, and vandalism concerns. Shelter roofs should be configured to direct rainwater and snow away from the vehicle side. Shelters should incorporate materials that are readily available, durable, easy to maintain, and vandal resistant. See Section 5-2.6 for dimensional information.

- **Passenger Information.** All BRT stops and stations should provide some form of consistent passenger information, including the following:
  - **Signage and Graphics.** Bold, prominently placed station identification signage, transit route maps, and



Photo 5-D. Vancouver shelter.

local neighborhood maps should be placed in consistent locations at each station and use common systemwide design themes. Signage and graphics should readily distinguish BRT stations from regular bus stops. If advertising is to be present at stops and stations, the systemwide facility design should establish specific locations and formats that do not conflict with directional and informational signage. Tactile signage and audible information may also be used to serve persons with visual impairments.

- **ITS Displays.** Real-time, variable message signs should be provided at station entries and on platforms to provide “next bus” and systemwide schedule and delay information at each platform. This amenity should receive serious consideration in all systems, as it is greatly appreciated by passengers.
- **Street Furniture.** Whenever possible, stops and stations should accommodate waiting passengers by providing seating and/or leaning rails and trash receptacles.
- **Other Amenities and Facilities.** Other useful passenger conveniences that may be warranted at stops and stations include bicycle racks, newspaper vending equipment, and public telephones. These elements should be placed at consistent locations with respect to the station entrance and platforms. Larger and/or enclosed station or terminal facilities may also provide drinking fountains, restrooms, and expanded retail services such as food and beverage concessions, newsstands, convenience stores, and bank ATMs.

#### 5-2.4. Illumination

Adequate lighting of station buildings, platforms, walkways, roadways, and parking areas is essential to the attractiveness, safety, and security of the BRT station environment. All lighting should be configured to simplify relamping and be vandal resistant. Lighting on open platforms should be in the range of 5 footcandles, with areas beneath canopies increased to 10 to 15 footcandles. Lighting type and illumination levels should be planned in coordination with adjacent, exterior public spaces. Lighting guidelines for parking facilities, streets, and sidewalks can be found in the Illuminating Engineering Society of North America’s *Value of Public Roadway Lighting* (1987) and AASHTO’s *Guide for the Design of Park-and-Ride Facilities* (1992).

#### 5-2.5. Safety and Security

Both actual security and the passenger’s *perception of security* are essential to safe operation and public acceptance of the transit system. Security provisions are essential because BRT stops and stations are likely to be open for extended hours, and many stations are likely to be unattended.

Visibility is the single most important attribute of security. Passengers should be able to *see* their surroundings and *be seen* from locations within and outside the station. Platforms should be sited so that there is an unobstructed view to and from the street or a public way. Abrupt or “blind” corners and dead ends should be avoided in pedestrian walkways. Shelter walls should be glazed so that persons and activity within can readily be observed. Staffed stations should be designed to maximize the station agent’s view of the platform and adjoining passages. Landscaping should be planned so as to not obscure visibility. Ample lighting is also essential to effective and perceptible security; see Section 5-2.4 for additional information.

Security equipment that may be warranted at stations includes closed-circuit television monitoring and prominently placed emergency call boxes. It is important to stress that these items should be used to supplement, not replace, the fundamental principles of station visibility and adequate lighting, discussed in the previous paragraph.

### 5-2.6. Barrier-Free Design

BRT stations should be accessible to persons with impaired mobility. In the United States, station design must comply with the *Americans with Disabilities Act Accessibility Guidelines* (ADAAG) (2000). The facilities designer must be familiar with the applicable guidelines, which consider factors such as pathway width, space for wheelchairs, grades, treatment of obstructions, and placement and design of signs. Chapter 10 of the ADAAG specifically addresses transportation facilities; a brief summary of the guidelines specific to bus transportation facilities follows (state and local building codes must also be consulted in addition to the ADAAG, as standards in some jurisdictions are more stringent):

- Bus shelters must be accessible from a public way via an ADAAG-compliant accessible route that leads to a clear area entirely within the shelter, with a minimum clear floor area at least 30 inches long and 48 inches wide.
- If a vehicle-mounted lift or ramp is to be employed for wheelchair access, a clear area that is 96 inches long (measured perpendicular to the vehicle) by 60 inches wide (measured parallel to the vehicle) is required for lift deployment and wheelchair maneuvering. The cross slope of this area is limited to 2%, measured perpendicular to the vehicle.
- New signage must meet ADAAG standards for character height, proportion, finish, and contrast (bus schedules posted at stops are exempted from this requirement).

## 5-3. BRT PLATFORM CHARACTERISTICS

BRT presents a unique array of options and requirements for platform design. This section presents planning consider-

ations for platforms in all BRT station types, including dimensional guidelines, berth configurations, and platform height and vehicle-interface issues.

### 5-3.1. Berth Quantities and Platform Dimensions

The platform length will generally be governed by the number of bus berths required. This should be based on the design bus volumes and service times at any given station. These berth capacities can be based on the guidelines contained in Appendix A, and a margin of safety is highly desirable. As a general rule, two to three loading positions per platform should be provided along busways. Terminals and major intermodal facilities will usually have more bays, as multiple routes will terminate and originate at these stations.

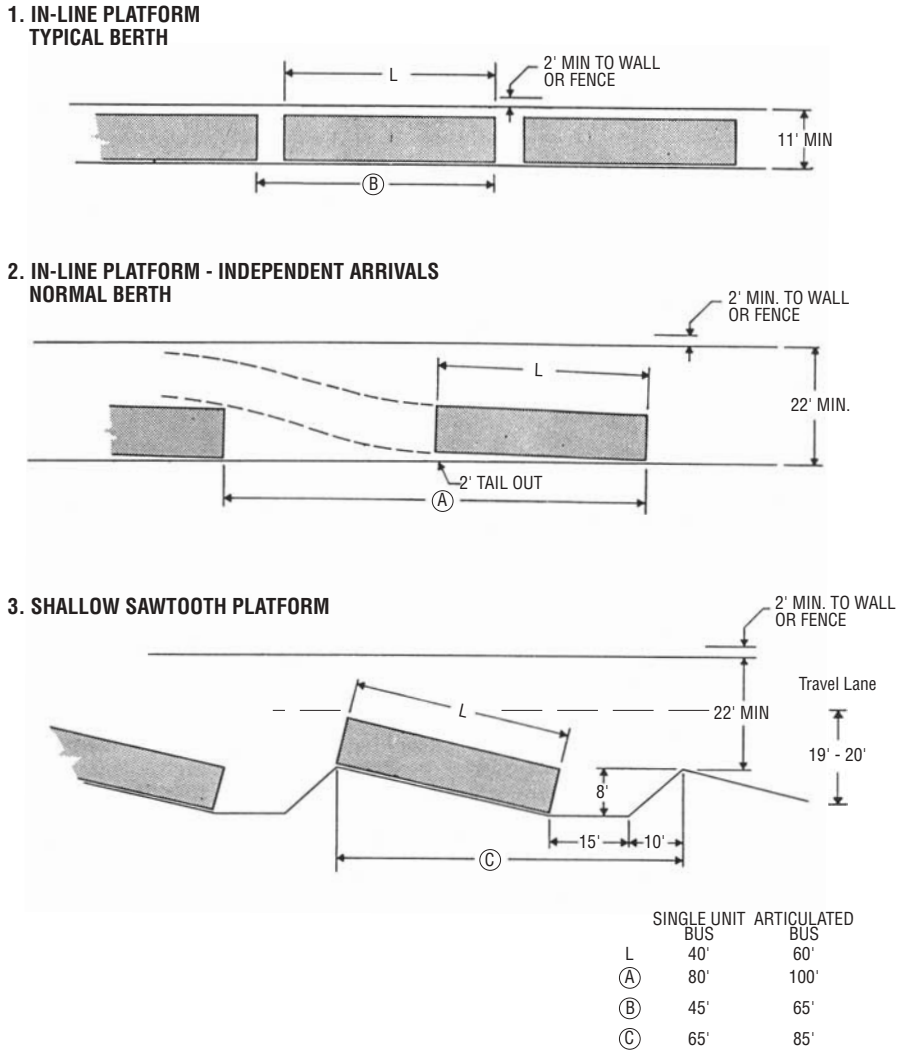
### 5-3.2. Platform Width

Platform width is determined by ADAAG, patronage, and vertical circulation requirements. A minimum clear width of about 10 to 12 feet is desired at curbside bus stops and busway side platforms. For center platforms, a 20- to 25-foot width is desirable. Platform width should accommodate peak 15-minute ridership, using a planning horizon at least 5 to 10 years in the future. Passengers should be able to “clear” the station before the next bus (or group of buses) arrives. Similarly, there should be adequate space to avoid spillback on platforms, especially when fare collection facilities are provided. The facilities planner should consult *Pedestrian Planning and Design* (Fruin, 1987) for complete pedestrian planning guidance. Appendix B contains details on pedestrian capacities and service levels.

### 5-3.3. Berth Types

Bus berth configurations are strongly influenced by the running way configuration and service plan. The latter factor is particularly important because the facility may need to accommodate scheduled operations, in which buses arrive and depart at set times, and therefore must be able to independently enter and exit their berths. This flexibility is not required for headway-based operations. In all cases, driving lanes should be wide enough for buses to pass a disabled vehicle.

Linear parallel berths are well suited to most BRT online stations. They require an additional 11 to 12 feet of space beyond the travel lane. There are two linear berth arrangements. The typical arrangement (see the In-line Platform Typical Berth in Figure 5-2) is for buses to approach and depart in a single line. The first bus to arrive is the first bus to depart. For planning purposes, 5 to 10 feet between dwelling vehicles should be assumed. Thus, a typical two-berth design for 60-foot-long articulated buses along linear platforms would be about 130 to 140 feet. This is the



(Adapted from Levinson et al., 1975 and Fuhs, 1990)

Figure 5-2. Illustrative berth configurations.

most space-efficient configuration. An alternate configuration (see the In-line Platform–Independent Arrivals Normal Berth in Figure 5-2) requires that buses approach the parallel berth from an adjacent travel lane. This allows independent entry and exit, but it requires greater operator skill and more platform length.

Shallow sawtooth bays (see the Shallow Sawtooth Platform in Figure 5-2) allow independent entry and exit and are desirable at terminals. They require a minimum 19- to 20-foot envelope beyond the travel lane for 40-foot buses and an envelope of approximately 23 to 25 feet for 60-foot articulated buses.

Head-in angle docking bays are generally limited to intercity operations and should be avoided in BRT as well as other transit bus operations because they require the bus to back up to leave the stall. These docking bays should be considered only when dictated by space limitations at major terminals, where buses operate at long headways.

### 5-3.4. Side Platform Configurations

Several options exist for the placement and height of platforms. Table 5-2 provides platform features for selected BRT systems. Side platforms may be placed in *tandem* (opposite each other) or staggered. Two platform configurations are the following:

- Tandem side platforms may be used on dedicated busways with grade-separated pedestrian crossings.
- Staggered far-side platforms are desirable along at-grade busways, median arterial busways, and in most curbside operations, especially at signalized intersections. They prevent right-turn conflicts, are more conducive to preferential signal treatments, and may allow left-turn lanes and platforms to use the same envelope. At stations with at-grade pedestrian crossings, they allow pedestrians to cross to the rear of stopped buses.

**TABLE 5-2 Station platform features for selected systems**

CITY/SYSTEM	LOCATION	LENGTH FEET (BUSES)	PLATFORM HEIGHT	PASSING LANES	OFF-VEHICLE FARE COLLECTION
<b>BUS TUNNELS</b>					
BOSTON (SILVER LINE)	SIDE	220(3)	LOW	LIMITED	YES
SEATTLE	SIDE	(2)	LOW	YES	NO
<b>BUSWAYS</b>					
BRISBANE	SIDE	(2–3)	LOW	YES	NO
MIAMI	SIDE	(2–3)	LOW	YES	NO
OTTAWA	SIDE	180(3)	LOW	YES	NO
PITTSBURGH	SIDE	120–240	LOW	YES	NO
<b>MEDIAN ARTERIAL BUSWAYS</b>					
BELA HORIZONTE	SIDE	1–4	LOW	YES	NO
BOGOTÁ	CENTER	130–490	HIGH	YES	YES
CURITIBA	SIDE	80(4)	HIGH	YES	YES
QUITO	SIDE CENTER	(1)	HIGH	NO	YES
SÃO PAULO	SIDE	2–3	LOW	YES	NO

SOURCE: Levinson et al., 2003.

### 5-3.5. Center Versus Side Platforms

Side platforms are most commonly used along busways because they are compatible with conventional bus door configurations (bus doors are typically on the curb side of the vehicle, or the right side in North America). Center platforms (commonly used in rail stations) are rare in BRT because they require either contra flow operations with conventional buses or vehicles with one of the following nonstandard door configurations:

- Dual side doors that add expense and reduce seating capacity or
- Left-side doors that limit use of the vehicle on city streets or in conventional stations (left-side or dual door vehicles are found in a few existing bus systems such as the trackless trolleys in Cambridge, Massachusetts).

If these disadvantages can be overcome, center platforms offer more efficient use of passenger facilities and equipment (particularly vertical circulation) and may yield a narrower overall station envelope.

### 5-3.6. Platform Height and Vehicle Interface

Together with off-board fare collection, the platform/vehicle interface has a strong influence on passenger experience and boarding speed. *Level boarding* minimizes the horizontal and vertical gap between the platform edge and vehicle door threshold. This speeds boarding for all patrons and also allows wheelchair users to enter the vehicle without a lift or other assistance. For wheelchair access on fixed-guideway systems, ADAAG allows a maximum vehicle floor-to-platform gap of

3 inches horizontally and  $\frac{5}{8}$  inch vertically. Although the ADAAG requirement for buses is not as stringent, this is the standard to meet for the highest-quality, barrier-free access. For a bus and platform to meet this standard, some form of *precision docking* system (or a vehicle- or platform-mounted retractable ramp or bridge plate) is required, the platform height must match the vehicle floor height, and the platform must be located along a tangent section of roadway.

**Vehicle-based precision docking systems** include optically guided steering (as used in Rouen) or mechanically guided systems (as used in Adelaide and Essen). These systems are needed to accurately steer the vehicle into alignment with the platform; a human driver cannot repeatedly dock the bus with the accuracy required. The platform itself may be detailed to provide a precision docking interface; one technology under development is the *Kassel Curb*, a concrete curb with a concave profile on its street face. The driver steers the bus so that the bus tires are forced against the curb, which in turn places the bus in the proper alignment with the platform edge. This system has been shown to meet the ADAAG gap standard in regular use, but it is highly reliant on the skill and diligence of the driver. It may also accelerate tire wear because of repeated contact with the curb, and the curb height must be coordinated to avoid conflicts with wheel nuts and vehicle door operations.

**High-platform stations** are most commonly found in heavy rail rapid transit and occasionally in light rail systems. Although high-platform stations are found along BRT lines in Bogotá, Curitiba, and Quito, the trend toward low-floor vehicles has reduced their desirability. In comparison with low platforms, high platforms are more expensive, occupy more space (lengthy pedestrian ramps are required for wheelchair access), are visually obtrusive, and are likely to require a specialized vehicle with greater headroom than a conven-

tional transit bus. They also limit BRT service to places with high platforms, thereby greatly limiting the flexibility of bus operations. ADAAG requires that high platforms be equipped with detectable warning edge treatments such as a 24-inch strip of color-contrasting material with raised, truncated domes.

**Low-platform stations** are becoming increasingly common as more low-floor buses enter service. Low-floor vehicles generally have a floor approximately 12 to 15 inches above the driving surface. This platform height is much more readily integrated into a typical in-street environment. Although ADAAG does not explicitly require a detectable warning on a low bus platform, this kind of platform is still significantly higher than a normal sidewalk, so it is good practice to use the warnings.

**Vehicle-based lifts** are used by some systems to provide access for persons with disabilities using sidewalks and platforms at conventional curb height. Although common, this is not the most desirable approach for new construction because the lift adds significantly to dwell times and has an adverse impact on system reliability. The lift also requires intensive maintenance in order to provide reliable service.

**Bridge plates** that are vehicle or platform mounted and retractable are used by some systems to provide a barrier-free boarding interface without use of a precision docking system. The vehicle is manually steered as close to the platform as possible, and the plate is then deployed to bridge the remaining gap. Like lifts, retractable ramps and bridge plates adversely impact dwell times and require regular maintenance in order to provide reliable service.

## 5-4. STATION CONFIGURATION

This section presents various BRT station types. The station configuration will reflect the type of running way; bus service frequency and operating plan; vehicle type, length, and door configuration; transit operating plan; and fare collection policy. Station configurations should be simple and consistent across the system. BRT station facilities fall into three broad categories:

- Busway, or on-line stations;
- Intermodal and terminal stations; and
- Conventional, in-street stops served by buses in mixed traffic.

### 5-4.1. Busway Stations

Busway or on-line stations are found in two basic configurations:

- Grade-separated busways, including freeway medians; and
- Street-level busways, which may operate in a median reservation, in a curbside restricted lane, or in an interior lane (see Chapter 3).

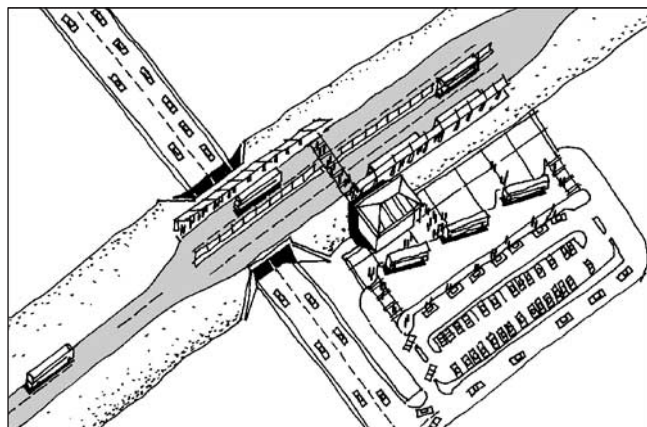
#### 5-4.1.1. Grade-Separated Busway Stations

Grade-separated busways (as in Brisbane, Ottawa, and Pittsburgh) provide passing lanes in each direction at stations. A station design concept is shown in Figure 5-3. Principal features of stations on grade-separated busways include the following:

- A four-lane station envelope, with two bus lanes passing through the station in each direction—one lane for dwelling vehicles at the platform and a bypass lane for express buses.
- Minimum 1:30 roadway tapers on each end of the station.
- A fenced 4- to 5-foot median center island to prevent or control at-grade crossings.
- 12- to 15-foot side platforms.
- Where warranted, a climate-controlled station building housing vertical circulation, fare collection, and retail services. The station building can be located over the busway or along one side of it, as shown in Figure 5-3.

When busways operate in a grade-separated environment, cross-station pedestrian access must be carefully controlled. This is best accomplished with grade-separated walkways (as in Brisbane, shown in Photo 5-E), connected to the platforms by stairways and/or escalators, and elevators.

When it is impractical to provide grade-separated pedestrian access between platforms, staggered, far-side platforms should be used, and the central median barrier may be opened to allow a clearly delineated, at-grade pedestrian crossing at the rear of each platform. To ensure pedestrian safety, at-grade pedestrian crossings must be evaluated on a site-specific basis, considering anticipated bus operating speeds and volumes, transit patron age profile, and sight distances. With bypass lanes, minimum station envelopes of about 75 feet are possible when stairs and elevators are placed at the far ends of platforms. It is more desirable to place these facilities at the center of platforms, but this requires a wider envelope.



(Illustration Credit: Keith Hudson, AIA)

Figure 5-3. Busway station concept.



Photo 5-E. Grade-separated pedestrian crossing from Brisbane.

Alternative configurations of busway station designs (for the planned New Britain–Hartford Busway) are shown in Figure 5-4. Diagram A in Figure 5-4 shows an offset (or staggered) concept that allows the entire busway and station to be provided within a basic four-lane, 48-foot envelope, using staggered, far-side platforms. This concept minimizes real estate acquisition needs and is widely used along median arterial busways in Brazilian cities. Diagram B in Figure 5-4 shows a semi-staggered platform that provides bypass lanes in each direction and results in a 76-foot-wide envelope. Pedestrians cross the busway at a single central location to the rear of each bus stop. Two pedestrian islands in the center of the roadway provide refuge for pedestrians; fencing could be added to preclude errant crossings. Bringing the plat-

forms closer together is an advantage in terms of passenger security.

5-4.1.2. Freeway BRT Stations

BRT may operate along freeways in mixed traffic or in exclusive median or shoulder lanes. On-line freeway stations are located on auxiliary roadways that are physically separated from the main travel lanes to protect stopped buses from errant vehicles and to prevent pedestrians from entering the main freeway lanes. These roadways should be 24 feet wide to enable buses to pass around disabled vehicles. There should be sufficient deceleration distances to minimize delay to other vehicles, and acceleration lanes should be long enough to permit easy reentry into travel lanes. A minimum 1:30 taper for deceleration and a 1:40 taper for acceleration are desirable. If the busway is fully separated from general freeway travel lanes, bypass lanes for express service are likely to be needed, increasing station envelopes by about 25 feet.

As shown in Figure 5-5, either side or center platforms can be used depending on traffic flow and vehicle door configurations. Because most freeway stations will warrant grade-separated pedestrian access with stairs (and/or escalators) and elevators, a center-platform configuration is desirable in order to minimize the cost of these vertical circulation elements.

In some cases, it may be desirable to provide off-line stations adjacent to the freeway. These stations are usually less costly than on-line stations because they simplify station design and pedestrian access. However, this configuration is likely to reduce BRT operating speeds in comparison with a station at the freeway level. Off-line stations are an attractive option for incremental BRT implementation because they can be constructed as a first stage that is followed by construction of

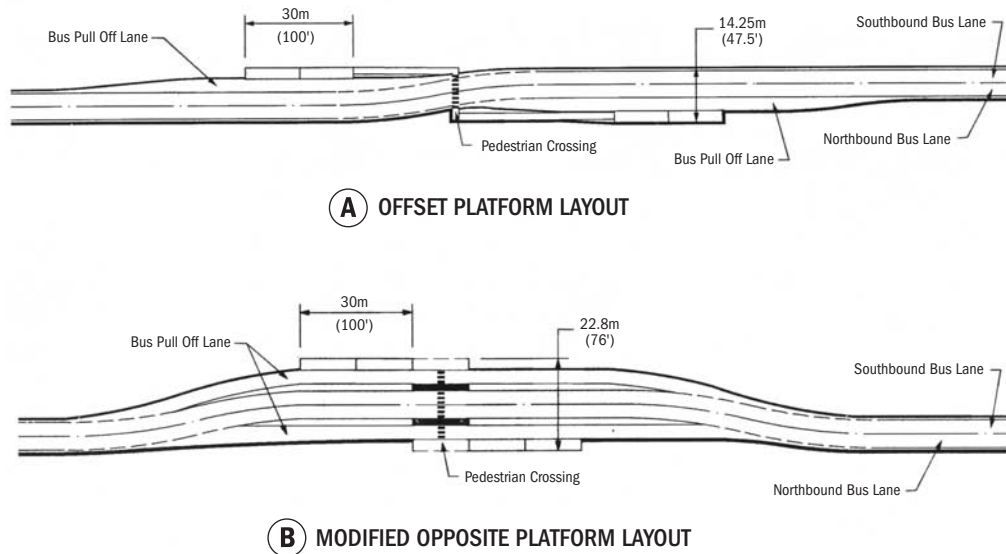


Figure 5-4. New Britain–Hartford platform layouts.



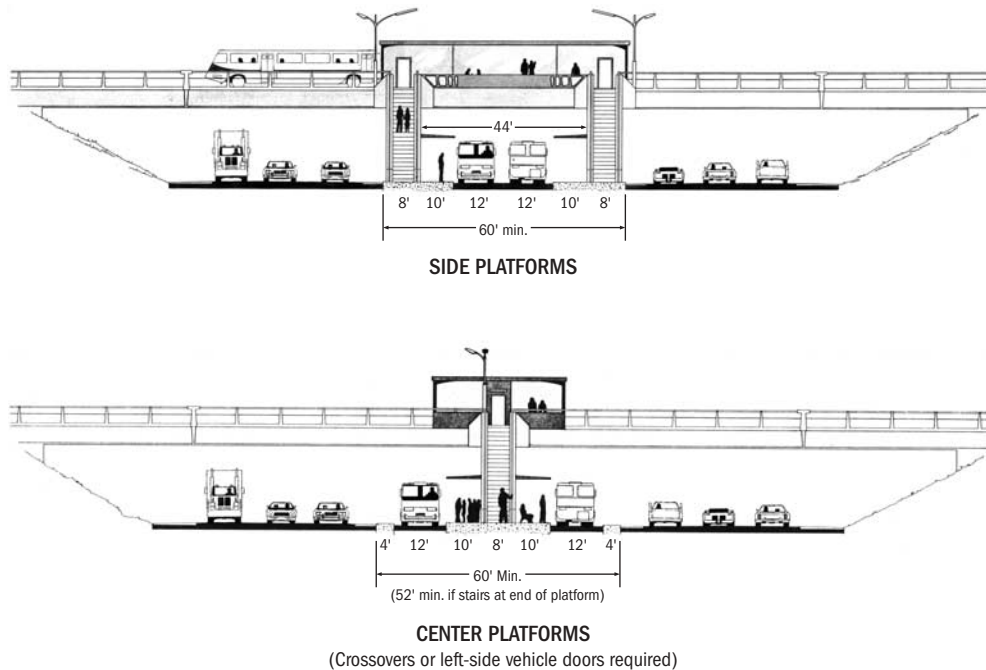


Figure 5-5. Highway BRT stations.

more elaborate in-line stations if warranted by ridership and available funding. Ideally, access to such stations should be via dedicated bus-only ramps, but in some cases patronage, bus volumes, and traffic conditions may allow BRT vehicles to share ramps with general traffic and to operate for short distances on local streets to reach the stations.

#### 5-4.1.3. Median Arterial Busway Station

Median arterial busways provide clear physical BRT identity and offer good schedule reliability at moderate capital costs. Left turns must be carefully controlled (usually by traffic signal phasing), rerouted, or prohibited. Guideways and platforms along median arterial busways are constrained by the street space available and by traffic operations. Pedestrian access to median stations requires patrons to cross traffic lanes; such access should be provided at signalized intersections wherever possible. Three types of platforms are used in median arterial busway stations:

- *Side platforms* should be located on the far side of intersections, as shown in Figure 5-6. This allows near-side left-turn lanes to be placed in the “shadow” of each platform, and it works well with traffic signal prioritization. Left turns should be permitted only at signalized intersections. Pedestrian access should be from the cross street end of each platform. A disadvantage of the far-side configuration is that without signal priority, buses will often be forced to double stop at intersections, once for the signal and once at the platform.

- *Center-island platforms* can be located on one or both sides of a cross-street intersection. (Figure 5-7 shows a single, center-platform configuration). The platform should be at least 20 feet wide. The main pedestrian entrance should be from the cross street, along with any fare equipment. This design concept requires buses that have dual or left-side doors or buses that operate in a contra flow configuration. It also makes left turns very difficult to implement.
- *Midblock stations* with passing lanes can be provided when space is available. As shown in Figure 5-8, a three-lane busway section allows two lanes each way adjacent to the platforms, with a single central pedestrian crossing to the rear side of bus stops.

#### 5-4.1.4. Curbside BRT Stations

Curbside BRT stations, at which BRT vehicles receive and discharge passengers along curbs, can be implemented with low capital costs and minimal loss of general traffic lanes. Curbside stations provide good access for pedestrians and can be readily integrated with the overall streetscape design. Although the stations present no interference with general traffic left turns, they may create right-turn conflicts. Restricted curbside lanes are difficult to enforce and relatively unfavorable in terms of schedule reliability. Curbside stations may be unpopular with abutters because the vehicles and shelters tend to obstruct access to and views of storefront businesses, and the restricted BRT lanes impact access to adjacent driveways, parking, and loading zones. *TCRP Report 19:*

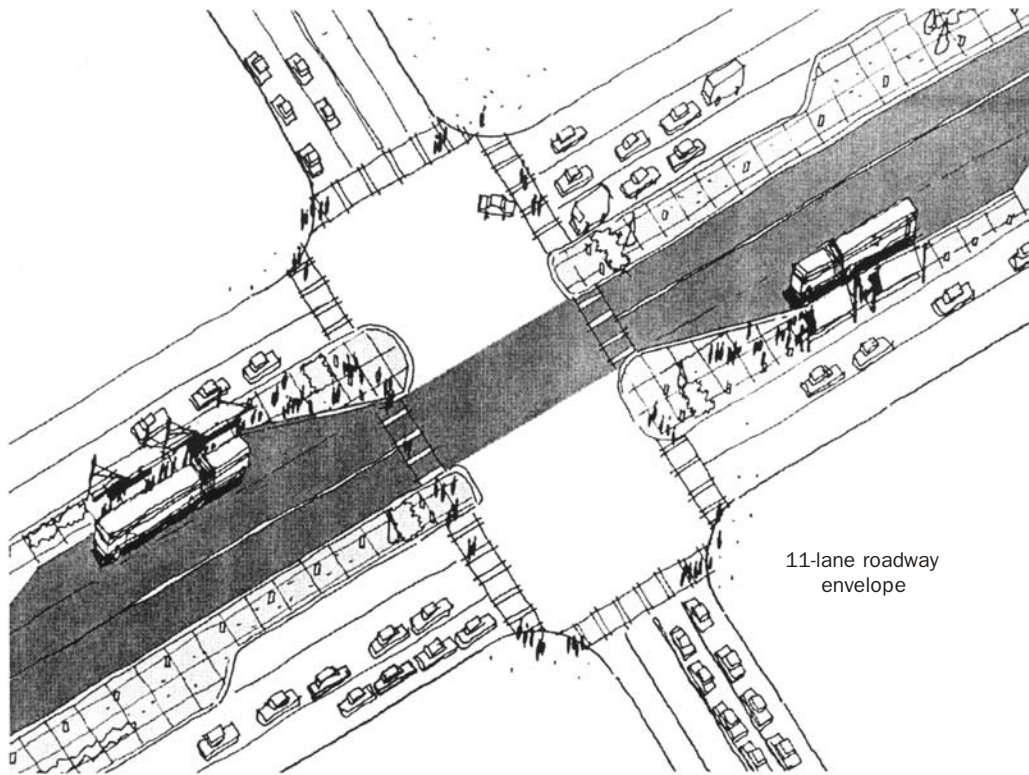
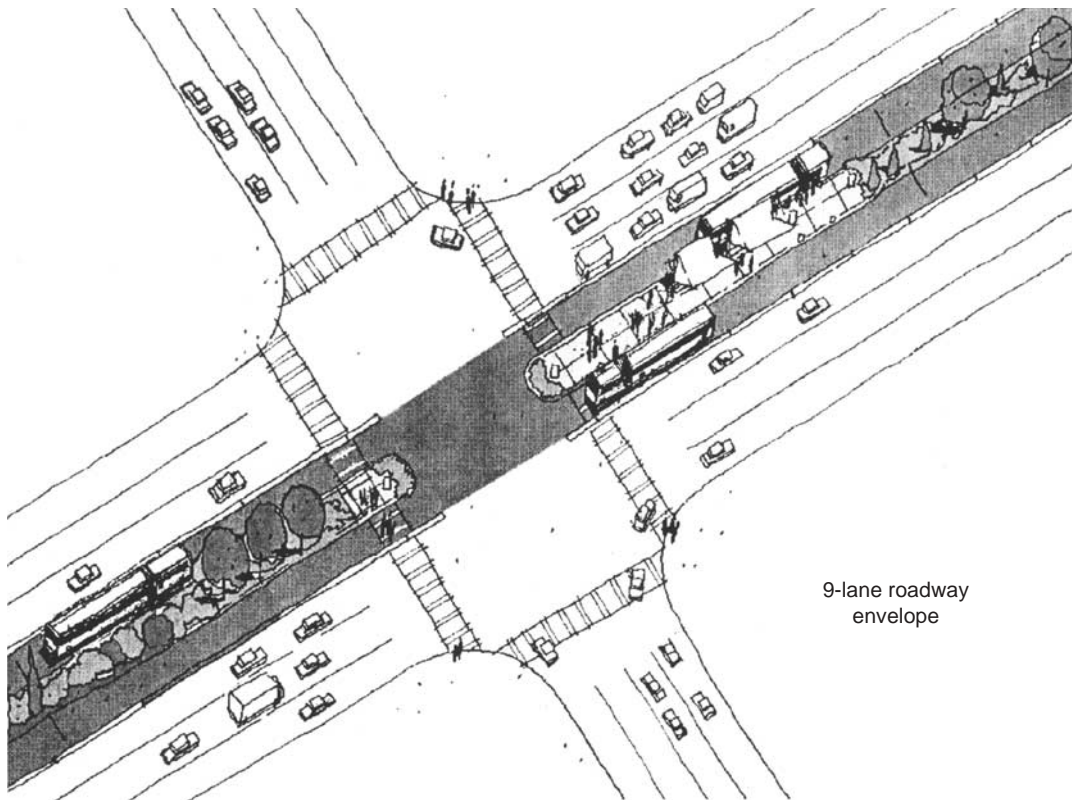


Figure 5-6. Median station, side platforms.



NOTE:  
Prohibit left turns along transitway  
or provide left turn lanes.

Figure 5-7. Median station, center platform.

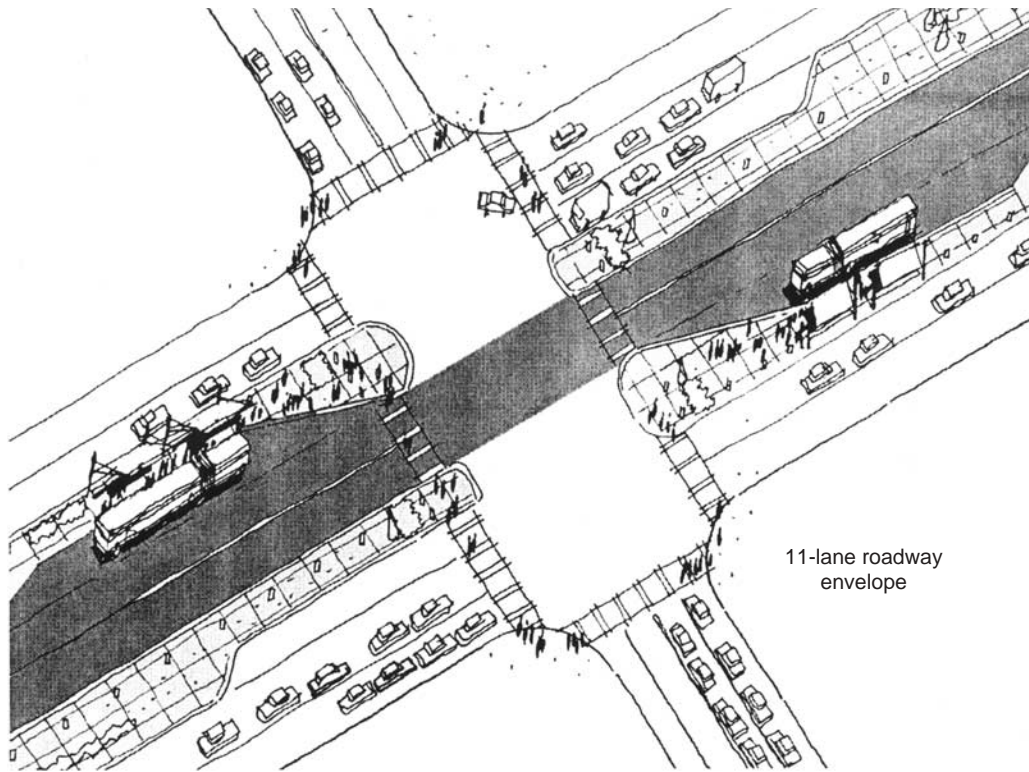


Figure 5-8. Median station, side platform with bypass lane.

*Guidelines for the Location and Design of Bus Stops* (Texas Transportation Institute, 1996) provides very thorough guidance on the design of curbside bus stops.

Curbside stops may be located near-side, far-side, and mid-block, as shown in Figure 5-9. Table 5-3 presents the relative merits of near-side, far-side, and midblock stops, which are summarized as follows:

- Near-side stops are preferable when bus flows are heavy, traffic conditions are not critical, and some curb parking is permitted during peak periods. From the transit operator's point of view, near-side stops make it easier to rejoin the traffic stream, particularly when curb parking is permitted during peak periods. A major disadvantage of near-side stops is that right-turn traffic and departing buses often conflict with each other.
- Far-side stops (shown in Figure 5-10) are preferable when buses have exclusive use of the curb lane, when peak-hour (or all-day) parking is prohibited, and when buses get priority at traffic signals. These conditions are likely to occur under BRT operations.
- Midblock stops are not common in practice, and they are generally limited to downtown areas where multiple routes require long loading areas, possibly extending an entire block. Midblock stops can also occur on extremely long blocks requiring intermediate access points. When a cross street carries a bus route, a near-side or far-side

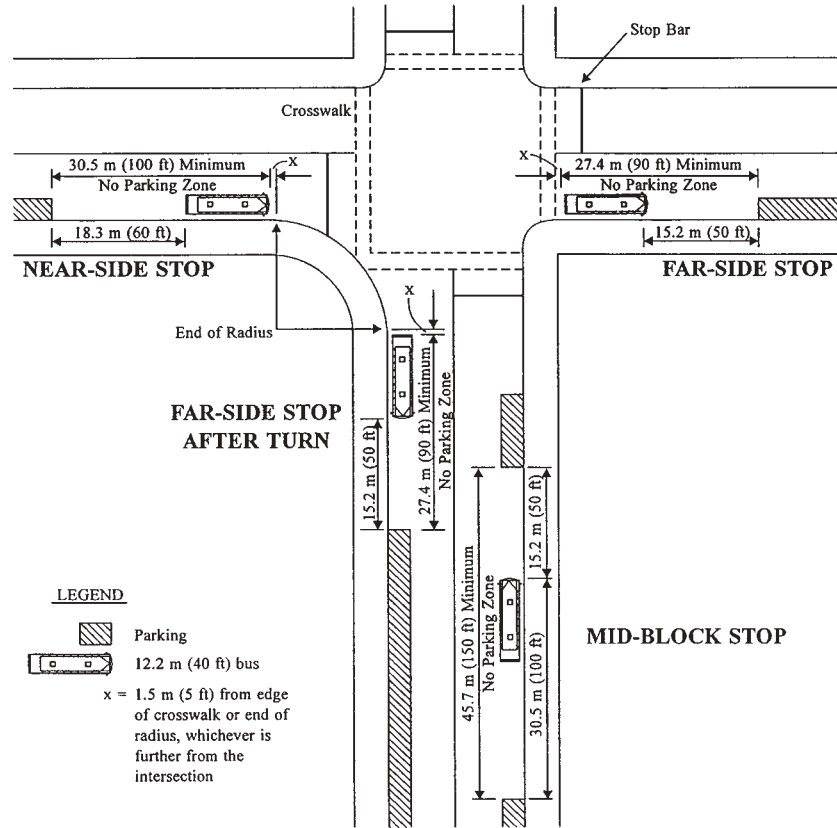
stop is preferable to minimize walking distances for transferring passengers.

Under all configurations, the use of extended curbs, or bus bulbs, (as shown in Figure 5-10) should be considered to simplify the approach to and departure from the platform. Use of these kinds of curbs can improve ride quality for passengers and allow for curbside parking. Passenger facilities are, however, constrained by available sidewalk space. Shelters and street furniture should be placed where they minimize conflicts with pedestrian circulation. Stops should be paved, well drained, suitably illuminated, and connected to paved sidewalks.

Multiple-berth stops should be provided when bus flows are heavy. A peak flow rate of 60 buses per hour would require two loading positions for a 30-second stop and three loading positions for a 60-second stop. (See Appendix A.) An additional 50 feet for each regular bus and 70 feet for each articulated bus should be provided.

## 5-5. INTERMODAL AND TERMINAL STATIONS

Intermodal and terminal stations are essential complements to BRT running ways and on-line stations. They reinforce the effectiveness of BRT operations because they promote transfer between BRT and connecting bus lines, and they simplify



(SOURCE: Texas Transportation Institute, 1996)

Figure 5-9. Curbside bus stops.

both BRT and local bus service patterns. Large terminals in urban areas may provide intermodal connections to other modes such as LRT and heavy rail. At the smaller end of the BRT application continuum, terminals and bus-to-bus transfers may be simple, in-street activity. However, most BRT systems employ some type of specialized off-street intermodal stations and/or terminals. These range from smaller facilities with fewer than five bus bays to massive urban terminals with hundreds of berths.

Site-planning fundamentals for intermodal stations and terminals are the following:

- Site planning should separate BRT, feeder bus, and private automobile traffic as much as possible, with the highest priority given to direct BRT access.
- Intermodal transfer and/or park-and-ride facilities may be placed on one or both sides of the BRT line, but it is best to favor the “inbound” side of the BRT line relative to the city center.
- Site design should minimize walking distances and bus-pedestrian conflicts for transferring passengers.
- The following location priorities should be observed in terms of proximity to the BRT passenger loading area: (1) pedestrian arrivals, including ADAAG-accessible

route(s); (2) bicycles; (3) feeder buses; (4) kiss-and-ride, short-term parking, and motorcycles; (5) taxis and HOVs; and (6) park-and-ride, or long-term parking.

- Long-term parking may be provided at intermodal stations and terminals as an alternative to excessive feeder bus service in low-density residential areas (refer to Section 5-6 for additional information and planning data).

Planning guidance for BRT and feeder bus platforms in intermodal stations and terminals is summarized as follows:

- At terminals, shallow sawtooth berths are usually desirable to allow independent bus entry and exit. As for all stations, close coordination with operations planners is essential to ensure that the facility functions effectively.
- Adequate space for bus layover and short-term bus storage must be provided.
- As a rule of thumb, it should be assumed that one berth is required for each six buses per hour. Capacities may be greater when there is free transfer between BRT and connecting bus lines. There should not be more than two to three connecting services per boarding berth. This may increase the number of boarding positions required.

**TABLE 5-3 Advantages and disadvantages of near-side, far-side, and midblock stops**

Location	Advantages	Disadvantages
Far-side	<ul style="list-style-type: none"> <li>▪ Minimizes conflicts between right-turning vehicles and buses</li> <li>▪ Provides additional right-turn capacity by making curb lane available for traffic</li> <li>▪ Minimizes sight distance problems on intersection approaches</li> <li>▪ May encourage pedestrians to cross behind the bus, depending on distance from intersection</li> <li>▪ Creates shorter deceleration distances for buses, since the intersection can be used to decelerate</li> <li>▪ Buses can take advantage of gaps in traffic flow created at signalized intersections</li> <li>▪ Facilitates bus signal priority operation, as buses can pass through intersection before stopping</li> </ul>	<ul style="list-style-type: none"> <li>▪ May result in intersections being blocked during peak periods by stopped buses</li> <li>▪ May obscure sight distance for crossing vehicles</li> <li>▪ May increase sight distance problems for crossing pedestrians</li> <li>▪ Can cause a bus to stop far-side after stopping for a red light, interfering with both bus operations and all other traffic</li> <li>▪ May increase the number of rear-end crashes since drivers do not expect buses to stop again after stopping at a red light</li> <li>▪ Could result in traffic queued into intersection when a bus stops in the travel lane</li> </ul>
Near-side	<ul style="list-style-type: none"> <li>▪ Minimizes interference when traffic is heavy on the far side of the intersection</li> <li>▪ Allows passengers to access buses close to crosswalk</li> <li>▪ Intersection width available for bus to pull away from the curb</li> <li>▪ Eliminates the potential for double-stopping</li> <li>▪ Allows passengers to board and alight while stopped for red light</li> <li>▪ Allows drivers to look for oncoming traffic, including other buses with potential passengers</li> </ul>	<ul style="list-style-type: none"> <li>▪ Increases conflicts with right-turning vehicles</li> <li>▪ May result in stopped buses obscuring curbside traffic control devices and crossing pedestrians</li> <li>▪ May cause sight distance to be obscured for side street vehicles stopped to the right of the bus</li> <li>▪ Increases sight distance problems for crossing pedestrians</li> <li>▪ Complicates bus signal priority operation, may reduce effectiveness or require a special queue-jump signal if the stop is located in the parking lane or a right-turn lane</li> </ul>
Midblock	<ul style="list-style-type: none"> <li>▪ Minimizes sight distance problems for vehicles and pedestrians</li> <li>▪ May result in passenger waiting areas experiencing less pedestrian congestion</li> </ul>	<ul style="list-style-type: none"> <li>▪ Requires additional distance for no-parking restrictions</li> <li>▪ Encourages passengers to cross street mid-block (jaywalking)</li> <li>▪ Increases walking distance for passengers crossing at intersections</li> </ul>

SOURCE: Texas Transportation Institute, 1996 (adapted).

- Buses may unload and load at the same location when space is constrained or bus volumes are light. Higher-volume operations may require separate unloading and loading areas. In these arrangements, buses (1) unload, (2) pass through a holding area as needed, and (3) then proceed to a loading berth for passenger boarding.

**5-5.1. Intermodal Stations**

Interchange facilities should be provided whenever local bus lines cross or meet at BRT stations or terminals. Whenever possible, off-street transfer facilities should be provided, particularly when multiple feeder bus bays are required. However, if some feeder buses serve the station without terminating, these berths may best remain in the street. When BRT

operates along dedicated and/or grade-separated busways, there are two basic configurations. The first is conventional on- or off-street bays adjacent to the busway station. (Figure 5-3 shows an application with off-street bays.) The second configuration (for higher-volume applications) may use shared platforms or grade-separated facilities to minimize walking distances for transferring passengers. Two potential configurations are shown in Figure 5-11.

**5-5.2. BRT Terminal Stations**

Terminal stations may be either on line or off line, depending on the BRT route(s) being served. All terminal stations require adequate space for a turning loop for buses. Passenger-oriented retail such as newsstands, food and beverage services,

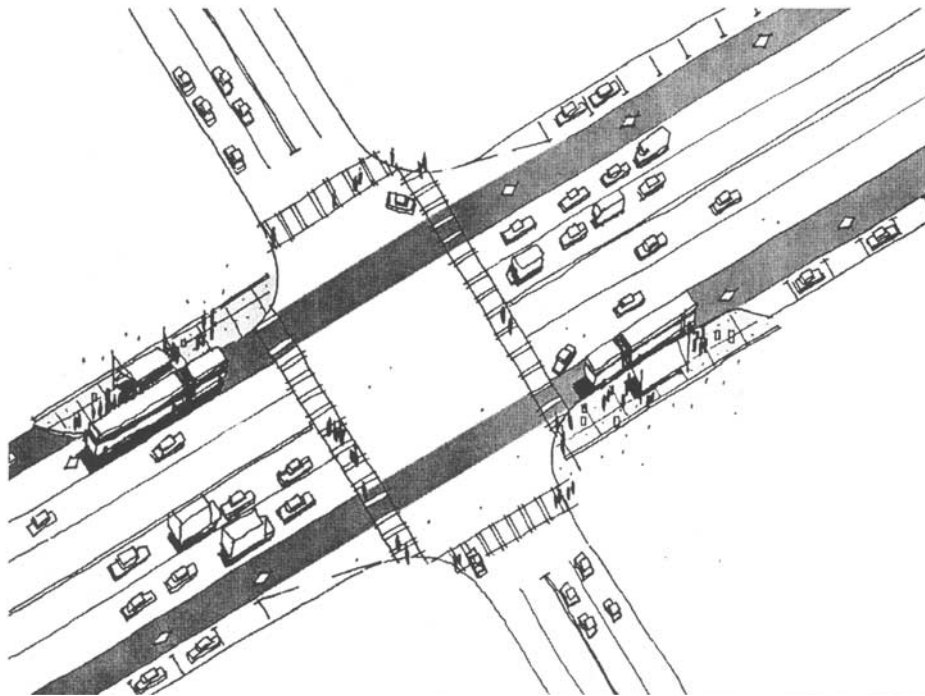


Figure 5-10. Far-side curbside sketch.

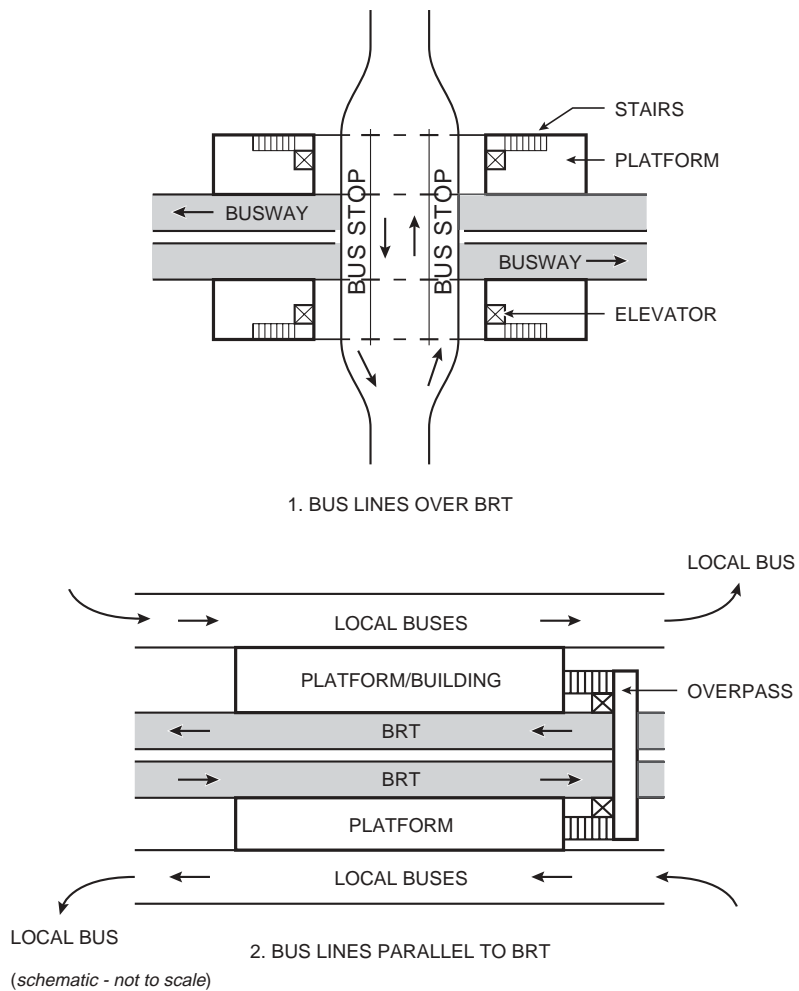


Figure 5-11. BRT transfer station concepts.

and drycleaners are highly desirable at BRT terminals. Figure 5-12 shows a typical on-line terminal station. Off-street bus transfer stations (or “transit centers”) are usually found in areas located about 4 to 10 miles from the city center. Their size will depend on the number of connecting routes served and the likely interchanging passenger flow. Figure 5-13 shows a design for a small, off-line terminal facility that incorporates a small enclosed pavilion for retail and passenger waiting.

#### 5-5.2.1. Central Area Terminals

Very large central area bus terminals for commuter or express bus services may be appropriate when there is good access to the central area, but there is extensive local street congestion within the area; when the terminal is located within a short walking distance of major employment concentrations; and when there is good supporting transit service to other areas. The most successful facilities offer direct connections to expressways and are located on the edge of the CBD core, close to major employment centers (but removed from peak land values). Under these circumstances, central terminals can productively serve peak-period express BRT. Examples of this type of facility are the Port Authority of New York and New Jersey’s 225-berth terminal in Manhattan, San Francisco’s 37-berth Transbay Bus Terminal, and the Massachusetts Bay Transportation Authority’s (MBTA’s) 54-berth South Station Bus Terminal in Boston (shown in Photo 5-F).

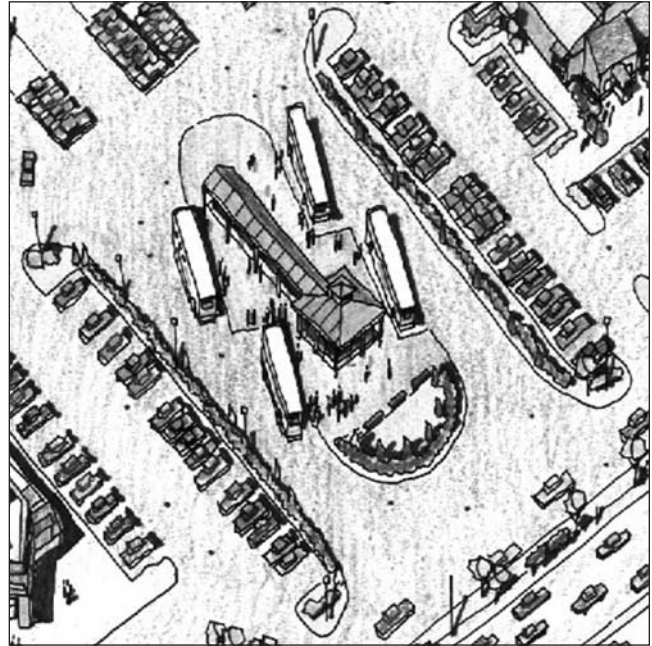
Although central terminals work well for express service, they are not as well suited to high-frequency BRT operations. The disadvantages include high capital and operating costs; longer dwell and maneuvering times for buses; inability to provide through BRT service, which results in forced transfers; greater walking distances for many passengers; and increased bus-to-bus congestion on terminal approaches. Therefore, BRT service is usually better served by having buses remain on CBD streets and busways.

## 5-6. PARK-AND-RIDE FACILITIES

Park-and-ride facilities should be provided at BRT stations when a large number of potential riders are located beyond



Figure 5-12. Typical on-line terminal station.



(Illustration Credit: Keith Hudson, AIA)

Figure 5-13. Small off-line terminal station.

easy walking distance of stations, or when riders cannot be served effectively by connecting bus services. Park-and-ride facilities are generally associated with suburban areas and mainly serve commuters, although some settings may generate off-peak demands as well. Park-and-ride facilities should save BRT passengers travel time and simultaneously expand the service catchment area. The secondary distribution by automobile (1) expands the BRT market, (2) reduces the need for feeder bus service, and (3) permits wider BRT station spacings. Park-and-ride facilities are most successful when free or low-cost parking is offered, peak-hour BRT service headways are 10 minutes or less, and BRT trips to the city center save at least 5 minutes of travel time. Free park-and-ride facilities may be offered to BRT patrons, park-and-ride fees may be incorporated into the BRT fare, or park-and-ride facilities may be separately priced. Outlying parking is likely to be more economical than local feeder bus service when land costs are low and travel distances to line-haul bus service are long. Some issues to consider in relation to park-and-ride facilities are the following:

- *Location.* Park-and-ride facilities should be accessible, visible, and located where future expansion is possible. They should be sited in areas that are compatible with significant open spaces or large structures. They should have good road access from major cross-town and circumferential roads and be located where they can intercept motorists before points of congestion or road convergence. Sites should be selected to minimize backtracking, as most patrons approach from the far or outbound end of stations.



Photo 5-F. MBTA South Station Intermodal Center.

- Size.** The number of park-and-ride spaces should be keyed to projected station ridership. Experience with commuter rail and rail rapid-transit lines indicates that ridership is sometimes constrained by the lack of parking spaces. A parking space should be provided for every 1.2 to 5.0 boarding BRT passengers, depending on the number of feeder/connecting bus services. It is desirable to provide 10 to 15% more spaces to ensure space availability. Land acquisition requirements should be based on 125 spaces per acre (about 400 to 450 square feet per space). To keep walking distances under 400 to 600 feet, surface parking lot size should not exceed 800 spaces, although facilities of 1,200 to 1,500 spaces can be accommodated in special cases. When more than 800 spaces are required, structured parking should be considered to keep walking distances short. About 1 to 3% of the total spaces should be designated for short-term parking. These spaces should be clearly separated from commuter parking areas, but they could be used for mid-day parking if properly controlled.
- Site-planning considerations.** Park-and-ride facilities should provide direct, convenient pedestrian access to BRT stations. As with intermodal stations, they should provide convenient passenger drop-off, or “kiss-and-

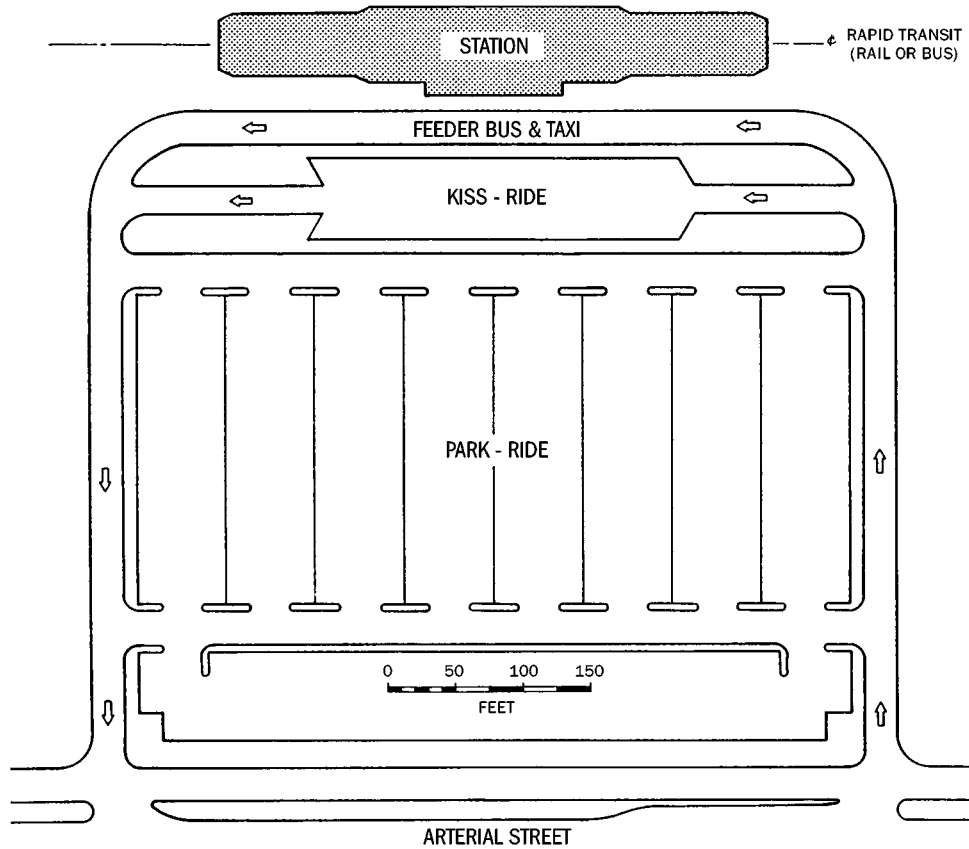
ride,” space and accommodate most traffic in two short peaks. Facility site planning should minimize conflicts among buses, automobiles, and pedestrians. Separate access points for buses and automobiles are desirable when parking facilities exceed 500 spaces or when parking fees are charged. A site plan for a prototypical park-and-ride facility is shown in Figure 5-14.

## 5-7. ANCILLARY FACILITIES

Ancillary facilities associated with BRT systems include operator welfare facilities, vehicle maintenance and storage facilities, and maintenance of way facilities. Frequently, most or all of these functions are consolidated at a single site.

**Operator welfare facilities** range widely in size and complexity. The smallest facilities may simply provide an operator toilet room at the outbound end of a route, whereas larger ones would provide amenities such as showers, lockers, canteens and lunchrooms, and “quiet rooms” for resting between shifts. The largest facilities include space for operator training, administrators, supervisory personnel, and dispatchers. Typically, all of these facilities are co-located with a terminal station or a maintenance and storage facility.





(SOURCE: Levinson et al., 1975)

Figure 5-14. Prototype park-and-ride plan.

**Maintenance and storage facilities (MSFs)** are very large, multiple-building complexes where vehicles are maintained and stored. Even if a transit agency already operates one or more maintenance facilities for its buses, a BRT system is likely to have a significant fleet of vehicles that exceed the capacity of existing facilities. Also, a BRT fleet may use dedicated, specialty vehicles (e.g., articulated buses) that require space and equipment not required for existing fleets of conventional buses.

MSFs occupy large land areas and tend to generate concentrated morning and evening bus traffic. They are most compatible with industrial uses and other large-scale developments. To the extent feasible, they should be sited to avoid sensitive receptors. However, it is important to note that with sensitive planning and design these facilities can be successfully integrated with residential and other uses.

In conventional bus systems, it is ideal to site the MSF near the center of the system's service area. However, depending on the character of the BRT service, a BRT MSF may be more likely to be found at the outbound end of a major route so that the vehicles are positioned to enter service in the morning.

The following are brief descriptions of major functions typically found at a BRT MSF:

- **Service Lanes.** These are semi-enclosed or covered areas used for daily servicing of buses including fueling, fluid dispensing, and interior and exterior cleaning. If on-board fare collection is used, the service lanes are also used for cash removal. Typically, the site is arranged so that buses enter the service lanes directly after leaving revenue service and prior to overnight storage. This program element should be provided at any facility where buses are stored overnight.
- **Maintenance Facility.** A maintenance facility provides space for routine maintenance and inspection. This facility should have provisions for maintenance bays, parts storage, tire storage, steam cleaning, and battery storage. It should also have a paint shop (including a preparation area and a paint booth), a shipping and receiving area, supervisors' and administrative offices, employee locker rooms, and toilet facilities.
- **Heavy Maintenance Facility.** A heavy maintenance facility is for activities such as engine and transmission rebuilds and major body work. Because these activities are less frequent and therefore are more likely to be outsourced or shared with existing facilities, a heavy maintenance operation is not always present in a BRT MSF. When present, such a facility is likely to include a machine

shop as well as shop areas for electrical work, radiators, transmissions, woodworking, upholstery, welding, metalworking, graphics, thermal cleaning, and glass working. This facility would also include a shipping and receiving area, a storage room, a lunchroom, lockers, and toilet facilities.

- *Bus Storage.* Storage of buses requires large exterior spaces. The size of the storage area is strongly influenced by the bus parking configuration. System operators are likely to prefer a “scheduled pullout” arrangement, similar to a traditional parking lot, in which all buses are parked adjacent to a driving lane, and any bus can be accessed at any time. Ideally, angled spaces are used in single rows as shown in Figure 5-15, permitting buses to enter and leave a space without backing up. A more space-efficient “herringbone” pattern can be used, but

this requires buses to back up to depart. The scheduled-pullout arrangement offers the operator the greatest flexibility for dispatching or maintenance, but it occupies the greatest amount of space.

When space is limited, a “stacked” arrangement may be used, in which multiple buses are parked bumper to bumper. Although not as flexible as the scheduled-pullout arrangement, the same number of vehicles can be stored in as little as one-third of the space.

In North America, all facilities, parking, and bus storage areas should be arranged to accommodate left-hand turns and a counter-clockwise site circulation. Figure 5-15 shows a prototypical MSF site plan.

- *Maintenance of Way Facilities.* These facilities are for personnel and equipment used to maintain stations and running ways. This function may be minor (and readily

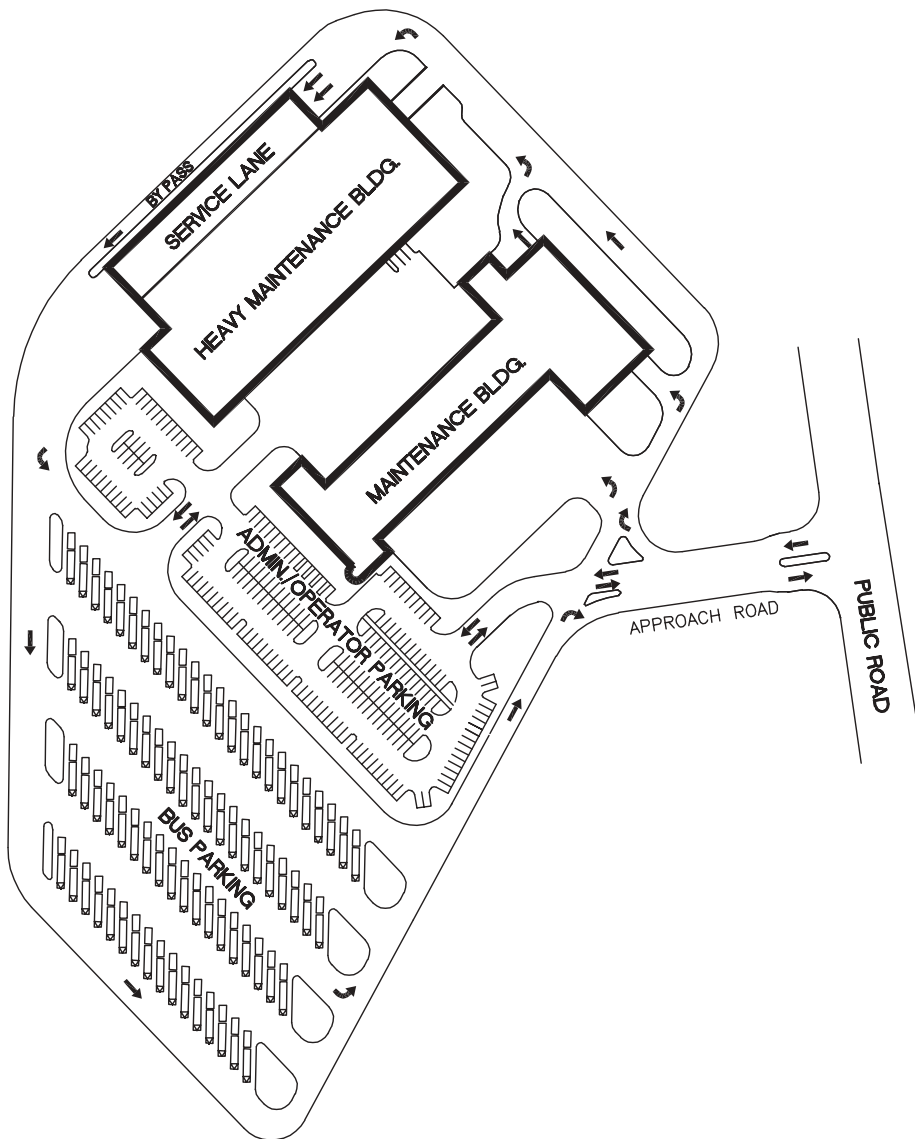


Figure 5-15. Illustrative maintenance and facilities site plan.

located with other municipal facilities) if the BRT system runs in the street with relatively small station facilities. However, a grade-separated BRT system with large stations is likely to require maintenance shops and dedicated equipment such as tow trucks, snowplows, and crew transportation.

## 5-8. CHAPTER 5 REFERENCES

- Americans with Disabilities Act Accessibility Guidelines*. The Access Board, Washington, DC (September, 2002). [www.access-board.gov/adaag/htm/adaag.html](http://www.access-board.gov/adaag/htm/adaag.html).
- Fruin, J. J. *Pedestrian Planning and Design*. Elevator World, Mobile, AL (1987).
- Fuhs, C. A. *High-Occupancy Vehicle Facilities: A Planning, Design, and Operation Manual*. Parsons Brinckerhoff Quade & Douglas, Inc., New York, NY (1990).
- Guide for the Design of Park-and-Ride Facilities*. American Association of State Highway and Transportation Officials, Washington, DC (1992).
- Kittelson and Associates, Inc. *TCRP Web Document 6: Transit Capacity Manual and Quality of Service Manual* (1st ed.). Transportation Research Board, National Research Council, Washington, DC (1999).
- Levinson, H. S., C. L. Adams, and W. F. Hoey. *NCHRP Report 155: Bus Use of Highways: Planning and Design Guidelines*. Transportation Research Board, National Research Council, Washington DC (1975).
- Levinson, H., S. Zimmerman, J. Clinger, S. Rutherford, R. L. Smith, J. Cracknell, and R. Soberman. *TCRP Report 90: Bus Rapid Transit, Volume 1: Case Studies in Bus Rapid Transit*. Transportation Research Board of the National Academies, Washington, DC (2003).
- Parsons Brinckerhoff Quade & Douglas. "NCHRP Project 20-7 (Task 135): Geometric Design Guide for Transit Facilities on Highways and Streets—Phase I Interim Guide." Transportation Research Board, National Research Council, Washington DC (2002).
- Pline, J. L. (ed.). *Traffic Engineering Handbook* (5th ed.). Institute of Transportation Engineers, Washington, DC (1999).
- Texas Transportation Institute, Parsons Brinckerhoff Quade & Douglas, and Pacific Rim Resources, Inc. *NCHRP Report 414: HOV Systems Manual*. Transportation Research Board, National Research Council, Washington DC (1998).
- Texas Transportation Institute. *TCRP Report 19: Guidelines for the Location and Design of Bus Stops*. Transportation Research Board, National Research Council, Washington, DC (1996).
- Value of Public Roadway Lighting*. Illuminating Engineering Society of North America, New York, NY (1987).
-

## CHAPTER 6

### BRT VEHICLES

BRT vehicles must be carefully planned and selected for a variety of reasons. Vehicles have a strong impact on every aspect of transit system performance, from ridership attraction to operating and maintenance costs. Vehicle design will have a strong, measurable impact on revenue speed and reliability and thus on ridership and related benefits such as congestion reductions, air quality improvements, and revenue enhancements. A vehicle's mechanical attributes have an obvious impact on operating and maintenance costs. However, proper door and interior design (e.g., a low floor, a wide aisle, and multiple-stream doors) may reduce dwell times and revenue speeds sufficiently to reduce the number of vehicles, drivers, and mechanics necessary to provide a particular level of service, as well as increasing ridership and revenue.

As the BRT element most widely observed by both users and potential customers, vehicle design also impacts perceptions of the quality of the entire system. Bus noise, air emissions, state of repair, cleanliness, and aesthetics all affect public perceptions of BRT. Although not as important as time and cost in effecting mode choice, image and “branding” influence the willingness of customers to try a BRT system, particularly those customers with the choice of using a private automobile instead. System branding and identity, as provided by vehicles, can also convey important customer information such as routing and stations served.

A unique vehicle identity for a particular BRT service, achieved through livery (e.g., paint schemes and colors) and/or design, not only advertises the system, but also tells the large number of infrequent customers (perhaps 35 to 40% of overall ridership on rapid transit) where they can board that service. Vehicle design can complement maps, signs, and other information sources, further enhancing transit ridership.

BRT vehicles should be environmentally friendly in terms of air and noise emissions and vibration. BRT services are frequent by definition, with the requirement that they have a basic peak headway low enough to support random passenger arrivals. Some transitways that serve a number of routes may have as many as 150 to 200 buses per hour using certain sections, particularly near CBDs (e.g., Pittsburgh, Miami, Brisbane, and Ottawa). With a level of service that is this frequent, special care must be taken to ensure that the

vehicles have low air as well as noise emissions. Low noise levels are desirable not only on board, where too much noise may affect customers' sense of travel quality and hence ridership, but also off board, in the vicinity of stations and running ways.

The importance of these technical and “soft” vehicle factors in the overall success of BRT systems has led an increasing number of manufacturers in both Europe and North America to develop specialized vehicles for BRT applications. These vehicles generally feature a distinct appearance (almost like an LRT vehicle) to create a unique, non-bus identity. BRT vehicles also can include some form of guidance (e.g., mechanical, optical, or magnetic) to increase passenger comfort and convenience. These vehicles may also possess a hybrid thermal engine electric propulsion system for environmental friendliness and an interior layout and door configuration to efficiently serve the intense markets carried by rapid-transit systems. Photos 6-A and 6-B are examples of the class of specialized BRT vehicles having all these attributes.

#### 6-1. CAPACITY AND LEVEL OF SERVICE

For BRT to be successful, as with any rapid-transit investment, the disparate elements of the system, including vehicles, must work together as an integrated whole. BRT vehicles should be planned and designed in accordance with the characteristics of the other elements of the system, including running ways, stations, service plans, ITS applications, and fare collection. Therefore, it follows that BRT vehicle characteristics are both inputs and outputs of an iterative planning and project development process. Vehicle characteristics affect overall levels of service in terms of speed, reliability, capacity, and cost and include the following:

- Dimensions,
- Internal Layout,
- Doors,
- Aisle Width,
- Floor Height and Flatness,
- Propulsion System,
- Guidance, and
- Image and Identity.



(Photo Credit: Irisbus of North America)

*Photo 6-A. Irisbus Civis configured for the North Las Vegas Boulevard corridor, Las Vegas, NV.*

Appendix E contains further technical details on BRT vehicle characteristics.

### 6-1.1. General Guidelines

The following guidelines should underpin the development of BRT vehicle specifications during planning and project development:

- Vehicles should be planned and ultimately specified as a function of the type of services offered (e.g., local versus express, and/or mixed) and the nature of the markets served (e.g., short, non-work, non-home-related trips versus long home-to-work trips). Criteria will include lengths and widths (standard industry dimensions) and internal layout. Internal layout includes seats (number, size, type, configuration and orientation); wheelchair positions (number, position and orientation); and propulsion systems (power, torque, noise, air emissions, top end speed, and acceleration).
- Vehicles should provide sufficient passenger capacity at comfortable loading standards for anticipated ridership



(Photo Credit: Bombardier)

*Photo 6-B. Bombardier's GLT "tram on tires" in operation in Nancy, France.*

levels and planned service structure and frequencies. Vehicles ranging in length from 12.2 to 13.75 meters (40 to 45 feet) (single unit) through 25.5 meters (82 feet) (double articulated) are in successful revenue service and can be considered.

- Vehicles should be environmentally friendly, easy and convenient to use, comfortable, and have high passenger appeal. Desirable features include air conditioning, bright lighting, panoramic windows, and real-time visual and audio "next stop" passenger information.
- Boarding and lighting vehicles should be easy and rapid. Floor heights less than 38 centimeters (15 inches) above pavement level are desirable unless technologies permitting level boarding and alighting (e.g., rapidly deployed ramps/bridges) are to be used at high-platform stations (as in Curitiba, Bogotá and Quito).
- A sufficient number of doors of sufficient width should be provided, especially when off-board fare collection is provided. Generally, one door channel should be provided for each 10 feet of vehicle length. Vehicles with doors on either or both sides are available and can enable use of both side and/or center platform stations.
- Ride quality is important for vehicles in BRT service because it contributes to the overall sense of quality, especially BRT services carrying large numbers of standees. Electric drive systems are being used increasingly for specialized BRT vehicles because they eliminate hydraulic-mechanical transmissions that often have abrupt shifting.
- The mix of space devoted to standing riders and seated riders will depend on the nature of the market served. All things being equal, total capacity is higher when the number of seats is lower, but most operators try to avoid having customers standing for more than 20 to 30 minutes.
- Wide aisles and sufficient circulation space can lower dwell times and increase the amount of capacity that is actually used, especially at the rear of articulated vehicles. Specialized low-floor BRT vehicles with aisle widths up to 86 centimeters (34 inches) are available.
- Cost-effective bus propulsion systems are available that virtually eliminate particulate emissions and are otherwise environmentally friendly as well. These include "clean diesel" with self-cleaning catalytic converters, various types of hybrids featuring both internal combustion engines and electric motors, and CNG-fueled spark ignition internal combustion engines. These propulsion systems not only have significantly reduced emissions compared with older diesel engines, but they are significantly quieter and can have high acceleration rates as well.
- Given the intensity of BRT services and their importance to the overall performance of the transit systems that have them, BRT vehicles should be well proven in revenue service, with lower than average mean distances between service-interrupting failures.

**TABLE 6-1 Typical U.S. and Canadian BRT vehicle dimensions and capacities**

Length	Width	Floor Height	Number of Door Channels	Number of Seats (including seats in wheelchair tie-down areas)	Maximum Capacity (seated plus standing)
40 ft (12.2 m)	96–102 in. (2.45–2.6 m)	13–36 in. (33–92 cm)	2–5	35–44	50–60
45 ft (13.8 m)	96–102 in. (2.45–2.6 m)	13–36 in. (33–92 cm)	2–5	35–52	60–70
60 ft (18 m)	98–102 in. (2.5–2.6 m)	13–36 in. (33–92 cm)	4–7	31–65	80–90
80 ft (24 m)	98–102 in. (2.5–2.6 m)	13–36 in. (33–92 cm)	7–9	40–70	110–130

- Guidance systems, both mechanical and electronic, are available that can impart rail-like passenger boarding and alighting service at stations, reduce right-of-way requirements, and provide a more comfortable ride than vehicles that can only be steered.
- Cost should be considered on a life-cycle basis because some of the features that add to initial acquisition costs (e.g., guidance, hybrid drives, stainless steel frames, and composite bodies) have the potential to reduce ongoing operating costs and increase passenger revenue. Some specialized BRT vehicles also purportedly have longer design lives than conventional equipment (e.g., 20 years versus 12 years without major structural overhaul).

#### 6-1.1.1. Dimensions

The basic dimensions of BRT vehicles, including weights, are limited in most places by the motor vehicle laws of the respective states and local jurisdictions for vehicles operating on the highway system. Vehicles may not be more than 2.6 meters wide (102 inches) and 18 meters (60 feet) long or have a gross vehicle weight of more than 7,273 kilograms (16,000 pounds) per axle. Although waivers can be obtained (e.g., for double articulated vehicles, which are shorter than many legal two-trailer, tractor-trailer combinations), most buses and BRT vehicles fall within this relatively tight envelope. The approximate dimensions of this envelope for actual vehicles are shown in Table 6-1. The table also contains basic information on floor height, door channels, range in number of seats, and maximum capacities for service planning purposes. Typically, buses have an overall height from the pavement of 3.4 meters (11 feet), whereas low-floor CNG buses with storage tanks on the roof can be up to 4.6 meters (15 feet) high.

Photo 6-C shows a conventional low-floor bus from the Los Angeles Metro Rapid system. Photo 6-D presents a composite 13.8-meter (45-foot) low-floor bus, and Photo 6-E shows a conventional low-floor articulated bus used on the Vancouver #98 B-line. Photo 6-F contains a conventional

24-meter (80-foot) double articulated low-floor bus of the type increasingly being used for rapid-transit services in Europe (e.g., in Amsterdam, Netherlands, and Nancy, France) and South America (e.g., Curitiba).

#### 6-1.1.2. Seats and Standee Density

The capacity of BRT vehicles equals the number of seats plus the number of standees, at a density standard consistent with the service plan, nature of the market carried, and the operating environment. According to the Transportation Research Board's *Transit Capacity and Quality of Service Manual* (Kittelson and Associates, Inc., et. al, 1999), a typical urban transit seat occupies approximately 0.5 square meters (5.4 square feet, 18-inch width by 27-inch pitch). Average standee density over an average peak hour, as specified by the International Union of Public Transport (UITP), is four people per square meter or approximately 2.7 square feet per person. FTA guidance has been to use a consistent maximum of three standees per square meter (3.7 square feet



(Photo Credit: Los Angeles County Metropolitan Transportation Authority)

*Photo 6-C. North American Bus Industries conventional low-floor bus—12.2-meter (40-foot), low floor, CNG (Metro Rapid Bus, Los Angeles, CA).*



(Photo Credit: North American Bus Industries)

*Photo 6-D. Composite 13.8-meter (45-foot) low-floor bus.*

per person) in alternatives analyses/major investment studies for all modes.

These densities apply for typical urban service in which riders stand less than a policy-specified length of time, usually 20 to 30 minutes. John Fruin's book, *Pedestrian Planning and Design* (1987) shows that at a density of three people per square meter, no customer will be touching another customer anywhere, and perhaps most importantly, there will be sufficient room for customers to circulate freely.

The three standees per square meter density standard serves to ensure an even distribution of passengers throughout the BRT vehicle and serves to minimize dwell times at stops. This standee density is an average over a typical peak hour within a typical peak period. The density (defining "crush" capacity) during the peak of the peak hour, usually 15 minutes, would be about 40% higher, or about 4.2 people per square meter in U.S. practice.

The number of seats is also very much influenced by the number and placement of doors and, on low-floor buses, intrusion into the vehicle interior of wheel wells, fuel tanks, and engines. When trip lengths are longer and people are likely



(Photo Credit: New Flyer of Canada, Ltd.)

*Photo 6-E. New Flyer conventional low-floor bus—18-meter (60-foot) low-floor articulated bus (Vancouver 98 B-line).*



(Photo Credit: Van Hool)

*Photo 6-F. Conventional low-floor bus—24-meter (80-foot), double articulated, low-floor.*

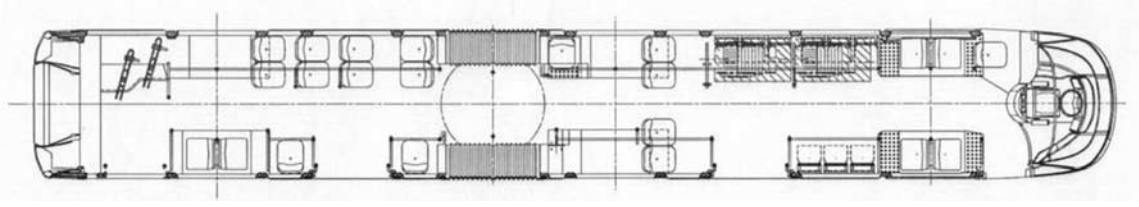
to be standing at or even beyond policy maximums (e.g., on longer "commuter express" routes operating on HOV lanes and/or transitways), a lower standee density may be appropriate. In some cases, when vehicles operate in mixed traffic at high speeds, it may be appropriate for safety reasons to preclude standees altogether.

Because BRT can be steered and guided, vehicles can operate in any running way environment. In mixed traffic on public streets and roads, the outside dimensions of BRT vehicles are relatively fixed. Width must be less than 2.6 meters (102 inches). Single-unit buses must be less than 12.2 to 13.75 meters (40 to 45 feet) long, single articulated vehicles less than 18.3 meters (60 feet) long and double articulated vehicles less than 25.5 meters (83 feet) long.

The mix of seating and standing areas in a given BRT vehicle should be a function of the characteristics of the market being served. Normal transit operating policies dictate that customers should not stand for more than a certain amount of time, typically between 20 and 30 minutes.

If most travelers are expected to be traveling longer than 20 to 30 minutes (e.g., in a BRT corridor anchored at one end in a traditional CBD and extending far into relatively low-density suburban areas), the given vehicle should be configured for the maximum number of seats. For typical low-floor buses, this is in the vicinity of 40 to 44 seats for a 12.2-meter (40-foot) low-floor vehicle, about 55 to 60 seats for a single articulated 18-meter (60-foot) low-floor vehicle, and 65 to 75 seats for a double articulated 24-meter (80-foot) vehicle. These values are based on the assumption that some of the seating capacity would be used for each wheelchair position (three seats per wheelchair position if the seats are of the peripheral, tilt-up variety) as required by ADA.

Some BRT applications involve dense urban corridors where trips are relatively short and where there is a significant amount of passenger turnover (e.g., North Las Vegas Boulevard). In these situations, more room will be given to standing areas than to seating areas for a couple of reasons. First, the



(Illustration Credit: Irisbus North America)

*Figure 6-1. Floor plan for 18-meter (60-foot) Las Vegas Boulevard Irisbus Civism BRT vehicle, configured for dense urban corridor with significant turnover and relatively short trips.*

smaller number of seats maximizes the total capacity available from the same vehicle envelope because seated customers occupy more space than standees. Second, having fewer seats provides a more open interior with better circulation characteristics. Seats installed perpendicular to vehicle walls not only reduce the area available for standees, but they also make circulation within the vehicle more difficult, especially near doors.

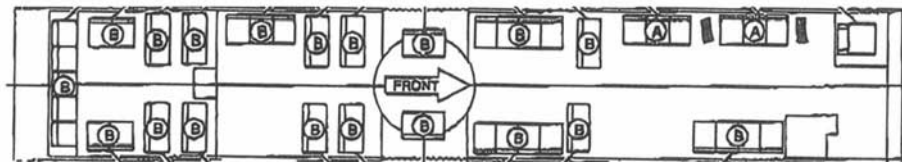
Constrained circulation within the vehicle has the net effect of increasing passenger service times at stops because it makes it difficult for people in the interior of the vehicle to get off, and it makes it difficult for boarding passengers to circulate to the vehicle's interior, causing crowding around the doors and reducing useful capacity. For these reasons, some BRT applications in high-density corridors with significant passenger turnover and relatively short trips (e.g., Las Vegas Boulevard and Rouen, France), use vehicles with large open standing areas rather than seats around their doors (see floor plans in Figures 6-1 and 6-2). The maximum capacities shown are approximations based on the vehicle dimensions shown in the table. Maximum capacities are computed as the number of seats plus a number of standees calculated using a standing area divided by a standing density. (See Kittelson and Associates et al., 1999, Chapter 3, Section 4, for details.)

The numbers shown assume a standee density of three standees per square meter on average over the peak hour (approximately 3.7 square feet per person) as typical in U.S. rapid-transit service planning practice. The dimensions of specific vehicles are shown in Appendix E, in Table E-1.

### 6-1.1.3. Doors

When fares are collected off board (and even when they are not), the larger the number and the width of doors, the lower passenger service times will be. Multiple doors can also result in a better distribution of passengers within the vehicle, thus taking full advantage of available capacity. Each boarding and alighting stream using a double stream door should be allocated at least 51 centimeters (20 inches) or more of door width, with at least 76 centimeters (30 inches) for a single channel door. The single stream door minimum width is dictated by ADA-mandated wheelchair accessibility. In markets with a significant amount of simultaneous boarding and alighting, the maximum number of double stream doors of at least a 1.07- to 1.22-meter (42- to 48-inch) width will be important for reducing passenger service times.

A given vehicle cannot have the maximum number of double stream doors (e.g., up to three on a 12.2-meter [40-foot] vehicle and up to four on an 18-meter [60-foot] vehicle) and still have the maximum number of seats, because seats are always tied to the outside wall of a vehicle. The floor plan for the Las Vegas vehicle (shown in Figure 6-1), to be used in a dense urban corridor with significant turnover, illustrates the trade-off between the number of doors (4) and the number of seats (32). This can be compared with the schematic for the standard articulated bus shown in Figure 6-2, which is used on Ottawa Transitway system. The vehicle shown in Figure 6-2 has almost identical dimensions, but it has 54 seats and only 3 doors (2 double stream doors and 1 single door). The



(Illustration Credit: New Flyer of Canada, Ltd.)

*Figure 6-2. Floor plan for 18-meter (60-foot) Ottawa Transitway low-floor New Flyer bus, configured for typical radial corridor extending to suburbs from CBD.*





(Photo Credit: TransMilenio website)

*Photo 6-G. BRT vehicle with several multiple-stream doors to facilitate rapid boarding/alighting in corridor with metro rail levels of demand (TransMilenio system, Bogotá, Colombia).*

area around the doors on the Las Vegas vehicle is much clearer than it is on the Ottawa vehicle, easing circulation. Although both vehicles have essentially the same external dimensions, one has 7 boarding/alighting streams and 32 seats whereas the other has 5 streams and 54 seats.

Photo 6-G illustrates a vehicle on the Bogotá TransMilenio system, which is used in a corridor with metro rail levels of demand (i.e., over 27,000 riders per hour.) This photo illustrates the use of several multiple-stream doors to facilitate rapid boarding and alighting for what is arguably the busiest BRT system with on-line stops in the world.

*6-1.1.3.1. Number of Doors*

A U.S. “rule of thumb” for the number of boarding and alighting channels appears to be that there be at least one channel per 10 feet of BRT vehicle length in corridors that

run radially from a dense urban core to lower-density suburbs. For dense corridors, in which significant boarding and alighting take place simultaneously, a larger number of passenger service streams in the same vehicle length may be warranted. For an express operation, in which everyone alights in the a.m. peak and boards in the p.m. peak at a limited number of all-boarding or all-alighting stops, somewhat fewer channels may be appropriate.

A number of conventional buses and specialized vehicles are available with doors on either the left side (e.g., as in Bogotá and Curitiba) or both sides. This is done to allow vehicles to use a center platform either exclusively, as in the South American systems, or in conjunction with side platform stations, as is planned in Cleveland. Center platform stations are popular for rapid-transit stations where right-of-way widths are tight at stations. Center platforms also reduce the need for multiple fare media vending machines and level-change devices such as elevators and escalators, and they make it easier to provide security.

The effects of door channels on boarding and alighting times are shown in Table 6-2. Increasing from one to two channels reduces boarding time 40%, from 2.5 to 1.5 seconds per passenger. Similar reductions are given for front and rear alighting. Photo 6-H shows a specialized BRT vehicle configured for a dense urban corridor with significant passenger turnover. The vehicle features seven passenger service streams (three double doors, one single) for an 18-meter (60-foot) vehicle.

*6-1.1.3.2. Door Positions*

The major objective affecting door positioning is the need to ensure even loading and unloading across the length of the respective vehicles. All things being equal, doors should be positioned to divide BRT vehicles into sections of roughly equal capacity and circulation distances. Two factors provide flexibility in this regard. First, BRT applications with off-board fare collection do not need to have a door positioned forward of the front axle for payment of cash fares to a driver. Second, certain 100%-low-floor

**TABLE 6-2 Passenger service times with multiple-channel passenger movements for a high-floor bus (seconds per passenger applied to the total number of passengers boarding at a given stop)**

Available Door Channels	Boarding <sup>1</sup>	Front Alighting	Rear Alighting
1	2.5	3.3	2.1
2	1.5	1.8	1.2
3	1.1	1.5	0.9
4	0.9	1.1	0.7
6	0.6	0.7	0.5

NOTE: Increase boarding times by 20% when standees are present. For low-floor buses, reduce boarding times by 20%, front alighting times by 15% and rear alighting times by 25%.

<sup>1</sup> All data assume off-board fare collection.

SOURCE: Kittelson and Associates, Inc., 2002.



(Photo Credit: Irisbus North America)

*Photo 6-H. 18-meter (60-foot) BRT vehicle configured with seven passenger service streams (three double doors, one single) for a dense urban corridor with significant passenger turnover.*

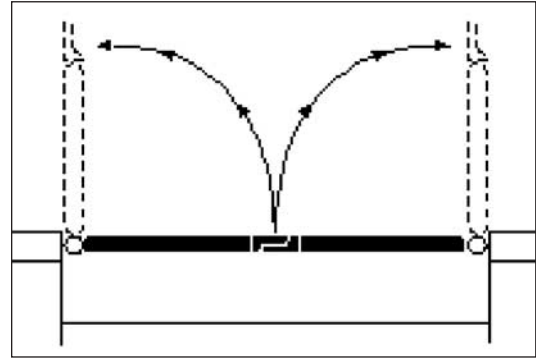
vehicles have the option of a door installed to the rear of the rear axle. Irrespective of how fares are collected, doors should be positioned and configured so that no single door (e.g., the front door) is disproportionately utilized because the result will be increased passenger service and dwell times.

#### 6-1.1.3.3. *Door Types*

Four basic types of doors are generally used for buses in North America: swing doors, bi-fold doors, plug doors, and pivot doors (sliding doors are used for buses in some other countries). Each type is described below along with an assessment of its applicability to BRT.

**Swing Doors.** These doors rotate around a vertical axis at the outer edge of the respective door panels and open outward to a position perpendicular to the vehicle at the outer edges of the respective door opening. Although they are simple to install and deploy, when used for wide, double stream doors in BRT applications, swing doors may keep the vehicle from being safely operated close to station platform edges. Figure 6-3 shows a schematic of swing doors.

**Bi-Fold Doors.** These doors, which hinge in the middle as well as at the outside vertical edges, are simple and have traditionally been used on streetcars and buses on which wide door openings were required. As such, they are ideal for BRT applications. The downside of this arrangement is that bi-fold doors may protrude outside the vehicle, limiting how close to platform edges a particular vehicle may come. The door panels themselves are usually rather narrow (i.e., one quarter the width of the door opening), limiting the amount of available window space (after the frames are accounted for) and light in the important door area during daylight hours. Figure 6-4 is a schematic of bi-fold doors.



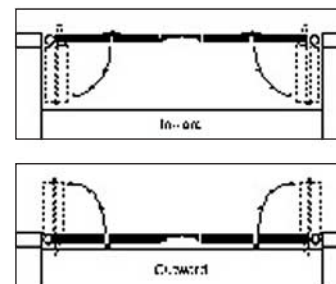
(Illustration Credit: North American Bus Industries)

*Figure 6-3. Swing Door.*

**Plug Doors.** Through a relatively complex hinge arrangement, plug doors swing outward and end up flush with the sides of the vehicle. They work well with wide door openings, which is why they are frequently used on airport apron passenger shuttle vehicles. Their downside is their complexity and potential maintenance problems. A schematic of plug doors is shown in Figure 6-5.

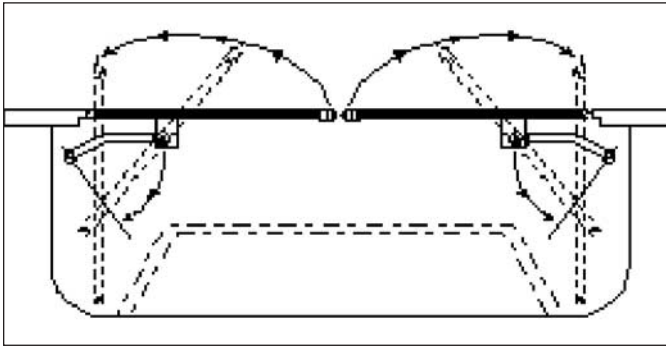
**Pivot Doors.** These doors rotate around a vertical axis that is interior to the door. They are frequently used in contemporary buses because of their relative simplicity. One of their disadvantages for BRT use is that it is difficult to use them for wide openings because they intrude into the vehicle when open, thus limiting standing space and creating a potential safety issue. Figure 6-6 provides a schematic of a pivot door.

**Sliding Doors.** These doors are generally only used for rail rapid-transit vehicles in the United States, although they are routinely used on buses carrying high loads in Japan and in other Asian countries that use Japanese buses. These doors are very effective where wide openings, in excess of 1.2 meters (4 feet), are needed because they can be opened with no internal or external protrusions. The downside of this arrangement for BRT applications is that their opening/closing mechanisms can be complex.



(Illustration Credit: North American Bus Industries)

*Figure 6-4. Bi-Fold Door.*



(Illustration Credit: North American Bus Industries)

Figure 6-5. Plug Doors.

The descriptions and assessments above suggest that bi-fold, pivot, and swing doors have the highest applicability to North American BRT systems.

6-1.1.4. Aisle Width, Floor Height, and Floor Flatness

Aisle width, floor height, and floor flatness also influence vehicle capacity. Most conventional low-floor vehicles, even those with a step up to the rear portion of the vehicle, have a minimum aisle width between the rear wheel wells (second and third axle on articulated vehicles) of about 60 centimeters (24 inches). The constraint is the width of the double bogie (two tires on either end of the axle), the geometry of the axle’s suspension system, and the need to clear drive train components.

Some specialized BRT vehicles have hub electric motors inside extra-wide, extra-strength tires. This arrangement, along with perimeter seating, allows for a wider aisle (minimum width of 87 centimeters [34 inches]), which in turn permits easier in-vehicle circulation, lower passenger service times, and reduced station dwell times. Larger aisle width, in addition to no-step boarding and alighting, is one of the reasons

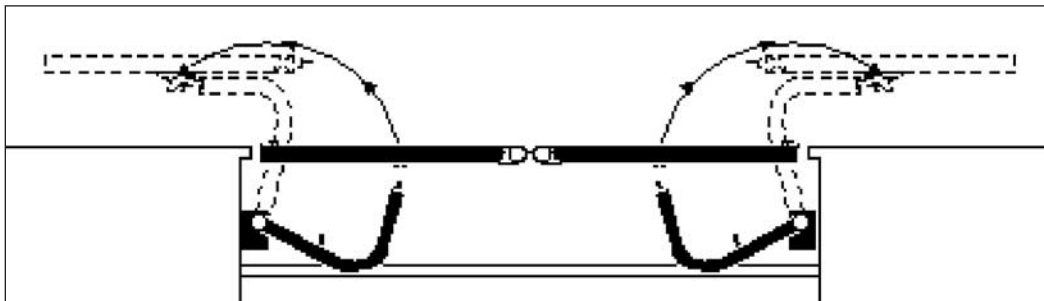
that heavy rail systems have passenger boarding and alighting times as low as 2 seconds per passenger. Boarding and alighting times for street running LRT, even where fares are paid off-board, are approximately 3 seconds per passenger.

Irrespective of running gear intrusion into the vehicle, when there is 2+2 perpendicular seating, aisle width cannot be greater than approximately 60 centimeters (24 inches). For a vehicle 2.6 meters (102 inches) wide, this corresponds to two 89-centimeter (35-inch) seat banks and two 1.5- to 2-centimeter (4- to 5-inch) walls.

6-1.1.4.1. Floor Height

There are three options for floor height: high, 100% low, and partial low. Floors in high-floor vehicles are typically 61 centimeters (25 inches) to 89 centimeters (35 inches) above the pavement on over-the-road coaches and older buses with the engine under the floor. High-floor vehicles have an advantage in BRT applications in which absolute maximum carrying and/or seated capacity is necessary. However, high-floor vehicles may have inordinately high boarding and alighting times unless they are equipped with a rapidly deployed ramp, bridge, or door flap used in conjunction with high-platform stations (as in high-volume BRT applications in Quito, Curitiba, and Bogotá).

Vehicles that are 100% low floor have the great advantage of low boarding and alighting times and the ability to have a door behind the rear axle. However, 100%-low-floor designs also typically lose between four and eight seats to wheel wells intruding into the vehicles, even when relatively small wheel and tire sizes are used. Another disadvantage of 100%-low-floor designs is that mechanical and electrical equipment and fuel tanks must either be stored inside the vehicle, where they take up space, or be put on the roof, where they are difficult to service. A final disadvantage is the difficulty of packaging conventional mechanical drive trains consisting of an engine, a hydraulic-mechanical transmission, connecting drive shafts, a differential, and an axle. In 100%-low-floor vehicles, this type of drive train can also lose up to four seats or the



(Illustration Credit: North American Bus Industries)

Figure 6-6. Pivot Door.

equivalent standing area merely because of the engine and drive train's intrusion into the vehicle.

One of the reasons that many specialized BRT vehicles have electric drive trains utilizing hub-electric motors and single bogies with special, wide, high-load-limit tires is to avoid the packaging difficulties with internal combustion engines and mechanical transmissions requiring intrusive connecting drive shafts, differentials, and axles.

As noted, low-floor vehicles make passenger boarding and alighting faster and more convenient. The TRB's *Transit Capacity and Quality of Service Manual* (1999) indicates that boarding times on low-floor vehicles are reduced by 20% compared with high-floor vehicles. Corresponding reductions for front- and rear-door alighting were, respectively, 20 and 25%. These time reductions can result in higher ridership and revenue and greater capacity without increasing the number of vehicles or operating and maintenance expenditures. Table 6-2 shows passenger service times with multiple-channel passenger movements.

The passenger service times shown in Table 6-2 are for conventional, steered buses with a gap between the edge of the stop or station platform and the vehicle. There are a variety of specialized BRT vehicles that facilitate no-step, small-gap boarding and alighting. Guidance systems on these vehicles—whether magnetic, optical, or mechanical—allow the vehicle to be precisely “docked” at stations. When these guidance systems are used for docking, the space between vehicle and platform is within the ADA maximum horizontal gap allowed for rail transit vehicles (approximately 3 inches). Stations served by these guided, low-floor vehicles will have slightly raised platforms (about 11 to 14 inches high instead of the roughly 6-inch normal curb height) to permit platform-to-floor, no-step, direct boarding and alighting.

Guided vehicles, used in conjunction with stations having platforms at the same height as the vehicle floor, can be expected to have boarding and alighting times similar to those on heavy rail or on some LRT systems, or approximately 1 second per person less than the passenger service times for conventional buses shown in Table 6-2. Besides reducing average passenger service times, no-step, no-gap boarding and alighting can significantly reduce the time it takes for customers with disabilities or customers with children in strollers or prams to board and alight from BRT vehicles. This, combined with wide aisles, can significantly reduce passenger service times for these customers and thus improve schedule reliability.

As noted above, another way that the advantages of a guided, low-floor vehicle can be obtained without the disadvantages of 100%-low-floor designs is to use a high-floor vehicle with a rapidly deployed ramp, bridge, or door flap in conjunction with high-platform stations. The disadvantage of this approach (usually used with left-hand doors to support center-median platforms) is an inability to service off-line stations that are not configured with high platforms and center platforms. This disadvantage could be overcome by

having doors on both sides of vehicles and steps feeding some of them, but this would reduce seating capacity, and the system would suffer from increased dwell times at the off-line stations.

#### 6-1.1.4.2. *Floor Flatness*

There are two types of low-floor vehicles potentially applicable to BRT: 100%-low-floor and mixed low-floor/high-floor (usually 65 to 70% low-floor) designs. The advantages of 100%-low-floor vehicles are the following:

- No standing capacity is lost to the step up;
- Having no step up lowers the probability of accidental falls;
- Better mobility within the rear portion of vehicles leads to higher utilization of this area, which is especially important with large articulated buses;
- Easier internal passenger circulation, which leads to lower dwell times and better capacity utilization; and
- The ability to put an additional door in the rear of the rear axle, which leads to lower dwell times in certain situations.

The major disadvantage of 100%-low-floor vehicles when compared with partially low-floor vehicles is the loss of space caused by the intrusion of wheel wells and the drive train and the use of internal space for fuel tanks, batteries, and other devices that otherwise would be under the floor. Some of those devices can be placed in the vehicle's “attic” or on the roof; however, this creates access problems and increased maintenance difficulties and costs. Photo 6-I shows an interior view of a 100%-low-floor vehicle. Photo 6-J shows the 12.2-meter (40-foot) partial-low-floor, step-up vehicle used by the Los Angeles Metro Rapid system.



(Photo Credit: Irisbus North America)

*Photo 6-I. Interior view to rear of 100%-low-floor BRT vehicle.*



(Photo Credit: Los Angeles County Transit Authority)

*Photo 6-J. 12.2 meter (40-foot), CNG, North American Bus Industries bus with partial (70%) low floor and step up to rear section—Los Angeles Metro Rapid bus.*

As shown in Photo 6-K, a wide, no-step aisle supports circulation and makes it easier to access the rear of long, articulated vehicles. Photo 6-L illustrates no-step boarding and alighting, as enabled by precision docking through an optical guidance system.

Another class of specialized BRT vehicles has door flap plates or “bridges” that rapidly deploy from the vehicle when it pulls into a high-platform BRT station. The bridges allow no-step, no-gap boarding and alighting, yielding the extremely low passenger service times characteristic of high-platform metro rail and some LRT systems. To date, these vehicles have been used only in South America, on 18-meter single and 24-meter (80-foot) double articulated buses in Curitiba and São Paulo, Brazil, and on 18-meter (60-foot) vehicles in Quito, Ecuador. The vehicles used in Curitiba, as shown in Photo 6-M, use boarding/alighting “bridges” in the lower part of each door opening. The vehicles used in these applications combine the boarding and alighting ease and speed of low-floor, guided vehicles with the interior room and capacity of high-floor vehicles. The downside of this arrangement is that the vehicles can only operate to/from high-platform



(Photo Credit: Translohr, France)

*Photo 6-K. Wide, no-step aisle supports circulation and makes it easier to access rear of long, articulated vehicles.*



(Photo Credit: Sam Zimmerman and Irisbus North America)

*Photo 6-L. No-step boarding and alighting enabled by optical guidance system.*



*Photo 6-M. Bi-articulated Volvo of Brazil (Marco Polo) high-floor BRT vehicle with boarding/alighting “bridges” in lower part of each door opening (Curitiba, Brazil).*

stations that match the vehicles’ high floors unless a combination of doors is provided.

## 6-1.2. Key Physical Features

### 6-1.2.1. BRT Propulsion Systems

BRT vehicle propulsion systems affect system performance, ride quality, environmental impacts (including noise and air pollutant emissions), attractiveness to customers and non-customers, service reliability, overall costs, and financial feasibility. An increasing variety of propulsion systems is in use or under development, particularly for use in BRT vehicles, but there are four basic types of systems. The most prevalent propulsion system is the thermal or internal combustion engine, usually diesel cycle (compression ignition) driving a hydraulic-mechanical transmission. The second commonly used propulsion system is the electric vehicle or trolley bus. Trolley buses normally use electric power collected from an overhead contact system (trolley wires) to power an on-board electric motor or motors. However, a number of other power distribution/collection systems have been developed and tried.

The third type of system has “dual mode” capabilities. These are typified by the 18-meter (60-foot) articulated dual mode vehicles used in Seattle’s CBD bus tunnel and the vehicles that will be used on the South Boston Transitway. These vehicles have full service capabilities when powered either by an independent thermal engine (e.g., diesel, CNG, or gas turbine) or by electric motors that receive their energy from overhead contact wires.

The fourth and arguably most complex type of vehicle propulsion is the hybrid thermal-electric (the thermal part can be diesel, CNG, or gas turbine). By definition, hybrid vehicles have both thermal and electric propulsion capabilities, but they also have on-board energy storage capabilities. The on-board energy storage is usually electric (either a battery or ultra-capacitor), although mechanical systems using flywheels and hydraulic systems with compressed gas tanks have been tried with mixed success in the past.

This on-board energy storage allows the thermal engine to be operated within its maximum fuel efficiency and mini-

mum emissions range and also provides the highly peaked energy and power needed for acceleration away from stops. This reduces the stress on the engine and allows it to be smaller and lighter, significantly reducing air and noise emissions and fuel consumption. The on-board energy storage takes advantage of regenerative braking to reduce fuel consumption and brake wear and tear.

### 6-1.2.2. Internal Combustion Engines

The most common propulsion plant, and the one that would be likely if a conventional bus is selected for a BRT application, is the internal combustion (e.g., clean diesel and CNG spark ignition) engine driving a torque converter connected to an automatic four-, five- or six-speed transmission (gearbox) that is then connected to a driveshaft. Power output is typically in the range of 250 to 350 gross horsepower; however, for articulated vehicles operating on hilly terrain, engines up to 450 gross horsepower have been used.

After deductions for driving auxiliaries such as an alternator and air-conditioning compressor and after friction losses through the drive train, the net horsepower delivered to the wheels can be substantially less than the gross horsepower output. The trend is for vehicles to require more withdrawal of power for the alternator as the quantity of electrical equipment (e.g., electric rather than direct-driven air conditioning) on board increases.

CNG-fuelled internal combustion engines are used by many operators to reduce emissions. CNG engines have significantly higher fuel consumption and costs and generally higher maintenance costs because to date they feature spark ignition and are throttled (as opposed to unthrottled) compression ignition diesels. They also require costly special garaging, servicing, and fuelling facilities.

There have been significant improvements in diesel engines over the last two decades in response to the need to reduce emissions. Electronically controlled, “drive-by-wire” clean diesel engines with exhaust gas recirculation have significantly reduced particulate, hydrocarbon, nitrous oxide (NO<sub>x</sub>) and carbon monoxide emissions from pre-emissions control level by orders of magnitude.

Today’s electronically controlled clean diesel engines—using low-sulphur fuel combined with electronically controlled hydraulic-mechanical transmissions with self-cleaning catalytic converters—can have lower particulate and hydrocarbon emissions than CNG spark ignition engines, although they can have slightly higher NO<sub>x</sub> emissions. These are described in more detail in Section 6-2.

Contemporary spark ignition CNG engines have low particulate emissions and can be somewhat quieter than diesels, but have higher total weight. (High-pressure fuel tanks have relatively high operating and maintenance costs and higher initial capital costs of about \$50,000 per vehicle). They also

have additional fuelling infrastructure costs compared with clean diesel vehicles.

In the future, clean diesel engines using catalytic converters enabled by low-sulphur fuels and either CNG spark ignition or diesel hybrids promise an almost complete elimination of emissions as a planning and project development issue. At the same time, advances in CNG engines (e.g., unthrottled diesel fuel compression ignition of unthrottled gas-air mixtures) will significantly lower CNG operating costs, although additional infrastructure costs will remain.

### 6-1.2.3. All-Electric Trolley Buses

The other common propulsion system that has been proven over many decades of operation is the fully electric trolley bus. It uses an electric power usually provided from overhead contact (trolley) wires to drive motors that can be reversed to brake the vehicle (saving brake wear and tear) and to regenerate power for other vehicles that may be simultaneously accelerating. Unlike rail vehicles that have only one contact wire because the rails provide the ground, trolley buses collect power from two wires, one hot, one ground. Trolley buses sometimes carry on-board energy storage or power production mechanisms, usually batteries or a small “donkey” engine plus generator, to enable them to operate for short distances away from overhead contact wires, in order to get around obstructions or to get to maintenance facilities if there are central power system problems.

Over the years, a number of attempts have been made to distribute/collect electric power for streetcars, light rail vehicles, and trolley buses using different technologies than the visually intrusive overhead contact wires. These nonstandard distribution/collection techniques included underground conduits and contact “third” rails that were contacted by “ploughs” that extended below the streetcar through a narrow continuous slot in the street. Although this approach was aesthetically superior to overhead cables, it was expensive to build and maintain, had safety problems, and created difficulties for other city functions, such as firefighting and utility maintenance.

A new approach for BRT vehicles is called the “stream system,” developed in Italy. It consists of underground conduits with insulated contact plates on top at the street surface. These plates are safely energized only when the contact shoe mounted under a BRT vehicle is directly overhead. This energization occurs when a powerful on-board magnet lifts up a continuous flexible power cable in a prefabricated, waterproof, and insulated box structure placed in a trench. This, in turn, energizes the contact plate at the street surface from underneath. Although this technology is not yet proven in extended revenue service, it has been successfully tested in Trieste, Italy. To date, speeds are limited to under about 33 kilometers (20 miles) per hour.

The strongest advantages of an all-electric vehicle using an external power source for BRT applications are environ-

mental friendliness in terms of both noise and air (at least in the vicinity of the line) emissions and very high power and torque output, leading to high acceleration rates. Modern electric vehicles also feature much smoother acceleration and deceleration than conventional internal combustion vehicles with multi-shift point hydraulic-mechanical transmissions.

Trolley buses generally also have the highest power-to-weight ratio of any transit vehicle, power that can be effectively transmitted to the pavement through high-traction rubber tires. Photo 6-N shows the Quito, Ecuador, Trolebus, which is an all-electric BRT vehicle. A vehicle with electric propulsion will always have the potential for higher starting torque and higher horsepower at any given revolutions per minute (RPMs) than a thermal engine of equivalent physical size and weight. An electric vehicle has excellent acceleration and hill climb ability because the maximum tractive effort (the force applied at the wheel) of a direct current motor occurs at 0 RPMs.

By contrast, a diesel engine must spin to about 2,000 RPMs to produce maximum torque, and a clutch must be used to allow the engine to be engaged with the wheels at a standing start, at considerably lower RPMs and less starting torque. Another advantage of electric traction is being able to power more than one set of wheels, which provides better traction in slippery conditions.

As a practical matter, the greater torque at lower RPMs that is available with electric motors compared with thermal engines is a benefit with limited application. Normal acceleration rates generally will not exceed approximately 1.3 meters per second per second if the vehicle is to have standing passengers. Otherwise, there will be excessive grip strength required of passengers, and they will be uncomfortable. Emergency braking rates as high as 5 meters per second per



(Photo Credit: John Cracknell)

Photo 6-N. Trolebus, an all-electric BRT vehicle (Quito, Ecuador).

second can be obtained with any type of vehicle, regardless of motive power.

Electric traction allows high acceleration from a standing start, which is useful when there is frequent starting and stopping. However, this advantage fades as starting and stopping are less frequent and high speed is desired. When higher RPMs are maintained, either electric propulsion or internal combustion propulsion can achieve practical, maximum acceleration rates. A final advantage of electric vehicles is that because of their lower vibration, all systems (including the electric motors, the air conditioning system, all electronics, and the body) tend to have a longer service life than their thermal equivalents.

The disadvantages of trolley buses are the expense of building and maintaining them, visually intrusive infrastructure, and service inflexibility (made necessary by the need to access power provided via costly and thus limited-extent fixed infrastructure such as overhead contact wires). This inflexibility can be overcome in two ways.

One way to overcome the service inflexibility of trolley buses is to use an all-electric vehicle for the all-stop service and LRT-like service in places where acceleration rate and environmental friendliness (especially low noise) are most important. Express or skip-stop services would be provided by vehicles with thermal engines that do not require access to overhead contact wires or another external energy source. The other way to overcome the service inflexibility of trolley buses is to utilize “dual mode” vehicles that have full service capabilities both on and off wire.

#### 6-1.2.4. *Dual Mode (Dual Power) Thermal-Electric Drives*

Dual mode vehicles combine an electric trolley bus with an internal combustion engine (e.g., diesel, CNG, or gas turbine) capable of providing full, stand-alone performance. Dual mode vehicles therefore have the advantages of both trolleys and normal buses with internal combustion engines. Electricity is obtained from overhead contact wires for part of a given route’s trajectory, typically in the center of the city. The vehicles used in the Seattle CBD bus tunnel have this capacity.

There can be two configurations for dual mode articulated vehicles. In the first, one axle is driven by the electric motor, the other by the internal combustion engine/transmission (as in Seattle). This is the most straightforward configuration, but it has drawbacks. It must carry two complete propulsion plants, making for a heavy vehicle. It also precludes the possibility of powering more than one axle simultaneously.

The second dual mode configuration uses an internal combustion engine and a generator/alternator (in lieu of overhead contact wires) to provide electric power to the motor or motors that actually turn the wheels, thus avoiding

the need for both an electric motor and a mechanical transmission. This type of vehicle can also operate as either a trolley bus or a diesel-electric vehicle. With this approach, the ride quality of the vehicle is significantly advanced because the all-electric drive eliminates the often harsh shift points associated with hydraulic-mechanical transmissions, but this type of vehicle tends to have lower fuel economy than other configurations.

Having internally generated or externally provided (via trolley wires) electricity allows powering of multiple wheels in the same way as a light rail vehicle, an approach used for vehicles in Las Vegas; Nancy, France; and Boston (as shown in Photo 6-O) and currently in service in Lausanne, Switzerland. Drive motors can also be mounted on a single axle to power the axle’s two wheel sets, the typical solution for trolley buses, or there can be no axles at all, only motors directly within the hub of the wheel. When the motors are in the wheel, tires and wheels must be of a wide design.

Putting the motors in the wheel hub is the approach taken in all of the specialized BRT vehicles and accounts for a significant portion of their much higher cost. The use of hub motors means that the floor can be very low in the center of the vehicle, making for a very wide aisle, a 100% low floor, and the ability to have a door to the rear of the rear axle. One disadvantage is that these motors are very expensive, and the resulting system is heavy. Photo 6-P shows the drive axles with hub motors used on a BRT vehicle.

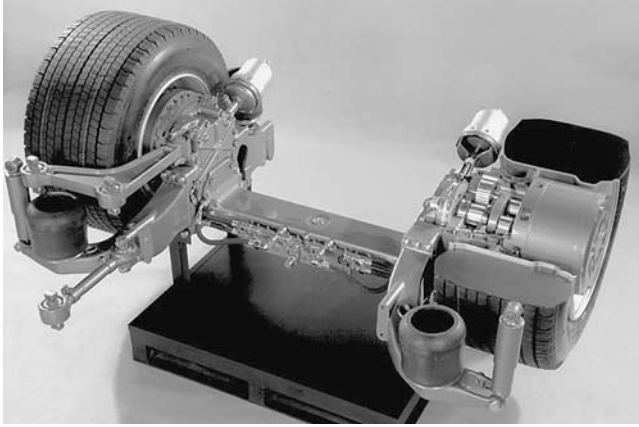
Dual mode vehicles are attractive for transit operations because they can combine the performance and other environmental advantages of a trolley bus when they are needed with the freedom of movement of a conventional bus using an on-board prime mover. The main disadvantages of dual mode vehicles are their weight and cost. The Neoplan vehicles that will be used on the South Boston Transitway have an estimated cost of well over \$1 million each, compared with about \$500,000 for a standard, diesel, 70%-low-floor, articulated



(Photo Credit: MBTA)

*Photo 6-O. Neoplan AN 460 LF18-meter (60-foot) dual mode, diesel-electric BRT vehicle proposed for South Boston Transitway.*





(Photo Credit: Irisbus North America)

*Photo 6-P. Drive axle with hub motor that permits a wide aisle and 100% low floor.*

bus. Dual mode vehicles are also more complex than conventional buses. Whereas a conventional bus requires maintenance of a single thermal engine and a tried and true hydraulic-mechanical transmission, dual mode vehicles require more maintenance effort and cost because they have more components. The trade-offs that must be considered in specifying the type of dual mode vehicle to use for a particular BRT operation involve cost, complexity/reliability/maintainability, weight, fuel consumption, and acceleration.

#### *6-1.2.5. Hybrid Electric Drives with Energy Storage*

Hybrid drives combine a dual power vehicle (e.g., diesel, CNG spark ignition, or gas turbine driving a generator/alternator) with an on-board energy storage medium such as a battery pack or an ultra-capacitor. True hybrid drive BRT vehicles perform even better than vehicles with a simple thermal-electric drive (in which the thermal power is provided by diesel, liquid petroleum gas [LPG], or CNG) without energy storage. Photo 6-Q shows a hybrid drive BRT vehicle.

A hybrid vehicle with energy storage allows an engine with less horsepower to be used because the engine can be run at a much more constant load. When high power is needed, the additional power is drawn from storage. Conversely, the engine can recharge the energy storage medium while cruising or coasting. Regeneration during braking also recharges the storage medium and reduces brake wear and tear.

There are noise and air pollution advantages to hybrid drive vehicles. Peak noise levels are reduced since high engine RPMs are not required to achieve adequate acceleration or to climb hills. The air pollution (and fuel consumption) advantages stem from the more constant load on the engine. It is much easier to optimally tune an engine to reduce emissions



(Photo Credit: Berkhof Jonckheere)

*Photo 6-Q. Hybrid BRT vehicle.*

and fuel consumption within a narrow range of operations than in a wide range of applications. This is one of the special benefits of hybrid propulsion systems, even when diesel engines are part of the mix.

Hybrid vehicles can use either of the two propulsion system configurations noted above under dual mode vehicles, but they may not need trolley wires. The third type of dual power configuration available for hybrids involves a thermal engine, a motor/generator, and a mechanical transmission, all mounted on one drive shaft. This approach, similar to the approach used by the Honda Insight and hybrid Honda Civic automobiles, is being tested in revenue service in Seattle as a replacement for its Breda dual mode vehicles. This third type of dual power configuration has the weight penalty of a transmission motor/generator or alternator and the stepped shifting of a hydraulic-mechanical transmission; however, it tends to have better fuel efficiency and acceleration than alternative configurations.

#### *6-1.2.6. Fuel Cells*

Fuel cells, which are now in demonstration operation throughout the world, will mark a clear breakthrough in technology for buses when commercialized, especially for BRT vehicles. Fuel cells utilize hydrogen and oxygen to directly produce electricity in the presence of a catalyst, without engines and generators/alternators of any kind. There are two basic fuel cell approaches for vehicles, one involving the use of hydrogen gas carried in high-pressure cylinders (up to 350 bar pressure), and another in which the hydrogen is chemically separated from a liquid hydrocarbon fuel, such as methanol, in a reformer onboard the bus.

Water vapor is the only exhaust product from a vehicle using pure hydrogen as a fuel, an improvement over the imperfectly combusted hydrocarbons, nitrous oxides, carbon monoxide and carbon dioxide that make up the potent greenhouse gas

mix emitted by internal combustion engines. Fuel cell technology promises to be an environmental boon for the transit industry as well as the entire large-vehicle industry because it can run on hydrogen created from a variety of renewable sources. Other than fan noise, fuel cell buses are remarkably quiet, quieter than most cars.

Obstacles still to be overcome with fuel cell vehicles include the following:

- The need for hydrogen extraction (which can be an expensive, environmentally dirty operation if done centrally);
- The need for more efficient, less expensive, lighter, and more durable reformers if on-board liquid hydrocarbon fuels (e.g., methanol) are to be used;
- The need for a new hydrogen or methanol supply infrastructure throughout North America;
- The need for enough on-board fuel storage capacity to provide adequate operating range regardless of fuel; and
- The need to reduce the initial capital and ongoing operating and maintenance costs of all the above.

This technology is still some years away from commercialization and competitive purchase price, but the specialized vehicles have been designed for eventual conversion to fuel cell technology.

## 6-2. EMISSIONS

Given the service levels entailed in BRT applications (200 or more vehicles passing by a single point in a single peak hour), air and noise emissions are critical vehicle planning and design parameters. Both are frequently cited as reasons that BRT systems are often passed over in favor of LRT, and they are thus important vehicle planning and selection criteria.

### 6-2.1. Air Emissions

Great progress has been made in reducing air pollution emissions from rubber-tired transit vehicles. The base diesel is significantly improved from previous generations of mechanically governed diesel engines. According to *A Study of Bus Propulsion Technologies Applicable in Connecticut* (Werle, 2001), contemporary four-cycle, electronically controlled diesel engines have less than one-third (as low as 15% of earlier two cycle engines) of the particulate emissions of pre-1994 engines and significantly lower NO<sub>x</sub>, carbon monoxide, and hydrocarbon emissions.

Figures 6-7 through 6-10 illustrate that the propulsion technologies increasingly being found on specialized BRT vehicles and high-end conventional buses (e.g., CNG and clean diesel hybrids) have lowered emissions for all pollutant types dramatically over the last 10 years. Diesel hybrids

using low-sulphur fuels and continuously regenerating technologies (i.e., catalytic converters) reduce particulate emissions to virtually undetectable levels and hydrocarbon ozone precursors by 70%; they also provide significant improvement in fuel economy, upwards of a 30% increase.

Clean diesels using low-sulphur fuel and catalytic converters are not expected to cost significantly more to purchase when they go into more widespread use. They will likely only cost a few cents more per mile to operate (slightly higher fuel costs) than current conventional diesel engines and have similar reliability levels. The low-sulphur diesel fuel needed for the cleanest clean diesel buses—those with after-burning, self-cleaning catalytic converters—is currently available only in some U.S. locations today, but the U.S. EPA has mandated that it be available everywhere by January 2006.

Diesel hybrids currently have somewhat lower levels of reliability than conventional hybrids and initial purchase prices of at least \$150,000. As more and more of these vehicles go into general use, reliability can be expected to improve to straight diesel levels, and the initial purchase price can be expected to be reduced to that of CNG vehicles, about \$50,000.

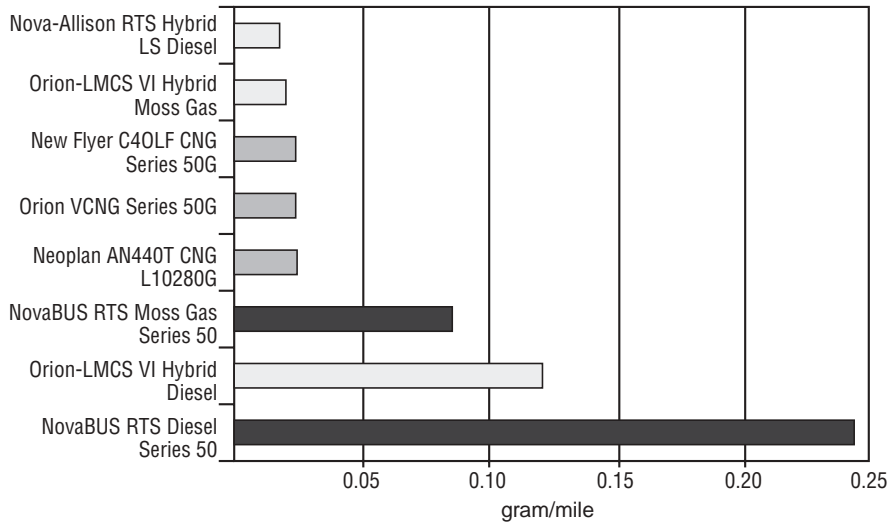
### 6-2.2. Noise

A study done in late 1970s by Saab-Scania on bus noise determined that most bus noise was due to peculiarities associated with diesel engines that could be easily overcome. The major sources of bus noise were the following:

- Mechanical noise (e.g., high compression ratios causing pistons to move around in their respective cylinders, known as “piston slap”);
- Diesel knock from high-pressure fuel injection;
- Fan noise;
- Air intake noise;
- Exhaust noise (limited issue); and
- Tire noise.

Saab was able to reduce bus noise to levels that were the same or less than those of contemporary cars (78 decibels under full acceleration 10 meters from the vehicle on the curb-side). They were able to achieve this with several relatively minor changes such as using a larger, slower-turning fan pointing backward into the vehicle’s back-wash; using a larger intake muffler; using electronically controlled “multi-squirt” fuel injection; and encapsulating the engine with sound insulation, particularly underneath, to reduce mechanical noise bouncing off the pavement. An independent FTA vehicle research project came to the same conclusion and designed a noise reduction kit that cost only about \$10,000 to reduce noise by 5 to 10 decibels.

This was the situation over 20 years ago for previous-generation propulsion technology buses. Today’s BRT vehicles with four-cycle, clean diesels; low-compression CNG



(Chart Courtesy of Northeast Advanced Vehicle Coalition)

Figure 6-7. Particulate emissions for various propulsion system types.

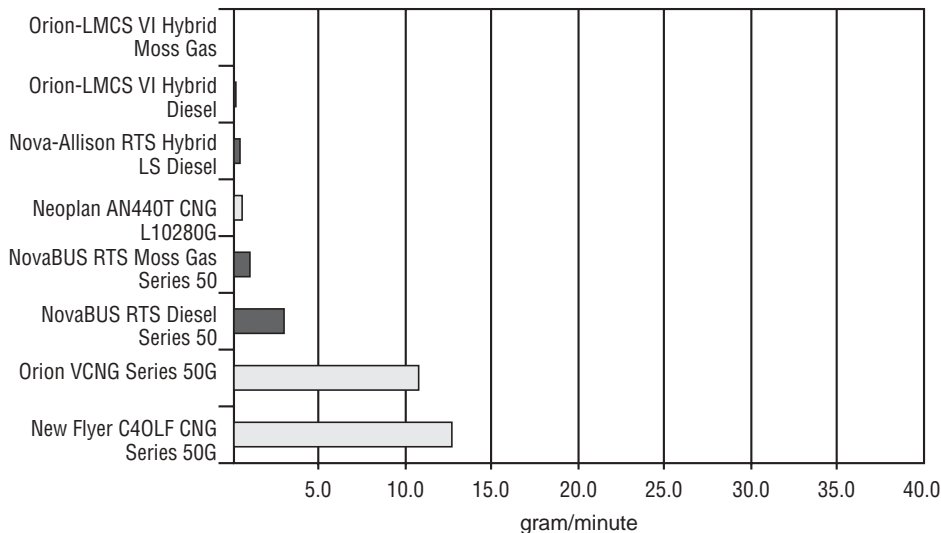
spark ignition engines; and/or gas turbines (either alone or combined with electric motors or hybrid drives with energy storage load levelling) should make noise control even easier because the basic engine noise emissions are even lower to start with. The major conclusion here is that noise emissions can be reduced to levels that are, for all practical purposes, insignificant in most BRT applications, and planners and implementers should elect to put a noise emissions specification in their plans and procurement documents.

### 6-3. GUIDANCE SYSTEMS

One important new development in rubber-tired transit vehicles, particularly those used for rapid transit, is the use of

advanced ITS technologies to provide lateral and even longitudinal vehicle guidance. These systems, as distinct from the mechanical bus guidance technologies of the past (e.g., O’Bahn), eliminate the need for expensive physical infrastructure because the guidance system is based on the electronic detection of either magnetic or painted markers. The implications of such systems on right-of-way requirements, customer comfort, speeds, dwell times, and reliability can be profound.

Rubber-tired, steered BRT vehicles can operate in any running way environment, from running ways where they are mixed in with general traffic, to completely grade-separated, specialized busways like metro rail lines. This significant flexibility advantage allows a minimum of specialized guideway to be built without forcing an undue amount of transfer-



(Chart Courtesy of Northeast Advanced Vehicle Coalition)

Figure 6-8. Carbon monoxide emissions for various propulsion system types.

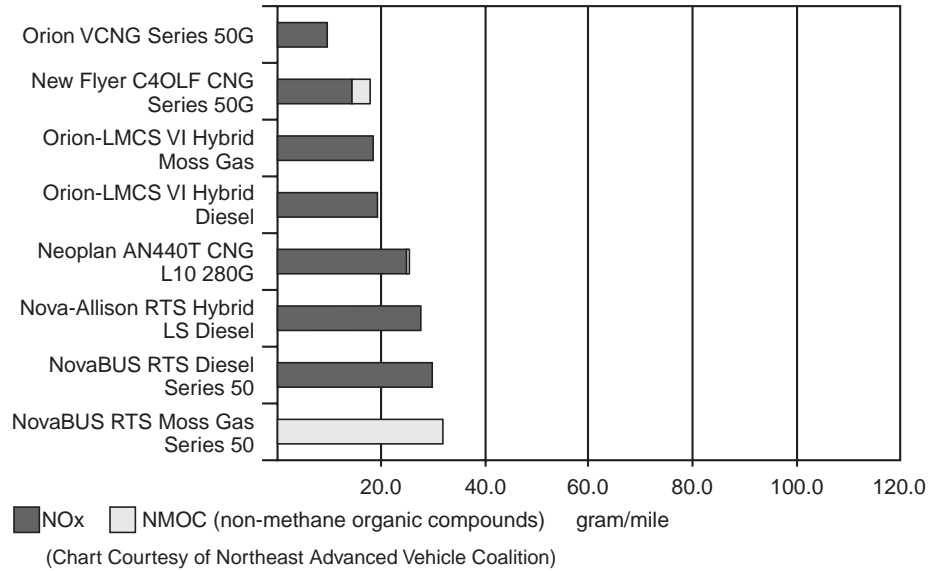


Figure 6-9. Ozone precursor emissions (hydrocarbons, NO<sub>x</sub>) for various propulsion system types.

ring; however, this feature presents some disadvantages as well. These include the potential for passenger discomfort, the need for extra right-of-way with driven vehicles, and the difficulty drivers have in getting close enough to a station platform to permit no-step boarding and alighting.

Perhaps the most significant disadvantage is the inability of conventional, steered-only vehicles (buses) to support rapid, no-step, station-platform-to-vehicle-floor boarding and alighting at low-platform stations that are easy and inexpensive to construct. The *Transit Capacity and Quality of Service Manual* (Kittelson and Associates, Inc., 1999) shows no-

step, no-fare-payment-per-passenger service times from 1.1 to 2.6 seconds for mostly boarding situations, 1.4 to 2.0 seconds for mostly alighting situations, and 2 to 3 seconds for mixed boarding and alighting situations.

Although part of the difference between these numbers and those shown in Table 6-2 is due to door width and internal vehicle configuration, a high proportion is due to the fact that people have to step up/down to board or alight from most buses. In fact, the high-floor LRT vehicles shown in the *Transit Capacity and Quality of Service Manual* (Kittelson and Associates, Inc., 1999) have significantly higher boarding and

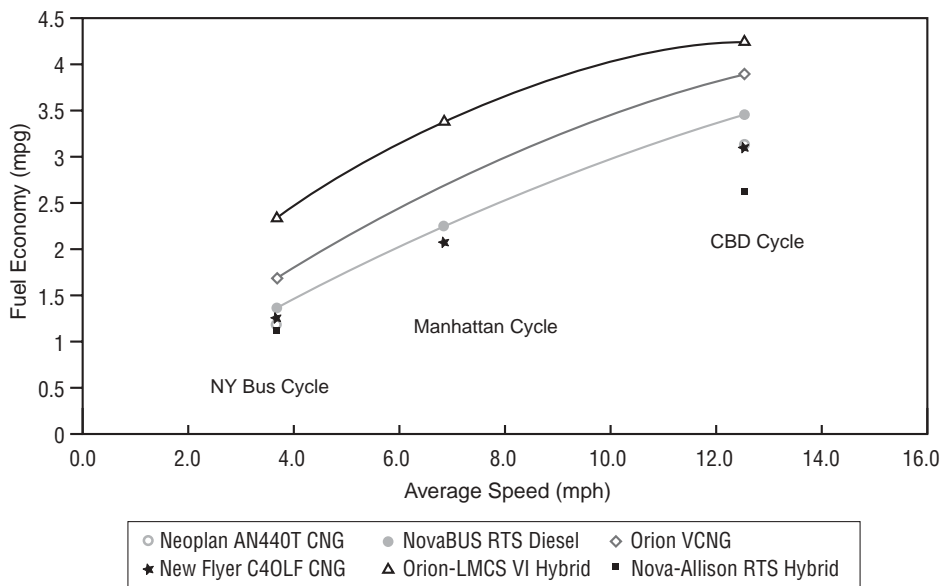


Figure 6-10. Fuel economy for various propulsion system types.

alighting times (up to 3.4 seconds per passenger) compared with no-step heavy rail systems (as low as 2.0 seconds).

In response to these disadvantages, a number of technologies have emerged in recent years that impart to BRT vehicles the kind of tracking precision normally associated with rail-based rapid-transit modes. Even low-floor buses may require stepping up and down if a vehicle is stopped far enough from the curb to require a step off the curb to the pavement level and then a step up into the vehicle. Therefore, one important new development in rubber-tired transit vehicles, particularly those used for rapid transit, is the use of advanced ITS technologies to provide lateral vehicle guidance and thus support “precision docking” as well as provide longitudinal control (e.g., starting and stopping and maintaining a safe distance from vehicles ahead). These systems can provide the more comfortable tracking and minimum right-of-way requirements of rail vehicles, but perhaps even more importantly, they allow no-step boarding and alighting, which reduces dwell time.

### 6-3.1. Mechanical Guidance

The first recent mechanical guidance system for buses was originally developed as the “O-Bahn” system. This guidance approach, similar to that utilized on the rubber-tired, automated people mover systems often found at airports, has been proven in service for many years in Essen, Germany, and Adelaide, Australia, with newer, similar non-O-Bahn applications in a number of British cities (e.g., Leeds).

These systems can utilize a pre-cast, concrete “track” with low vertical side rails or curbs that are contacted by laterally mounted guide wheels that, in turn, are connected to the vehicle steering system’s idler arm. The guideway tapers where the vehicle enters the guided section to allow easy entrance. Once on the guideway, the operator does not steer, but applies only power and braking. After leaving the guideway, driver steering is reactivated. In Essen, the vehicles shared a tunnel with light rail vehicles. Both Essen and Adelaide applications operated successfully for years (Essen has now ceased operation) with enviable safety records, few safety problems, and excellent customer satisfaction.

A more recent lateral mechanical guidance technique is to use one central guide rail or central metal guide groove in the roadway. In the guide rail approach, the rail is contacted by a guide wheel, or sheave. There is one sheave mounted between each set of wheels. In the guide groove approach, the guide is contacted by a wheeled arm mounted on the center-line of the bus. In either case, the contacting mechanism can be retracted when the bus is not operated on a guided section.

There are some differences in how this guidance approach has been utilized in specialized BRT vehicles. For example, on several vehicles, all axles swivel to provide all-wheel steering to simplify precision docking and reduce the turning radius. Another vehicle has rigid axles directly under the

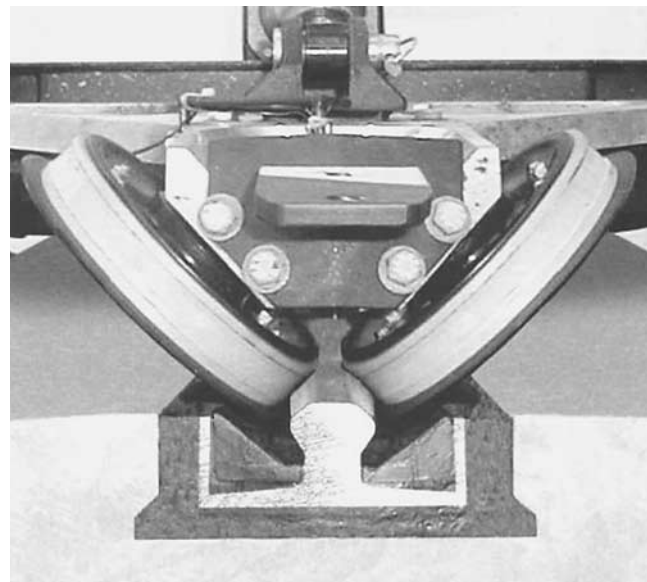
articulation joint, also permitting all wheels to swivel and follow the same track. Tracked systems can require complex locking/unlocking mechanisms to enable and disable axle movement relative to the vehicle chassis depending on whether the vehicle is traveling along a guideway. Both types of vehicles were tested extensively in revenue service on the Trans Val de Marne site in suburban Paris (Ventejol, 2001).

The advantages of mechanical guidance systems are their tight running trajectory; precision docking; and high degree of safety, simplicity, and robustness under severe operating conditions. Disadvantages include vehicle weight and the additional infrastructure necessary for them to work (e.g., the vertical guiding surfaces or the track embedded in the pavement). It also may be difficult for vehicles to leave and enter guided track sections, precluding complex routing patterns.

Guided vehicles often need a right-of-way that is physically separate from other traffic because with some systems (e.g., O-Bahn) other vehicles cannot cross the right-of-way except at predetermined locations. Photo 6-R shows the guidance mechanism on the Translohr BRT vehicle. Photo 6-S illustrates a running way with guidance track used by mechanically guided vehicles in Nancy, France. Photo 6-T shows a running way used by the mechanically guided O-Bahn system in Adelaide, Australia. This photo illustrates the use of vertical curbs against which the guidance wheels play.

### 6-3.2. Optical Guidance

Another lateral guidance technique uses a video camera mounted on the dashboard of the vehicle for position data acquisition. It views the position of two parallel stripes



(Photo Credit: Translohr, France)

*Photo 6-R. Guidance mechanism on BRT vehicle and trackway.*



(Photo Credit: Bombardier)

*Photo 6-S. Running way incorporating guidance track used by Bombardier GLT vehicles (Nancy, France).*

painted on the roadway in relation to the lateral position of the vehicle and translates the relative position data to a computer that actually steers the vehicle with a servo motor when the system is activated.

The video systems work even if the painted guide lines are partially obscured by another vehicle, leaves, or snow.



*Photo 6-T. Running way with vertical guidance walls used by mechanically guided O-Bahn system (Adelaide, Australia).*

The system facilitates very tight trajectories (approximately 5 centimeters), allowing close passing in the opposite direction and error-free steering along narrow streets. It also allows vehicles to stop at stations within tight lateral tolerances. This allows high-speed vehicle entry into and exit out of stations without tire scrubbing and obviates the need for time-consuming ramp and/or lift deployment for access/egress by passengers who have disabilities. This latter feature can result in significant savings in station service/dwell times over steering-only vehicles.

Optical guidance systems avoid the vehicle weight associated with mechanical systems, and infrastructure costs are modest because no physical guide is installed in the road beyond painted stripes. With optical guidance systems, the operator can take over at any time. Further, these systems are compatible with operating plans that feature mixed local and express operations on a single guideway because of their ease of driver-steered vehicle entry and exit.

Optical guidance systems are used on some specialized BRT vehicles. As shown in Photo 6-U, the video camera on the dashboard and the painted dashed lines on the pavement are key components of the optical guidance system. Photo 6-V illustrates the BRT running way in Rouen, France, which has dashed lines for the optical guidance system. This system been thoroughly tested in service on the Trans Val de Marne in Paris and has been used in Rouen and Clermont Ferrand, France, since 2001. Las Vegas's BRT system, which will utilize the Irisbus Cividis vehicles, is scheduled to go into operation in the fall of 2003.

One disadvantage of the optical guidance system used on the Irisbus Cividis system is that because it turns like a conventional articulated bus with only one guided/steered axle, it must have a wider turning area than a vehicle on



(Photo Credit: Irisbus North America)

*Photo 6-U. BRT vehicle with a video camera on the vehicle dashboard and painted, dashed lines on the pavement as key components of the optical guidance system.*



(Photo Credit: Sam Zimmerman)

*Photo 6-V. BRT running way with dashed lines for optical guidance system (Rouen, France).*

which all wheels follow the same track. This is the case with most tracked BRT vehicle systems. Optical guidance also lacks the safety of positive physical guidance. At high speeds, it is recommended that security curbs about 20 centimeters (8 inches) high be used that backup guide wheels can follow in case of system failure. There also may be issues at intersections where a dedicated transitway's guidance lines may cross other traffic markings and confuse the system. Other safety issues include snow obscuring the guidance lines and vandals painting errant ones.

### 6-3.3. Magnetic and Other Electronic Guidance Systems

Several organizations have developed magnetic guidance systems for BRT. These systems use data about a vehicle's position relative to a magnetic field created by magnets or wires with electric current running through them embedded in the pavement's surface for guidance.

The advantage of these systems is their lower cost and vehicle weight in comparison with mechanical systems and the fact that data can be acquired from the magnetic field with regard to snow cover or other pavement surface conditions. However, these systems cost more to install and maintain than optical systems.

All guidance systems utilized for BRT, to date, provide lateral guidance that can always be overridden by the driver. A driver must be present on every vehicle to start, accelerate, and stop it. Systems that provide longitudinal control (e.g., starting from and stopping at stations) are under development and in experimental use in Eindhoven, Netherlands. Adaptive cruise control systems that automatically apply the brakes and release the accelerator if an obstruction (a stopped vehicle) is

detected in front of the vehicle are already in use in trucks and will be adapted for BRT vehicle use.

## 6-4. IMAGE

It is not only operating characteristics that define a BRT system. The matched characteristics of the vehicle and physical infrastructure also project a physical image. This image is further enhanced by any particular features and amenities unique to the service, such as precision docking and real-time information at stations. As described more fully in Chapter 8, the image of a BRT system should be carefully cultivated in the initial conceptual planning and design stages. This image may be necessary to the ultimate success of the system for a variety of reasons. One is to attract choice riders by providing them with a transit choice that they perceive as more closely resembling the "quality experience" of driving than the background local bus system. The other reason for cultivating a distinct image and identity is to use the system itself for advertising and conveying information about routing and schedules. Seeing distinct vehicles on certain routes serving certain stops and stations conveys information about where and when the system goes.

It is not always necessary to have a rail-like appearance to be successful, as some successful applications have shown. The MBTA's Silver Line in Boston, Los Angeles's Metro Rapid bus, and Brisbane's highly successful South East Busway all successfully use late-model conventional articulated and single-unit buses that are attractive but do not look like railcars. These systems use a distinct livery to define the respective systems' image and identity. Such a "branded" appearance can distinguish a bus in BRT operation from a regular one. The livery can be different from other buses, but match the livery at BRT stops, stations, and terminals, as well as on information signs, graphics, and all printed matter.

In this way, the branded appearance of BRT vehicles stresses the systemic nature of BRT services. Photo 6-W shows the 12.2-meter (40-foot) bus used on Brisbane's South East Busway.

As of 2003, at least five European bus manufacturers (Irisbus Cavis, Bombardier, Neoplan, APTS, and Translohr) have designed and built specialized BRT vehicles that are similar to light rail vehicles in appearance, interior, and other features (such as guidance). In Europe and South America, Volvo has BRT vehicle projects under way, while in North America, both New Flyer and North American Bus Industries have BRT vehicle projects close to the production of prototypes.

Examples of the features of BRT vehicles include their large sizes and distinct shapes (lengths from 13.75 to 25 meters [45 to 80 feet]); large, panoramic passenger windows; dramatically curved front windscreens; several multiple-steam doors; lateral guidance/precision docking; quiet, thermal-electric hybrid propulsion; and the option for the driver position to be in the center of the vehicle. By comparison, the



(Photo Credit: Barry Gyte, Brisbane, Australia)

*Photo 6-W. Saab Omni “City Bus” on Brisbane’s South East Busway.*

South American specialized vehicles resemble conventional buses much more in appearance, although there are significant functional differences (e.g., vehicle floor-to-station-platform bridges rapidly deployed at stops). In South America, the emphasis is more on acquisition cost and functionality than on image.

Examples of BRT vehicles with distinct, modern images are shown in Photos 6-X through 6-Z. Photo 6-X shows an 18-meter (60-foot) dual mode track-guided modular BRT vehicle. Photo 6-Y shows a 24-meter (80-foot) hybrid, which is a magnetically guided, modular BRT vehicle. Photo 6-Z shows a 13.8-meter (45-foot) composite BRT vehicle.

The interior appearance of a vehicle should also be stylish, in keeping with the exterior appearance. Panoramic and curving windows make the task of designing well-lit and attractive interiors easier. Comfortable, upholstered seats with a generous pitch also contribute to a positive image. However, functionality cannot take second place to appearance, even if specialized vehicles are selected.



(Photo Credit: Translohr, France)

*Photo 6-X. 18-meter (60-foot), dual mode, track-guided, modular BRT vehicle.*



(Photo Credit: Berkhof Jonckheere)

*Photo 6-Y. 24-meter (80-foot) hybrid, magnetically guided, modular BRT vehicle.*

Easy and rapid passenger boarding, alighting, and circulation are still basic BRT vehicle requirements to minimize dwell times. Distinct BRT vehicle interior layouts usually involve large standing/circulation areas around doors. These aid boarding, alighting, and circulation and also function as storage areas for baby carriages, strollers, shopping carts, and wheelchairs and, in the process, support the image of a quality system that meets the needs of the entire community. Photo 6-AA and Photo 6-AB show the interiors of two BRT vehicles.

All transit buses in the United States are being delivered with features to comply with the letter and spirit of the ADA. Thus, as with all buses, they will be equipped with automatic signage and audio announcement systems for announcing stops. Because vehicles specially designed for BRT service operations will support easy and rapid boarding and alighting to accommodate significant passenger flows, they are inherently more accessible for passengers who have disabilities.

Given the special status of BRT vehicles operating in high-profile trunk lines, they are also likely to have a large number of connecting routes and/or branches off the trunk route. Thus, by maintaining a high-profile image, they are likely to provide additional information to the public on board. This can include visual and audio announcement of real-time information about the next stop or stops and the availability of connecting routes.



(Photo Credit: North American Bus Industries)

*Photo 6-Z. 13.8-meter (45-foot) composite BRT vehicle.*





(Photo Credit: Translohr, France)

Photo 6-AA. Translohr BRT vehicle interior.

## 6-5. PROCUREMENT ISSUES AND COSTS

Buses made in the United States that might be suitable for BRT service will generally be articulated, low-floor buses. However, single-unit 12.2-meter (40-foot) vehicles are also being used, such as those used to begin service on the Metro Rapid system in Los Angeles and the Silver Line in Boston. Irrespective of size, the vehicles to be used in BRT service will most likely be similar to those currently in production. Thus, current prices might be a good guideline.

When conducting an actual procurement, more detailed specifications might result in having slightly higher prices. For example, BRT operations might dictate the highest horsepower engine and gearing for acceleration, or three or four sets of double-channel doors might be required. As yet another



(Photo Courtesy of Bombardier)

Photo 6-AB. "Tram on tires" interior.

example, the plush interior with the largest seats available might be required.

Because specialized BRT vehicles are currently produced only in Europe and South America, they do not comply with Buy America requirements for 60% U.S.-produced content. However, at least one transit agency, Citizens Area Transit in Las Vegas, Nevada, has obtained a waiver for the purpose of providing a demonstration site. Order quantities influence the price and willingness to locate manufacturing. As the volume of purchases increases, it may well become practical for vendors to meet Buy America requirements.

There are differences in philosophy between European and U.S. procurement practices that also lead to large differences in purchase prices. These differences must be taken into account when comparing prices between European vehicles intended for Europe and European vehicles intended for export to the United States. European manufacturers tend to sell more standardized models (excluding the specialized vehicles). The buses are specified by selecting amongst some standardized modules. Differences among operators' purchases are confined to a few choices in power output and transmissions, air-conditioning output, minor interior details, and other limited changes. By comparison, U.S. procurements tend to vary a great deal from one agency to the next, including engines from more than one manufacturer, different axles, different door layouts, and different destination signs and other electronics.

Variety in procurement raises cost because of the requirement of procuring supplies in small quantities and preparing different production runs. Table 6-3 shows typical purchase prices for BRT vehicles. U.S. procurements, per FTA mandate, often include 12-year warranties on bodies and chassis and other shorter or longer warranties on drive train components. Warranty costs are almost always considered operating costs in European practice, but in the United States, up to a point, these costs may be capitalized.

Life-cycle costs should also be a prime selection factor in any vehicle procurement, and life-cycle costs are profoundly affected by design life and projected duty cycle. For example, stainless steel vehicle bodies are typically designed for a life of 20 years, whereas conventional mild steel-framed transit buses have a 12-year warranted life. Electric propulsion systems should last longer than mechanical ones, often as long as 30 years. Vehicles in BRT service on dedicated rights-of-way should last longer than vehicles carrying the same number of customers in stop and go traffic with much more frequent local stops.

A careful comparison would dictate reviewing the difference in warranty terms and subtracting the warranty costs from U.S. prices. A rule of thumb is to allow \$50,000 extra for CNG propulsion, whereas a premium of at least \$200,000 appears to be the minimum add-on for hybrid vehicles once they are in general production.

One of FTA's procurement issues relating to specialized BRT vehicles is whether they should be treated as buses, with Altoona testing requirements and mandated 12-year life, or rail

**TABLE 6-3 Typical purchase prices for BRT vehicles in 2002 U.S. dollars**

Vehicle Type / Feature	Cost
60-foot Conventional Diesel Low-Floor Articulated Bus	\$500,000–600,000
60-foot Articulated Trolley Bus	\$900,000–950,000
60-foot (18-meter) BRT Vehicle with guidance, internal combustion—electric or hybrid drive	\$1,000,000–1,600,000
40-foot Conventional Low-Floor Bus	\$300,000–350,000
Hybrid Premium	\$100,000–200,000
CNG Premium (Vehicle Only)	\$50,000–100,000
Electronic (Optical, Magnetic) Guidance	\$100,000

vehicles with a different warranted life. As of this writing, this issue has not yet been fully resolved, but a change in overall investment policy to treat all BRT expenditures the same as expenditures for rail-based modes (as capacity and ridership-attracting enhancements eligible for “New Start” assistance) should go far in clearing up these differences. Issues related to federal funding are addressed more fully in Chapter 9.

#### 6-6. CHAPTER 6 REFERENCES

- Fruin, J. J. *Pedestrian Planning and Design*. Elevator World, Mobile, AL (1987).
- Kittelson and Associates, Inc., Texas Transportation Institute, and Transport Consulting Limited. *TCRP Web Document 6: Transit Capacity and Quality of Service Manual*. Transportation Research Board, National Research Council, Washington, DC (January 1999).
- Kittelson and Associates, Inc. “Update of the First Edition, *Transit Capacity and Quality of Service Manual*” (TCRP Project A-15A). Unpublished Draft (October 2002).
- Ventejol, P. “Trams and Rubber-Tyred Guided Vehicles,” *Savior Faire*, 37 (April 2001) pp. 14–19.
- Werle, M. J. *A Study of Bus Propulsion Technologies Applicable in Connecticut*. Connecticut Academy of Science and Engineering, Hartford, CT (2001).

## CHAPTER 7

# ITS APPLICATIONS

BRT service should be fast, reliable, and safe. Buses should run on time; their performance should be monitored, and schedule adjustments should be done quickly. Passengers should be informed of when buses arrive at stations, and boardings at stations should be fast and convenient. ITSs can achieve these objectives and greatly enhance BRT operations. ITS applications are essential complements to running ways, stations, vehicles, and overall bus operations. They can determine whether buses are early, on time, or late; monitor bus operations; and enhance safety and security. They can provide priority for BRT at signalized intersections, expedite fare collection, and provide guidance control and precision docking. Ideally, BRT should mirror rail transit in the use of ITS technology.

The main ITS elements for BRT include the following:

- Automatic vehicle location and control (AVLC), which includes provisions for safety and security;
- Passenger information;
- Traffic signal priorities;
- Automated passenger counting;
- Electronic fare collection; and
- Vehicle guidance and control.

Figure 7-1 shows how some of these ITS elements interface with buses, and Table 7-1 provides potential applications for BRT. Most BRT systems have some ITS applications. In places where ITSs have been most successfully applied to BRT, such as in Los Angeles, ITS elements have been part of a geographically larger, functionally comprehensive ITS system.

This chapter describes the main types of ITS technologies and their BRT applications. It draws from and extends the information contained in *Advanced Public Transportation Systems: The State of the Art: Update 2000* (Casey et al., 2000); the National Transit Institute's *ITS for Transit: Solving Real Problems* (Draft Participant's Manual) (2002); and *Benefits Assessment of Advanced Public Transportation System Technologies* (Goeddel, 2000).

### 7-1. AUTOMATIC VEHICLE LOCATION

AVL is an integrated part of BRT fleet management. Bus tracking uses AVL to pinpoint a bus's location on the street network. It allows real-time monitoring of a bus's move-

ments, control of bus headways, closer schedule adherence (including more effective timed transfers), and the ability to direct maintenance crews in the event of a vehicle breakdown. It also gives agencies the opportunity to provide real-time bus schedule information to patrons at stops and via the Internet on computers, personal digital assistants, and cell phones. AVL systems also allow two-way communications between bus drivers and central supervisors.

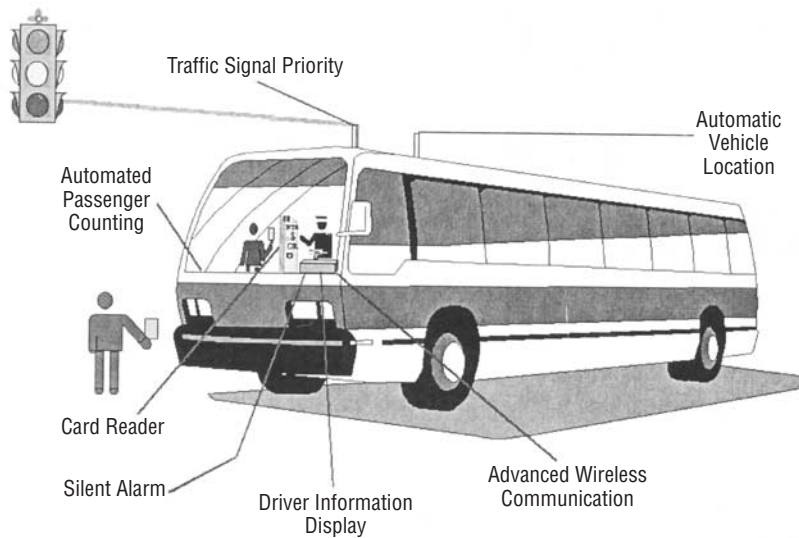
AVL systems can incorporate passenger information systems, identification for traffic signal controllers, automatic passenger counters, and silent security alarms for operator emergencies. AVL also allows transit agencies to monitor the mechanical condition of buses on the road. It usually contains some form of management reporting system.

These features make AVL an essential part of any BRT system. Accordingly, most existing and planned BRT systems incorporate or will incorporate AVL systems.

Benefits of AVL to transit agencies and BRT include the following:

- Improved dispatch and operated efficiency;
- Improved overall reliability of service;
- Quicker responses to disruptions in service such as vehicle failure or unexpected congestion;
- Quicker response to threats of criminal activity (via silent alarm activation by the driver);
- Extensive information provided at a lower cost for planning purposes, including information on passenger loads and travel patterns; and
- Rapid rerouting of buses when running ways are blocked.

AVL systems require three components: (1) a method of determining vehicle location, (2) a means of communicating the vehicle's location to a main center, and (3) a central processor to store and manipulate the information. Typical components of an AVL system are shown in Photo 7-A. AVL systems normally come equipped with a mobile data terminal for the driver to communicate with the dispatch center and to get direct feedback on on-time status. The dispatch center usually contains one or more staffed dispatch stations. Each dispatcher usually has two screens: one with a computerized map showing the current locations and status of all vehicles in service (covered by the AVL) and one that can display a variety of information, including communications with other drivers.



(SOURCE: Casey et al., 2000)

*Figure 7-1. Fleet management systems.*

**TABLE 7-1 Potential BRT applications of ITS technologies**

- 
- AVL systems can provide information to improve schedule adherence and reduce headways.
  - AVL systems can provide command center control to guarantee swift movement between feeder and express vehicles.
  - Real-time passenger information systems can give up-to-date information at home, office, or station through kiosks, automated signs, and the Internet.
  - Automated on-board information (voice and visual) systems can give information to passengers on stops, transfer points, and local attractions. Alternatively, they may be used for news, weather forecasts, and other information that would be helpful to passengers.
  - Automated traffic signal priority control systems can speed the movement of buses through intersections.
  - Video surveillance and covert emergency systems can guarantee the safety of customers on board vehicles and at load points and parking facilities.
  - Electronic passenger counting systems can provide readily retrievable information on use of stations by bus, by time of day, and by direction of travel.
  - Sensors can monitor mechanical and electric systems to ensure that problems are identified and that needed replacement vehicles are dispatched with minimum system disruption.
  - Smart cards can provide pre-boarding fare collection and be used on buses and in adjacent parking facilities.
  - Automated docking systems can expedite the loading and unloading of passengers to increase convenience and reduce dwell times.
  - Adaptive cruise control or automated guideway operation can decrease headways and expedite service.
  - Automated ramp control systems can speed the movement of buses onto freeways or dedicated lanes.
-



Driver with Mobile Data Terminal



Mobile Data Terminal



Dispatch Center

(SOURCE: Casey et al., 2000)



AVL Dispatch Station

*Photo 7-A. Applications of ITSs.*

### 7-1.1. Location Technology

The choice of location technology depends greatly on the specific agency needs and where the system will be installed. Location technologies are usually one of the following, but they can be used in combination:

- Global positioning system (GPS);
- Signpost and odometer interpolation, both active and passive;
- Dead reckoning; and
- Ground-based radio, such as LORAN-C.

The advantages and disadvantages of the various available location technologies are set forth in Table 7-2. A description of principal technologies follows.

#### 7-1.1.1. GPS

GPS is the most widely used location technology, accounting for about three-quarters of all AVL systems in the United

States. Figure 7-2 provides an example of an AVL system using GPS with odometer interpolation when GPS signals are not available. GPS uses satellites to locate objects on the earth's surface. Like LORAN-C, GPS uses triangulation to locate objects. One big advantage of GPS is that it can cover a wide area with minimal equipment; a vehicle requires only an on-board device to detect overhead satellites. A disadvantage is that GPS may have trouble in natural canyons, in the "urban canyons" of CBDs in major cities, and in tunnels. A dead-reckoning sensor can be added to overcome these blind spots.

An emerging system is the Nationwide Differential GPS that has 3- to 10-meter accuracy. This system is already available along U.S. coasts, major waterways, and in Hawaii and Puerto Rico. Tests of AVL using Nationwide Differential GPS have been conducted on the Acadia National Park transit system.

#### 7-1.1.2. Signpost/Sensor System

This system uses fixed transmitting signposts that are detected by passing vehicles. The signpost's transmitter signals are used to determine the vehicle's position, which can then

**TABLE 7-2 Synopsis of location technologies**

Technology	How it Operates	Advantages	Disadvantages
Signpost & Odometer- “active”	Signposts (beacons) are located at specific points along the route, each signpost transmitting a unique signal. Vehicle reads signals to determine location. (Vehicles usually interpolate between signposts, using their own odometer readings.) Vehicles send location data to dispatch.	<ul style="list-style-type: none"> <li>• Proven, well-established technology</li> <li>• Low in vehicle</li> <li>• No blind spots or interference</li> <li>• Repeatable accuracy</li> </ul>	<ul style="list-style-type: none"> <li>• Need signposts wherever AVL is to operate</li> <li>• Not effective for vehicles off-route or paratransit</li> </ul>
Signpost & Odometer- “passive”	Each vehicle transmits a unique signal to various signposts, located at specific points along the route (or signposts read transponders affixed to the vehicles). The signposts then transmit the vehicle’s location to dispatch.	<ul style="list-style-type: none"> <li>• Proven, well-established technology</li> <li>• Potentially reduces the number of dedicated radio frequencies required.</li> </ul>	<ul style="list-style-type: none"> <li>• Need signposts wherever AVL is to operate</li> <li>• Location only given when vehicle passes signpost</li> <li>• Not effective for vehicles off-route or paratransit</li> </ul>
GPS and Differential GPS	A network of satellites in orbit transmits signals to the ground. Special receivers on each vehicle read the signals available to them and triangulate to determine location. If the agency expects there to be long periods between GPS readings, they are sometimes supplemented with odometer readings or even more extensive dead reckoning.	<ul style="list-style-type: none"> <li>• Can be operated anywhere GPS signals can be received</li> <li>• Does not require purchase, installation, or maintenance of wayside equipment</li> <li>• Very accurate (especially differential GPS)</li> <li>• Moderate cost per vehicle</li> </ul>	<ul style="list-style-type: none"> <li>• Signals can be blocked by tall buildings, tree cover, tunnels, or overpasses</li> <li>• May be subject to multi-patch errors</li> </ul>
Ground-Based Radio (e.g., LORAN-C)	Network of radio towers on the ground transmits signals. Special receivers on each vehicle read the signals available to them and triangulate to determine location. Ground-based radio is sometimes supplemented with odometer readings for interpolations between signal receptions.	<ul style="list-style-type: none"> <li>• Can be operated anywhere signals can be received</li> <li>• Does not require purchase, installation, or maintenance of wayside equipment</li> <li>• Low capital and maintenance costs</li> <li>• Moderate accuracy</li> </ul>	<ul style="list-style-type: none"> <li>• Can be blocked by hills and tall buildings.</li> <li>• Incomplete coverage in the United States</li> <li>• Monthly service fees can be high</li> </ul>
Dead-reckoning	The vehicle uses its own odometer and a compass to measure its new position from its old (known) position. Dead-reckoning is often supplemented by “map-matching”- Comparing expected position if the vehicle is not on a road. Dead-reckoning is often supplemented with readings from another location technology, like signposts or GPS.	<ul style="list-style-type: none"> <li>• Requires no or significantly less purchase and maintenance of equipment if signposts are used as a supplement</li> <li>• Relatively inexpensive</li> <li>• Self-contained on vehicles</li> </ul>	<ul style="list-style-type: none"> <li>• Not as accurate as other location technologies without supplements</li> <li>• Accuracy degrades with distance</li> <li>• Requires direction indication and map matching to track vehicles off-route.</li> </ul>

SOURCE: Adapted from Casey et al., 2000.

be relayed back to a central control location. When there are no signposts, buses use their odometers to measure the distance from the last signpost. The bus’s location is communicated by radio frequency to a central processor, which updates the dispatcher, who can communicate with the driver about his/her progress.

#### 7-1.1.3. Dead Reckoning

This technology uses the bus odometer and on-board compass to compute its location. Starting from a known position, the system computes the distance and direction traveled and then fine-tunes its estimated new position by comparing it with a road map database stored in the vehicle. To correct

any location errors that accumulate, it also takes readings from strategically located signposts. The system is the least accurate of systems discussed.

#### 7-1.1.4. LORAN-C

This system was originally developed for the United States Coast Guard. Ground-based transmitters, which are already in place, emit a signal that is picked up by buses equipped with LORAN-C receivers, which determine the signal’s direction. Buses receive signals from several transmitters and triangulate their positions from three reference points. This system works regionwide, rather than just along routes. However, local topography can cause problems and dead spots.

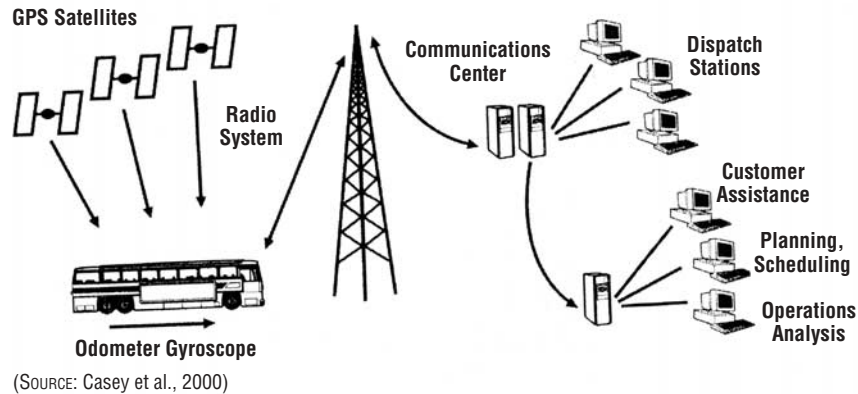


Figure 7-2. Schematic of an AVL system used in a transit agency.

## 7-2. PASSENGER INFORMATION SYSTEMS

ITS can provide dynamic (real-time) information to passengers before trips; at stations, stops, and terminals; or on a vehicle. Many of the automated passenger information features associated with rail transit systems can and should be applied to BRT. Passenger information systems for BRT should include all methods of informing the public about the service. Both the type of information available and how it is provided are important. Both affect the public's understanding of the system and ease of use. Bus information systems also can affect BRT perceptions and ridership.

Traveler information can be either static (e.g., the transit schedule, fares, and routes) or dynamic (e.g., delays and actual arrival/departure information). A complete BRT information system should utilize a variety of static and dynamic traveler information devices. Furthermore, each type of information can be delivered in a variety of ways including timetable dispensing kiosks, telephones, and displays for static information and variable message signs, radio and television broadcasts, hand-held computer devices, home computers, and mobile phones for dynamic information. Real-time information generally can be classified into one of three groups: (1) pre-trip information; (2) stop, station, and terminal information; and (3) on-board information.

### 7-2.1. Pre-Trip Information

Most North American BRT systems have a telephone-based information system that allows patrons to obtain schedule and route information. Systems may also have automated telephone systems through which information is provided based on input from the telephone keypad. Most transit agencies also make trip planning information available via the Internet.

Several BRT systems have implemented advanced real-time systems that provide patrons with information on when buses will actually arrive and/or depart. Some even provide the actual location of buses. This information is delivered over fixed and mobile phones; through interactive computer

terminals at kiosks; and over the Internet to portable computers, personal digital assistants, and other such devices.

### 7-2.2. Stop, Station, and Terminal Information

At a minimum, BRT stops, stations, and terminals should provide route numbers, static schedule information, and route maps. Several BRT systems, such as Boston's Silver Line, Los Angeles's Metro Rapid, Ottawa's Transitway System, Brisbane's South East Busway, and Vancouver's B-Line provide real-time information at stations.

Passenger information may come from video monitors or variable message signs, depending on the application and need for security. Monitors can be used when a large amount of information is being displayed and when there is a need for color and graphics to explain various options (e.g., in terminals). Variable message signs are more appropriate when information about a few buses is needed and security is an issue (e.g., at remote bus stops). Passengers may also get information at load points from mobile devices, personal digital assistants, and other wireless devices.

Figure 7-3 shows the Service Area Traveler Information Network that is used in the New York City area to provide information on traffic conditions, bus returns and schedules, weather, tourism, and park-and-ride. The system was installed at major bus terminals and transit centers. Costs for a 20-kiosk system were \$1.3 million. Figure 7-4 shows the Transit Watch Screen used at Seattle's Northgate Transit Center. The screen identifies bus routes, destinations, scheduled bus departures and loading bays, and departure status.

Recent applications of BRT in Los Angeles and Vancouver have included "next bus" departure information in real-time. Variable message signs provide real-time information for the next bus (see Photo 7-B). Real-time transit information used for light, heavy, and commuter rail systems, such as variable message signs or video monitors, may be applicable to BRT systems. Traveler information is typically provided at stations and transit centers. King County Metro in Seattle has placed video monitors with real-time bus departure




(SOURCE: Casey et al., 2000)

Figure 7-3. Satin kiosk screen.

Applet Viewer: its.app.twatch.applet.TransitWatch

Applet

 **Northgate TC** 10:48 AM  
Tue Mar 02

Route	Destination	Scheduled	At Bay	Depart Status
5	Downtown Seattle	10:45 AM	6	On Time
16	Northgate	10:41 AM	2	On Time
16	Seattle Ferry Term	10:42 AM	6	Bus Departed
16	Northgate	11:01 AM	2	No Info Avail
16	Seattle Ferry Term	11:02 AM	6	On Time
41	Northgate	10:44 AM	2	Bus Departed
41	Downtown Seattle	10:50 AM	5	27 Min Delay
66E	Northgate P & R	10:55 AM	2	On Time
66E	Downtown Seattle	10:55 AM	5	On Time
67	Northgate P & R	10:41 AM	2	18 Min Delay
67	UW Campus	10:42 AM	5	Bus Departed
67	Northgate P & R	11:11 AM	2	1 Min Delay

**Save Time. Buy a Metro Pass. 624-PASS**

Last update: Tue Mar 02 10:47:43 PST 1999

(SOURCE: Casey et al., 2000)

Figure 7-4. Sample transit watch screen flow—Northgate transit center.





Photo 7-B. Off-board passenger information, Metro Rapid, Los Angeles.

information in secure locations at several transit centers in the county.

### 7-2.3. On-Board Information

A traditional on-board information system consists of printed timetables and driver announcements. Improvements in technology have allowed stop announcements to be delivered by automated voice recordings or some type of message display. These systems can also announce transfer opportunities and local attractions. Some systems carry advertising messages to help cover the costs involved.

Several BRT systems have automated station announcements on vehicles. They include the Boston Silver Line, the Ottawa Transitway System, Pittsburgh's busways (on some buses), Brisbane's South East Busway, Rouen's BRT, and Curitiba's median busway system. Photo 7-C



Photo 7-C. On-board passenger information, Paris, Val-de-Marne (Trans Val-de-Marne).

shows the passenger information provided on buses using the Val-de-Marne BRT in Paris.

### 7-2.4. Summary

A BRT system should provide information for pre-trip planning and at stations and on buses. A BRT patron should be able to access trip planning and real-time system information while at work, on the computer, or using a wireless device. Once at a station or stop, real-time information should be available to tell the patron the current status of the system. Finally, on-board automated voice recordings or message displays should provide information on where to get off the bus. The passenger should be provided with real-time information on the status of bus routes at every stage of the trip.

## 7-3. TRAFFIC SIGNAL PRIORITIES

Traffic signal priority is an ITS strategy that gives buses preference at signals, whenever they arrive at an intersection, or only under certain conditions (e.g., when buses run late). As described in Chapter 4, signal prioritization can reduce the mean and variance of bus delays with minimum impacts on cross street traffic. The number of signal applications for BRT priority continues to increase. BRT systems in Los Angeles, Vancouver, and Rouen, and under development along Line 22 in Santa Clara and Euclid Avenue in Cleveland provide (or will provide) preference to BRT vehicles.

### 7-3.1. Techniques

Buses can communicate with traffic signals in several ways, including a sonic or optical pulse. One promising future application is allowing AVL systems to interact with traffic signals. The basic steps of signal prioritization include initiating a bus call, communicating between the bus and the traffic signal, and then implementing traffic signal control intelligence (signal timing that changes the intersection timing, thereby providing priority). Implementing signal priority requires traffic signal controllers that can distinguish between a priority call from a bus and a preemption call for an emergency vehicle; proper control algorithms are essential.

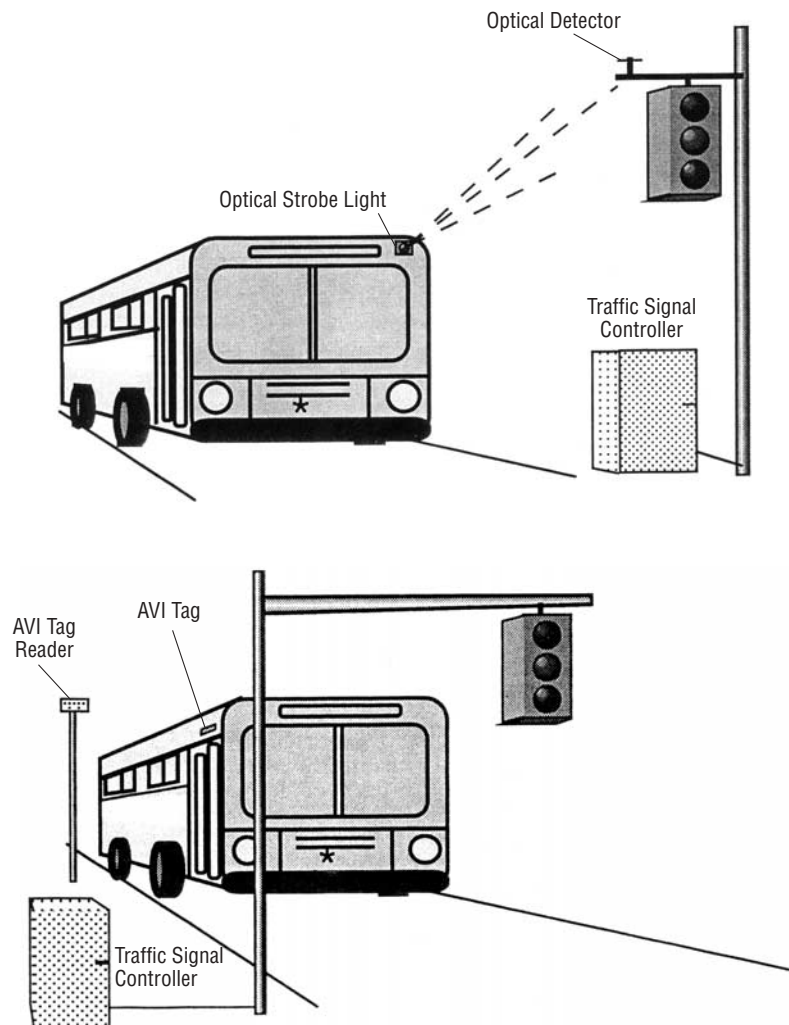
A wide range of system architecture is used for bus priority in cities around the world. Systems are evolving in complexity and functionality from transponder- and tag-based systems providing local priority to all buses, to more integrated AVL/Uniform Traffic Control systems. The latter systems often offer real-time fleet management, passenger information at bus stops, and "differential" priority for buses at traffic signals in an effort to improve bus regularity and reliability, as well as increase operating speeds.

Table 7-3 cites the advantages and disadvantages of various detection technologies. Many of the early installations used optical scanning or loop detection keyed to specific locations. Figure 7-5 illustrates optical and tag priority systems. There is

**TABLE 7-3 Advantages and disadvantages of various vehicle detection technologies**

Technology	Suppliers	Features	Advantages	Disadvantages
<b>Low Frequency RF (100–150 KHz)</b>	MFS; Detector Systems/LOOPCOM; Vapor VECOM through Vapor; Vapor VECOM through LSTS	Uses inductive radio technology with transmitters on vehicles and other standard loop detectors or antennas embedded in the road; transmitter factory programmed or interfaced from onboard keypad	Transmitters are inexpensive and are easily removed or replaced	Message transmission may be hindered by accumulated dirt or snow on tag
<b>Radio Frequency @ 900–1000 MHz</b>	TOTE/AMTECH; AT/COMM	Uses transmitter tags mounted on the side or vehicle top and antennas mounted roadside or overhead; historically used in toll collection, rail car, and containerized cargo ID; requires FCC registration	Transmitters are inexpensive and are easily removed or replaced; can transmit much information	Message transmission may be hindered by accumulated dirt or snow on tag
<b>Spread Spectrum Radio</b>	Automatic Eagle Signal/Tracker System; Econcile/EMTRAC	Sweeps narrow band signal over broad part of frequency spectrum; uses transmitter with directional antenna, and an electronic auto compass in each priority vehicle and receiver with omni-directional antenna at each intersection	Can transmit much information	Not as accurate in locating buses as other radio frequency technologies; can be affected by weather; may be more expensive
<b>Infrared</b>	Siemens/HPW infrared	Uses signpost on the side of the road to pick up and read signals; most common AVI technology for European bus priority systems	Well-proven in Europe	Limited ability to provide precise vehicle information; limited amount can be transmitted from vehicle; requires line of sight
<b>Video</b>	Racal Communications video with ALPR software	Video camera equipped with Advanced License Plate Recognition Software		Requires line of sight
<b>Optical</b>	3M/Opticom	Uses light emitter attached to transit coach and different frequency than emergency vehicles which have high priority	Potential advantages if intersections are already equipped with Opticom emergency preemption equipment	Limited ability to provide precise vehicle information and transmit from vehicle; requires line of sight
<b>Vehicle Tracking</b>	IBM/Vista System; TDOA & FDOA Tracking	Uses time difference of arrival and frequency difference of arrival to locate and track radio frequency transmissions from the vehicle's emitter		Buildings may block signal; may not provide precise location information for signal priority treatment

SOURCE: "Transit Priority Systems Study—Summary Report," 1994.



(SOURCE: Rutherford et al., 1995)

*Figure 7-5. Examples of bus detection.*

a clear trend toward using GPS to perform the location function. This enables the bus priority systems to be integrated with the master urban traffic control systems. Figure 7-6 shows how AVL relates to signal priorities at controllers.

Centralized AVL-related systems work in two basic ways. In the first method, bus detection is relayed to a traffic control center and a computer message is sent to the local signal controller. In the second method, GPS location and schedule adherence information are sent to the transit control management center, and a priority request is then submitted to the traffic control center. In both cases, priority is then granted or denied to the local signal controller. Several examples are described below.

7-3.1.1. Vancouver’s #98 B-Line

Vancouver’s #98 B-line rapid transit is one of the first to use the Novax Bus Plus™ System (“Bus Plus™ Traffic Signal Priority System,” n.d.). This system uses vehicle transponders that emit an infrared priority signal from a designated bus to identify it as a priority vehicle. Wayside units mounted near selected intersections detect the buses and then pass signals on to master units. The master units provide timely overrides to the traffic signal controller to expedite the passage of the designated buses through the selected intersections (“Bus Plus™ Traffic Signal Priority System,” n.d.). Photo 7-D shows a bus getting priority for a left turn.



Photo 7-D. Traffic signal priority, Vancouver B-Line.

7-3.1.2. Los Angeles Transit Priority Signal System

Los Angeles Metro Rapid’s Transit Priority System provides communications between antenna loops embedded in the pavement and transmitters mounted on buses. Information is sent to the city’s control center, from which messages are sent to individual controllers (Levinson et al., 2003).

A bus priority system along the portions of the Wilshire-Whittier and Ventura Boulevards BRT routes in the City of Los

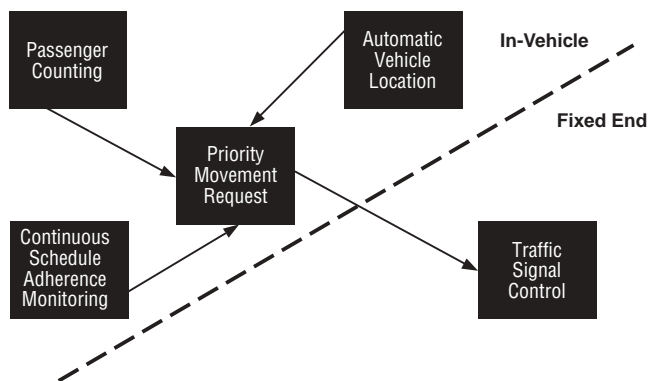
Angeles gives late buses additional green time (Levinson et al., 2003). Buses are given preference at most signalized intersections where the signal green time may be advanced or extended up to 10% of the signal cycle whenever a bus approaches. Cycle lengths range from about 70 to 90 seconds, with longer cycles in a few locations. At important intersections, the green light can be extended only in every other cycle. To prevent drivers from speeding up to extend the green time, early buses are not given priority.

The system is based on communications between antenna loops embedded in the pavement and transmitters mounted on buses. The automatic bus detection using loops and transponders was designed to reduce bus delay, maintain bus spacing, and simultaneously minimize impact on cross traffic. Real-time communication with the Los Angeles central urban traffic control system is once per second.

A key objective of this system was to maintain uniform headways between successive buses. The Transit Priority System was designed and implemented by the City of Los Angeles Department of Transportation. This program has gained nationwide attention since its debut on June 24, 2000, and has significantly improved the quality of transit operations along the two Metro Rapid corridors.

The Transit Priority System is an enhancement to the city’s Automated Traffic Surveillance and Control (ATSAC) system. This concept was embraced by the Los Angeles Metropolitan Transportation Authority and became an integral part of its Metro Rapid program. The system has been deployed at more than 211 intersections along the two Metro Rapid corridors in Los Angeles, Ventura Boulevard and Wilshire/Whittier Boulevards.

The Transit Priority System also includes control of dynamic passenger information signs at selected bus shelters along the Metro Rapid routes. These highly visible light-emitting-diode signs inform passengers of the estimated arrival times of the “next” Metro Rapid bus. The arrival time information is computed by the system based on the actual speed of the



(SOURCE: ITS for Transit: Solving Real Problems, 2001)

Figure 7-6. Traffic signal priority treatment keyed to AVL.

bus, is accurate to within 1 minute, and is relayed to the respective stations using technology similar to that used in cellular telephones.

The Los Angeles Metro Rapid also employs automatic traffic surveillance and control technologies. Each signalized intersection in the project is equipped with loop detectors that serve as AVI sensors. These sensors, embedded in the pavement, receive a radio-frequency code from a small transponder installed on the underside of a vehicle. Buses equipped with unique transponders are detected when traveling over the loop detectors. The loops are connected to a sensor unit within the traffic signal controller at each intersection, which transmits the bus identification number to the Transit Priority Manager computer in the city's ATSAC center at City Hall East for tracking and scheduling comparison. (See Photos 7-E and 7-F.)

Once the bus identification and location are received by the Transit Priority Manager, the computer determines the need for traffic signal priority. If the bus is early or ahead of the scheduled headway, no traffic signal priority treatment is provided. However, if the bus is late or beyond the scheduled headway, then the downstream traffic signal controller will provide priority to help the bus catch up with the scheduled headway. In addition, real-time data links from the Los Angeles County Metropolitan Transportation Authority dispatch center to the ATSAC center are used to obtain the daily bus assignment for schedule comparison.

Traffic signal control at each intersection is provided by a Model 2070 controller that is equipped with a state-of-the-art software program developed by the City of Los Angeles specifically for this project. Once the Model 2070 traffic signal controller receives a request from the Transit Priority Manager, it implements one of the four types of traffic signal priority actions depending on the point in time when the signal controller receives the commands relative to the background cycle. The four types of traffic signal priority are the following:

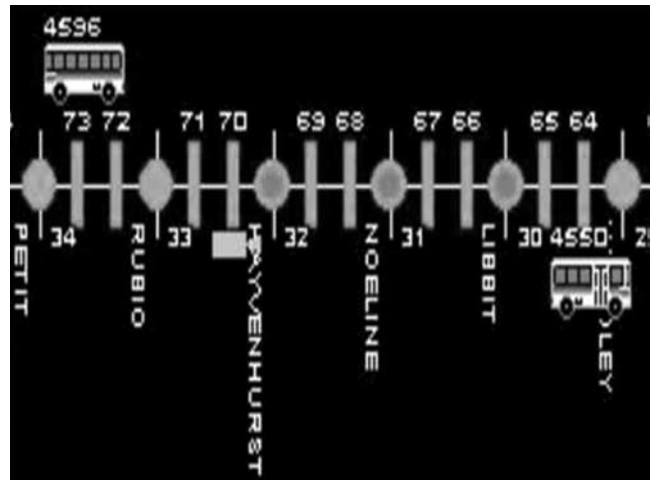


Photo 7-F. Control room bus location bus plan displays, Metro Rapid, Los Angeles.

- **Early Green** priority is granted when a bus is approaching a red signal. The red signal is shortened to provide a green signal sooner than normal.
- **Green Extend** priority is granted when a bus is approaching a green signal that is about to change. The green signal is extended until the bus passes through the intersection.
- **Free Hold** priority is used to hold a signal green until the bus passes through the intersection during noncoordinated (free) operation.
- **Phase Call** brings up a selected transit phase that might not normally be activated. This option is typically used for queue jumper operation or a priority left-turn phase.

#### 7-3.1.3. Benefits of Bus Priority Systems

Bus priority systems benefit BRT by reducing the average delays and the variability of delays at traffic signals. A wide range of bus travel time savings has been reported.

**FTA-Reported Studies.** A study prepared by the Los Angeles County Metropolitan Transportation Authority and summarized by the Federal Transit Administration analyzed 24 signal priority projects (Casey et al., 2000; Goeddel, 2000). Key results are summarized as follows.

- *Atlanta, Georgia.* This project covered 25 buses on one route. It shortened the red times for approaching buses. Average travel time inbound for the entire route went from 41.8 minutes before shortening red times to 28 minutes after the change (a 33% decline). In the outbound direction, the time went from 33.1 minutes before shortening red times to 27.5 minutes after the change (a 16.9% reduction).

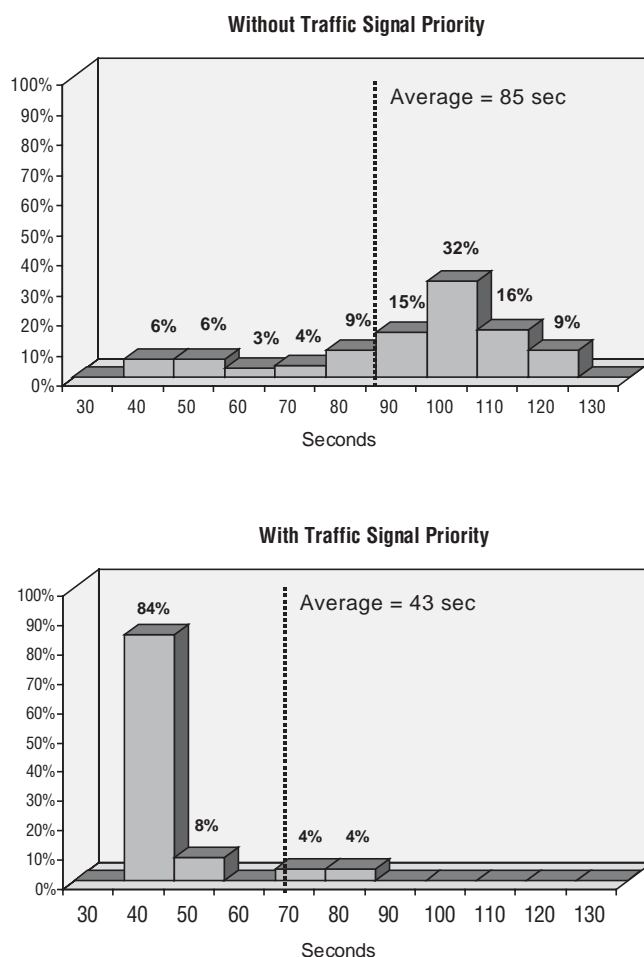


Photo 7-E. Central control room, Metro Rapid, Los Angeles.

- *Anne Arundel County, Maryland.* This test included 12 buses and 14 intersections. A 10-minute savings for a 52-minute trip was reported.
- *Pierce Transit, Tacoma, Washington.* This 3.1-mile-long project included 11 intersections and used 15 buses. A 6% average travel time reduction was reported.
- *Toronto Transit Commission, Ontario, Canada.* This study involved 10 buses traveling over 210 intersections. Travel times in peak period were reduced 2 to 4%.

**Recent Studies.** More recent benefits resulting from traffic signal priorities for buses are as follows:

- *Los Angeles.* Metro Rapid buses along Wilshire-Whittier Boulevards and Ventura Boulevard in Los Angeles achieved a 25% reduction in total travel time; signal priorities accounted for 30% of the savings—a 7.5% travel time reduction. There was a negligible increase in delays to cross traffic (“Bus Plus™ Traffic Signal Priority System”).
- *Portland, Oregon.* TriMet installed a bus priority system at 58 intersections along Bus Routes 4 and 104. Buses are given selective priority when they are over 90 seconds late. A 5 to 8% reduction in running time was reported. The technology used was TriMet’s Bus Dispatch System (an AVL system). An on-board GPS satellite receiver determines the bus location, and an Opticom emitter is actuated to initiate priority. All emergency vehicles have a “high-priority” setting that overrides transit’s low-priority setting (Klous and Turner, 1999; Chada and Newland, 2002).
- *King County, Seattle.* The King County Department of Transportation implemented signal priorities on 2.1 miles of Ranier Avenue in 2000. Five of nine intersections were given priority. The system hardware included Amtech RF radio frequency tags on buses. The a.m. peak period along Ranier Avenue experienced a 12-second (13%) reduction in average intersection delay. The intersections *with priorities* reduced the average intersection bus delay by about 5 seconds—a 24 to 34% reduction for buses getting priority. The priorities for buses produced minimal side street delay, and no side street vehicles had to wait more than one signal cycle (“Final Report,” 2001).
- *Bremerton, Germany.* Some 105 intersections in the bus service area were given traffic signal priorities. This resulted in reducing the fleet size by 10% (Greschner and Gerland, 2000).
- *Hamburg, Germany.* Traffic signal priorities were installed along a bus route serving the major Wansbek Market Rapid Transit Station. Both the bus travel speeds and reliability improved. (See Figure 7-7.) During the peak periods overall bus speeds increased from 20.8 kilometers per hour to 26.0 kilometers per hour, a 25% gain. During the off-peak periods, bus speeds increased from 22.3 kilometers per hour to 31.3 kilometers per hour, a 40% gain.



NOTE:  
Based on run times between two bus stops in Hamburg, Germany.

(SOURCE: Goeddel, 2000)

Figure 7-7. Distribution of run times between bus stops Rodigalles and Schifteker Weg, Hamburg, Germany.

Before priorities, the time to pass the Rodigalles and Schifteker Weg intersections averaged 85 seconds; 32% of the buses needed 100 seconds. With priorities at signals, the average travel time reduced to 43 seconds; 84% of the buses needed only 40 seconds. The *range* in travel times was 90 seconds before priorities and 50 seconds after—a dramatic decline in running time variability.

#### 7-4. AUTOMATIC PASSENGER COUNTERS

Automatic passenger counters (APCs) count passengers automatically when they board and alight buses. These systems are used to develop or refine bus schedules or to plan or support service changes (Table 7-4). They can greatly reduce the cost of collecting ridership information by reducing or eliminating the need for manual checkers. APCs can also increase the amount and quality of information obtained and

**TABLE 7-4 Uses for APC systems**

Uses for Collected Data	Number of Systems
Create / Evaluate / Adjust Run Times / Schedules	14
Plan / Justify Route Changes	13
Evaluate Marketing Strategies	3
Estimate Expected Revenue	1
Determine Fleet Needs	2
Monitor Driver Performances	3
Determine Location of Stop Facilities	5
NTD (formerly Section 15) Reporting	6
Other	2

NOTE: Based on 25 agencies surveyed.  
 SOURCE: Baltes and Rey, 1998.

can permit continuous sampling of stop-by-stop ridership on each BRT vehicle so equipped.

APCs typically use either treadle mats or infrared beams. Treadle mats placed on the steps of the bus register passengers as they step on a mat, and infrared beams (mounted either horizontally or vertically) directed across the path of boarding and alighting passengers register riders when they break the beam. Typically, two mats or two beams are put in succession so that a boarding passenger triggers them in a different order than does an alighting one, allowing the APC to distinguish between boardings and alightings. Other counting technologies, such as those employing computer imaging, are being developed. Figure 7-8 illustrates a hypothetical APC system and shows how the various components such as GPS or radio signposts relate to the passenger counting unit.

An electronic record is created at each bus stop that typically includes information on stop location, date and time, time of doors opening and closing, the number of passengers boarding, and the number of passengers alighting. These records are grouped by trip and are usually held in storage on the vehicle until they are downloaded to a central facility for further processing and use in operations, planning, and management. Ideally, the APC system is linked to an operational AVL system employed by the same agency to pinpoint vehicle locations.

**7-5. ELECTRONIC FARE COLLECTION CARDS**

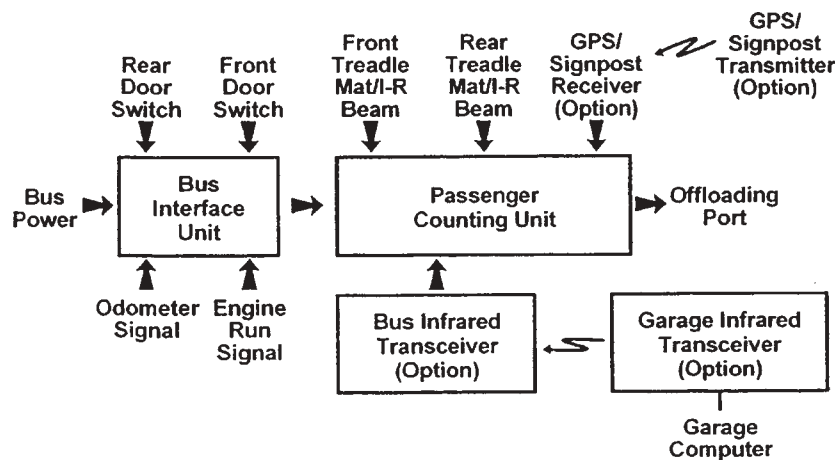
Fare payment methods can affect the overall success of a BRT operation by increasing passenger convenience and operation efficiency. New fare systems may serve to attract new passengers and retain existing passengers, whereas cumbersome methods may inhibit ridership and hamper bus operations. Fare payment methods also affect the bus driver directly: some methods are time consuming, distracting, and can lead to driver-passenger disputes.

In addition, ITS-based electronic fare payment systems can allow an agency to collect information about ridership for use in planning and operations. Transit agencies using these systems add flexibility to establishing fares, help reduce collection costs and theft, and increase revenue by using the “float” on prepaid fares and reducing fare evasion. Table 7-5 describes the advantages and disadvantages of various fare collections media, including cash and tokens, paper passes and tickets, magnetic stripe cards, and “smart cards.” Smart cards have emerged as the preferred option, and will be more attractive as their costs go down.

The implementation of electronic fare payment systems has increased rapidly in the past 6 or 7 years, and several surveys have documented dramatic increases. An FTA report on the benefits of advanced technologies for public transportation cites survey results in which operational deployments increased 96% from 1996 to 1999, and planned fare systems increased 265% for that same time period (Goeddel, 2000).

**7-5.1. Types of Cards**

Several different types of smart cards may be used for fare collection, including debit cards, credit cards, and magnetic stripe fare cards. The FTA report cited above reports the following distribution of cards in use, under deployment, or planned (Goeddel, 2000):



(SOURCE: Casey et al., 2000)

Figure 7-8. Illustration of a hypothetical APC system and related components.

**TABLE 7-5 Fare media advantages and disadvantages**

Advantages	Disadvantages
<b>Cash and tokens:</b> Simplest form of payment Most widely used	<b>Cash and tokens:</b> Most expensive form of payment to process Highly susceptible to theft High exposure to fraud State-of-the-art cash and token collection equipment is complex
<b>Paper passes and tickets:</b> Inexpensive to purchase stock Easily combined with other payment technology, such as magnetic stripe and optical coating	<b>Paper passes and tickets:</b> Susceptible to fraud Labor intensive Pre-printed stock needs to be treated like a currency
<b>Magnetic stripe cards:</b> Proven technology Inexpensive media Can be combined with printing Support a high number of uses	<b>Magnetic stripe cards:</b> Require complex equipment Maintenance intensive Susceptible to accidental erasure Have a large variance in reliability More susceptible to fraud than smart cards
<b>Smart Cards:</b> Secure data transfer No physical connection required for contactless applications Larger memory capacity Can perform complex security validation calculations (microprocessor card) Highly reliable High resistance to fraud	<b>Smart Cards:</b> Cost—prohibits use for single ride

SOURCE: Casey et al., 2000.

- Unknown: 14% (not yet selected);
- Magnetic Stripe Cards: 35%;
- Smart Cards: 40%;
- Debit Cards: 4%;
- Credit Cards: 7%.

#### 7-5.1.1. Magnetic Stripe Cards

Magnetic stripe cards, which were first used for the Bay Area Rapid Transit District in San Francisco in 1972, eliminate the need to put cash in a farebox. The patron simply runs the card through a reader and the magnetic stripe stores the value left on the card or in some cases just indicates that the card is valid. The cards have the advantage of simple technology, a proven track record, and the ability to be purchased prior to boarding.

#### 7-5.1.2. Smart Cards

Smart cards are replacing magnetic stripe cards as the fare collection system of choice in many recent applications. The cards look similar to standard credit cards and are equipped with a programmable memory chip that performs several functions: holding instructions, holding value, self-monitoring, and creating an electronic billing record (Casey et al., 2000).

Smart cards have several advantages over magnetic stripe cards. They cannot be erased accidentally, and they can be identified by an electronically unique internal serial number and cannot be duplicated fraudulently. In addition, they can

register the fare by touching a certain location on the fare collection device using an active or passive radio signal. Some smart card systems use a distance-based fare scheme, with the exact fare calculated after one person's card is read by the fare device on the way in and out of the vehicle.

#### 7-5.1.3. Credit and Debit Cards

Small financial transactions are becoming attractive to credit card companies. Enabling the use of credit or debit cards as a transit fare collection device has numerous advantages. Transit agencies can avoid the costs of fare card distribution, advertising, billing, as well as fraud responsibilities. This arrangement also increases the potential ridership pool to *all* credit card holders, including infrequent riders and visitors from outside the transit service area.

The disadvantages are mostly institutional, in that public and private companies do not have a history of cooperative ventures of this type. When credit and debit cards are used, the cards might contain two systems, one with a magnetic stripe for normal sales transactions, and the other a contactless chip for the transit system transaction.

#### 7-5.2. Reported Benefits

A study conducted for the Washington Metropolitan Area Transit Authority concluded that electronic fare systems support numerous objectives, including the following (Multi-systems, 2001):

- Improved travel time through faster boarding,
- Improved coordination within a region using the same card,
- Creation of a more seamless network with one card,
- Improved operational efficiency, and
- Increased ridership potential with added convenience and less confusion.

The financial advantages of fare collection technologies are shown in Table 7-6.

**7-6. VEHICLE GUIDANCE**

Several ITS technologies available or under development are designed to assist transit operators in driving their vehicles more safely and, in some cases, can control the vehicle’s lane position automatically. These technologies can be employed along the entire running way or just at stations where precision docking is important to provide a small separation between the vehicle and the platform. Other guidance applications include tunnels and narrow running ways. These precision docking and collision avoidance technologies can be beneficial to BRT systems.

**7-6.1. Tight Maneuvering/Precise Docking**

Precision docking applications position a bus precisely relative to the curb or loading platform. The driver can maneuver the bus into the loading area and then turn it over to automation. Sensors continually determine the lateral distance to the curb, front, and rear, and the longitudinal distance to the end of the bus loading area. The driver can override the

system at any time by operating the brakes or steering and is expected to monitor the situation and take emergency action as necessary (e.g., if a pedestrian steps in front of the bus). When the bus is properly docked, it will stop, open the doors, and revert to manual control. Safer boarding and egress for people with disabilities, the elderly, and children are important considerations in developing these systems.

Guidance may be mechanical, optical, magnetic, or wire. For several decades, many manufacturers in Europe have been developing guided buses as an alternative to trains. Daimler-Benz developed the O’Bahn in 1970 for the Federal German Government. MATRA has developed an optical guidance system following a painted line on the road. Bombardier is using a single guidance system under the center of the road.

**7-6.2. Mechanical Guidance**

Mechanical guidance systems use physical contact between wheels attached to the vehicle and some type of curb that guides the vehicle’s path. The wheels are connected to the steering mechanism, which makes small adjustments based on the position of the vehicle and the curb. Mechanical guidance has been used in O’Bahn systems in Leeds, United Kingdom; Essen, Germany; and Adelaide, Australia, since the 1970s. In Leeds, it is used in queue jumps that are self-enforcing because of the technology. In Essen (a system that has since ceased operations), the O’Bahn shared a right-of-way with an LRT line. In Adelaide, the O’Bahn was selected because of its narrower right-of way and reduced cross sections (about 22 feet) in elevated structures (see Photo 7-G). Photo 7-H shows a BRT guideway with mechanical guidance in Leeds.

**TABLE 7-6 Financial advantages of electronic fare media**

Increase Revenue	Decrease Costs
Shorter processing time and use of conventional fare media may result in increased ridership.  Integration with other modes or operators may enable more customer discounts and loyalty schemes resulting in increase ridership and revenue.	Use of electronic fare media decreases cash/coin handling: <ul style="list-style-type: none"> <li>- cash/coins collected for fare payment (i.e., at farebox or fare gate) decreased or eliminated;</li> <li>- higher value ticket/fare sales transactions, resulting in fewer transactions.</li> </ul>
Increased transaction data permit equitable distribution of shared revenues and audit trail to protect against employee theft.	Automation of fare collection processes decreases labor costs.
Increased customer information permits optimization of fares, schedules, and transit service.	Use of products without mechanical/moving parts (e.g., ticket transports) increases equipment reliability, reducing maintenance.
Increased media security decreases fraud levels.	

SOURCE: Casey et al., 2000.





Photo 7-G. BRT guideway, Adelaide.

**7-6.3. Optical Guidance**

This technology uses machine vision cameras and related equipment to read the location of a painted pile on the pavement and keep the vehicle within the lane width provided. Examples of vehicles using this type of guidance are shown in Photos 7-I, 7-J, and 7-K.

**7-6.4. Magnetic Guidance**

This technology uses magnetic tape or plugs that are located on the surface of the guideway or drilled into the pave-



Photo 7-I. "Optical scanner" vehicle at station.

ment. The vehicle carries a sensor that measures the strength of the signal and uses that information to calculate the lateral position of the bus. The University of California Partners for Advanced Transit and Highways (PATH) Laboratory has been developing this technology for many years and has conducted several successful demonstrations.

**7-6.5. Wire Guidance**

In this application, a wire is embedded in the pavement, and an electric current passes through the wire. The current causes a magnetic field to be generated that can be used for guidance



Photo 7-H. BRT guideway, Leeds.



Photo 7-J. Optical guidance on a BRT vehicle.



Photo 7-K. Precision docking at stations with a BRT vehicle.

in a way similar to the magnetic system. The Bombardier BRT vehicles in Nancy, France, use a light duty track in the middle of a dedicated running way that guides vehicles under electric power. Vehicles can be steered like a bus when running on other rights-of-way under diesel power.

#### 7-6.6. GPS

GPS-based guidance systems can locate the position of a vehicle to within 2 to 5 centimeters. Knowing where the vehicle is requires precise knowledge of the location of the roadway lanes. If the roadway were fully described in a digital geospatial database, it would be possible to use this to provide vehicle guidance.

### 7-7. COLLISION AVOIDANCE SYSTEMS

Collision avoidance systems deal with the various ways to avoid bus collisions with other vehicles. There have been several operational tests, and performance specifications are

under development. There were no operating systems as of 2002 (*A Survey to Assess Lane Assist Technology Requirements*, 2002).

#### 7-7.1. Lane Change and Merge Collision Avoidance

These systems warn the transit driver of hazards, especially in the vehicle's "blind spot," where many accidents happen. More advanced applications provide information on vehicles in adjacent lanes based on their position and velocity and whether they pose a risk to a lane change or merge.

#### 7-7.2. Collision Avoidance

Technology can help avoid collisions in both the front and back of BRT vehicles. Radar can detect how the transit vehicle is approaching other vehicles and either warn the driver or automatically reduce the vehicle's speed to avoid the accident. Rear-end collisions with the transit vehicle can be reduced with visual warnings on the back of the bus.

### 7-8. BUS PLATOONS

Manually dispatched bus platoons operated on Chicago State Street Transit Mall in the 1980s and still operate in several South American cities. In bus platoons, electronic technologies enable buses to be electronically coupled with short headways and, in essence, operate as if they were a train. This could be desirable for high-speed, high-volume express BRT runs from a few outlying collection points to the downtown of a major city. It is a long-range opportunity for densely developed corridors that remains to be fully developed and tested operationally.

### 7-9. BENEFIT AND COST SUMMARY

General benefits resulting from various Advanced Public Transportation System programs are summarized in Table 7-7. These benefits also apply to BRT systems (*Automatic Vehicle Location*, 2000). Examples of benefits associated with AVL, passenger information, fare collection, traffic signal priorities, and vehicle guidance are discussed below.

#### 7-9.1. AVL

Several transit agencies have indicated that AVL systems reduce capital and operating costs and enhance ridership. In Kansas City, Missouri, the Kansas City Area Transportation Authority was able to reduce the number of buses serving its routes by seven vehicles. This translated into a capital cost savings of \$1,575,000 (\$225,000 per bus). Throughout the United States, AVL and computer-aided dispatching has reduced bus operating costs from 4 to 9%. Some agencies in

**TABLE 7-7 Summary of Advanced Public Transportation System (APTS) program benefits**

Fleet Management Systems	<ul style="list-style-type: none"> <li>• Increased transit and security</li> <li>• Improved operating efficiency</li> <li>• Improved transit service and schedule adherence</li> <li>• Improved transit information</li> </ul>
Operational Software and Computer-Aided Dispatching Systems	<ul style="list-style-type: none"> <li>• Increased efficiency in transit operations</li> <li>• Improved transit service and customer convenience</li> <li>• Increased compliance with ADA requirements</li> </ul>
Electronic Fare Payment Systems	<ul style="list-style-type: none"> <li>• Increased transit ridership and revenues</li> <li>• Improved transit service and visibility within the community</li> <li>• Increased customer convenience</li> <li>• Enhanced compliance with ADA</li> </ul>
Transit Intelligent Vehicle Initiative	<ul style="list-style-type: none"> <li>• Increased safety of transit passengers</li> <li>• Reduced costs of transit vehicle maintenance and repairs</li> <li>• Enhanced compliance with ADA</li> </ul>

SOURCE: Casey et al., 2000.

North America reporting a reduction in operating costs are the following:

- **Atlanta, Georgia.** The Metropolitan Transportation Area Regional Transportation Authority has saved \$1.5 million annually in operating costs because of the reduced need for schedule adherence and travel time surveys.
- **London, Ontario.** An AVL system saves London Transit from \$40,000 to \$50,000 (U.S. dollars) on each schedule adherence survey conducted.
- **Kansas City, Missouri.** By reducing its fleet size (as a result of implementing AVL), the Kansas City Area Transportation Authority realized maintenance expense savings of \$189,000 per year (\$27,000 per bus per year) and total labor cost savings of \$215,000 per year.
- **Baltimore, Maryland.** By the fourth to sixth year of operation, the Mass Transit Administration expects to save \$2 to 3 million per year by purchasing, operating, and maintaining fewer vehicles because of increased efficiencies provided by its AVL system.
- **Prince William County, Virginia.** The Potomac and Rappahannock Transportation Commission estimated an annual savings of \$870,000 because of its AVL system.
- **Portland, Oregon.** TriMet's AVL/computer aided dispatch (CAD) system produced an estimated annual operating cost savings of \$1.9 million, based on an analysis of eight routes that are representative of TriMet's service typology.

Some agencies reported other benefits of using an AVL system. Some of these are the following:

- **Denver, Colorado.** The Regional Transportation District observed a 5.1% increase in ridership between 1995 and

1996 and attributes the increase to its CAD/AVL system. Also, an AVL system with silent alarms supported a 33% reduction in bus passenger assaults. CAD/AVL reportedly decreased customer complaints and improved bus performance by 9 to 23%.

- **Milwaukee, Wisconsin.** Total revenue ridership increased 4.8% between 1993 and 1997 for the Milwaukee County Transit System. The agency attributes the improvement to its CAD/AVL system.
- **Toronto, Ontario.** The Toronto Transit Commission estimates that service improvements from its AVL system will conservatively result in a 0.5 to 1.0% increase in ridership.
- **Portland, Oregon.** From fall 1999 to fall 2000, week-day ridership increased by 450 for one route after TriMet used AVL data to adjust the route's headways and run times.

#### 7-9.2. Passenger Information

Improved passenger information has been beneficial for many transit agencies. Some examples are the following:

- **London, United Kingdom.** London Transport's ROUTES, a computerized route planning system, generated an additional estimated £1.3 million of revenue for bus companies, £1.2 million for the Underground, and £1 million for the railways from increased ridership.
- **Helsinki, Finland.** In a customer survey regarding a real-time transit vehicle arrival display system implemented on one tram line and one bus route, 16% of tram passengers and 25% of bus passengers reported that they increased their use of the line/route because of the displays.

**TABLE 7-8 Cost ranges for specific ITS technologies**

Subsystem/Unit Cost Element	IDAS No.	Lifetime (7 years)	Capital Cost (K)		Operating & Maintenance Cost (\$K per year)		Notes
			Low	High	Low	High	
1. Information Service / Provider Labor	IS004		Low	High	Low 175	High 250	2 Staff @ \$50–75K. Salary costs are fully loaded.
2. Vehicle Location Interface	TR007	20	10	15			Vehicle location interface
3. Transit Center Software, Integration	TR002	20	815	1720	6	12	Includes vehicle tracking & scheduling, database & information storage, schedule adjustment software, real time travel information software, and integration
4. Electronic Farebox	TV007	10	0.8	1.5	0.04	0.075	On-board flex fare system DBX processor, on-board farebox, and smart card reader
5. Trip Computer and Processor	TV005	10	0.1	0.15	0.002	0.003	On-board processor for trip reporting and data storage
6. Transit Center Hardware	TR001	10	15	30			Includes three workstations

NOTE: Costs are per bus for items 2, 4, and 5.

SOURCE: Joint Program Office for Intelligent Transportation Systems, 2002.

- **Turin, Italy.** An opinion survey regarding the provision of next-stop information on board transit vehicles revealed that 75% of customers found the system useful.

**7-9.3. Fare Collection**

Fare collection systems can create system savings through lower fare avoidance, reduced labor costs, and more efficient operations. For example, the MetroCard system saved New York City Transit \$70 million per year.

**7-9.4. Traffic Signal Priorities**

Travel signal priorities have typically resulted in a travel time savings of about 7 to 10%, although higher travel time savings have been reported. (See Section 7.3 for further discussion.)

**7-10. COSTS**

Capital and operating cost ranges based on the ITS Unit Costs Database are summarized in Table 7-8. Costs for vehicle location interface, electronic fareboxes, and trip computer and processors are given on a per bus basis. Generally, AVL systems cost up to about \$8,000 per bus, whereas advanced traveler information systems cost from \$2,000 to \$7,000 per bus. A TCRP study indicates that GPS-based AVL systems cost about \$13,700 per vehicle (Okunieff, 1997). Electronic fare collection currently costs \$7,000 to \$12,000 per bus.

**7-11. CHAPTER 7 REFERENCES**

*A Survey to Assess Lane Assist Technology Requirements* (Draft Report). Metro Transit Minneapolis and University of Minnesota,

ITS Institute, U.S. Department of Transportation, Federal Highway Administration (December 19, 2002).  
*Automatic Vehicle Location: Successful Transit Applications: A Cross-Cutting Study: Improving Service and Safety.* FHWA-OP-99-022/FTA-TRI-11-99-12. Joint Program Office for Intelligent Transportation Systems, FTA (2000).  
 Baltes, M. R. and J. R. Rey. “Use of Automatic Passenger Counters Assessed for Central Florida’s Lynx.” *CUTRLines Newsletter*, Vol. 9, No. 1 (1998).  
 “Bus Plus™ Traffic Signal Priority System.” Novax Industries Corporation, New Westminster, British Columbia, Canada (n.d.). [www.novax.com/products/media/Novax\\_BusPlus.PDF](http://www.novax.com/products/media/Novax_BusPlus.PDF).  
 Casey, R. F., et al. *Advanced Public Transportation Systems: The State of the Art: Update 2000.* DOT-VNTSC-FTA-99-5. U.S. Department of Transportation, Volpe National Transportation Systems Center (December 2000).  
 Chada, S., and R. Newland. “Effectiveness of Bus Signal Priority—Final Report.” National Center for Transit Research, Center for Urban Transportation Research, University of South Florida (June 2002).  
 “Final Report—Ranier Avenue South Transit Signal Priority Field Evaluation.” King County Metro, Seattle, WA (January 2001).  
 Goeddel, D. L. *Benefits Assessment of Advanced Public Transportation System Technologies.* DOT-VNTSC-FTA-00-02. U.S. Department of Transportation, Volpe National Transportation Systems Center (November 2000).  
 Greschner, J. T., and H. E. Gerland. “Traffic Signal Priority: Tool to Increase Service Quality and Efficiency.” *Proc., Bus and Paratransit Conference*, Houston, TX, APTA, Washington, DC (2000) pp. 138–143.  
*ITS for Transit: Solving Real Problems* (Draft Participant’s Manual). National Transit Institute, Rutgers University, New Brunswick, NJ (September 2001).  
*ITS for Transit: Solving Real Problems* (Draft Participant’s Manual). National Transit Institute, Rutgers University, New Brunswick, NJ (September 2002).  
 Joint Program Office for Intelligent Transportation Systems, U.S. Department of Transportation. ITS Unit Costs Database.

- [www.benefitcost.its.dot.gov/ITS/benecost.nsf/ByLink/Costhome](http://www.benefitcost.its.dot.gov/ITS/benecost.nsf/ByLink/Costhome). Accessed March 30, 2002.
- Klous, W. C., and K. R. Turner. "Implementing Traffic Signal Priorities for Buses in Portland." Presented at Transportation Frontiers for the Next Millennium, 60th Annual Meeting of the Institute of Transportation Engineers, Las Vegas, NV (August 1999).
- Levinson, H., S. Zimmerman, J. Clinger, S. Rutherford, R. L. Smith, J. Cracknell, and R. Soberman. *TCRP Report 90: Bus Rapid Transit, Volume 1: Case Studies in Bus Rapid Transit*. Transportation Research Board of the National Academies, Washington, DC (2003).
- Okunieff, P.E. *TCRP Synthesis of Transit Practice 24: AVL Systems for Bus Transit*. Transportation Research Board, National Research Council, Washington, DC (1997).
- Multisystems. *Intelligent Transportation Systems: Regional Bus Study*. Washington Metropolitan Area Transit Authority, Washington, DC (August 2001).
- Rutherford, G. S., S. MacLachlan, K. Semple. *Transit Implications of HOV Facility Design*, WA-RP-3961-1. Prepared for Federal Transit Administration by Washington State Transportation Center, Seattle, WA (September, 1995).
- "Transit Priority Systems Study—Summary Report." Parsons Brinckerhoff Quade & Douglas. Prepared for Intercity Transit (July 1994).
-

## CHAPTER 8

# BUS OPERATIONS AND SERVICE

BRT service should be clear, direct, frequent, and rapid. Service design should meet customer needs while also attracting new riders. Fares should permit rapid boarding of buses. Marketing should focus on BRT's unique features and further reinforce its identity. This chapter provides guidelines on these aspects of BRT operations.

### 8-1. GENERAL GUIDELINES

General guidelines for BRT service planning, fare collection, and marketing, which provide a starting point that may need adjustment in specific situations, are the following:

1. Service patterns and frequencies should reflect the city structure, types of running way, potential markets, and available resources.
2. Service should be simple, easy to understand, direct, and operationally efficient. Providing point-to-point service (one-seat rides) should be balanced against the need for easy-to-understand, high-frequency service throughout the day.
3. It is generally better to have few high-frequency BRT routes than many routes operating at long headways.
4. Through service—at least for basic all-stop routes—is desirable when the round trip can be made in 2 hours (3 hours maximum).
5. Busway route structure should include basic all-stop service complemented by express (or limited-stop), feeder, and connector service.
6. The basic all-stop service should run all-day, from about 6 a.m. to midnight, 7 days a week, and the express service should operate weekdays throughout the day or just during rush hours.
7. The basic BRT service should operate at 5- to 10-minute intervals during rush hours, and 12- to 15-minute intervals at other times.
8. Buses may run totally or partially on dedicated rights-of-way when such rights-of-way are available.
9. Emergency vehicles such as police cars, fire trucks, and ambulances should be given access.
10. BRT running ways may be used by all transit operators in a region where vehicles meet established safety requirements.
11. BRT routes can share running ways with HOVs in reserved freeway lanes when the joint use does not reduce travel times, service reliability, or BRT identity.
12. Public regulation of BRT operations may be needed when services are contracted or privately operated. Private sector operation under public supervision has proven successful in Curitiba, where public-private sector initiatives have resulted in an efficient, high-quality bus service.
13. Fares should be integrated with the rest of the bus system, but may not necessarily be the same.
14. Fare collection should facilitate multiple-door boarding, at least at major stops during busy periods. Off-board collection (preferred) or on-board multi-point payment should be encouraged.
15. Marketing activities should focus on the key attributes of BRT, such as service frequency, speed, comfort, and reliability.
16. Marketing activities should promote BRT identity by providing brochures, maps, schedules, and passenger information that are key to the overall theme of the BRT system.

### 8-2. SERVICE DESIGN

Bus routes, frequencies, and hours of service should reflect the types of running ways, locations of major activities in the corridor, market opportunities, and the resources that are available.

#### 8-2.1. Service Types and Span

BRT service opportunities and operating hours (service span) for each type of service on various running ways are the following (see also Table 8-1):

- Along arterial roadways, where passing opportunities are limited, a basic all-stop BRT service should be provided (e.g., as in Vancouver). This service may be augmented by conventional local bus routes (e.g., as in Los Angeles).

**TABLE 8-1 Service types and span**

PRINCIPAL RUNNING WAY	SERVICE PATTERN	SERVICE		
		WEEKDAYS	SATURDAY	SUNDAY
ARTERIAL STREETS MIXED TRAFFIC BUS LANES MEDIAN BUSWAYS (NO PASSING)	ALL STOP	ALL DAY	ALL DAY	ALL DAY
	CONNECTING BUS ROUTES	ALL DAY	ALL DAY	ALL DAY
FREEWAYS				
MIXED TRAFFIC	NON STOP WITH LOCAL DISTR.	ALL DAY	ALL DAY	—
BUS/HOV LANES	COMMUTER EXPRESS	RUSH HOURS	—	—
BUSWAYS				
	ALL STOP EXPRESS	ALL DAY DAY TIME OR RUSH HOURS <sup>1</sup>	ALL DAY —	ALL DAY —
	FEEDER SERVICE	DAY TIME ALL DAY OR NON-RUSH HOURS <sup>1</sup>		DAY TIME
	CONNECTING BUS ROUTES	ALL DAY	ALL DAY	ALL DAY

NOTES:  
 All Day—typically 18 to 24 hours  
 Daytime—typically 7 a.m. to 7 p.m.  
 Rush Hours—typically 6:30 to 9 a.m. and 4 to 6 p.m.  
<sup>1</sup> Feeder Bus Service in Off Peak and Express Service in Peak

- Along expressways, in both mixed traffic and reserved lanes, express bus service may be provided. This service may operate all day (as along Lake Shore Drive in Chicago), or it may run only in rush hours (as along Houston’s Transitway).
- Along busways with provisions for passing at stations, the basic all-stop service can be complemented by rush-hour or all-day express service. Local feeder and connecting bus routes can serve busway stations. This combination of services maintains service clarity, while also providing fast, transfer-free rides for commuters. Express stops can be designated based on the number of expected boardings, the size of the “catchment” area, and appropriate spacing between stations to maintain high average speeds. The Los Angeles Metro Rapid provides a combination of express and local services on its on-street running ways.
- The South Miami-Dade Busway operates 17 hours daily, the Ottawa Transitway System operates 22 hours daily, and the Pittsburgh busways operate 17 hours daily. Accordingly, it is suggested that BRT basic services operate at least from 6 a.m. to midnight.

Suggested hours for various types of service are as follows:

- Basic All-Stop Services—All day (typically 6 a.m. to midnight), 7 days each week.
- Express Service—Weekday rush hour on busy routes, also 7 a.m. to 7 p.m.
- Commuter Express Service—Weekday rush hours.
- Feeder Service—All day, generally 7 days each week.
- Connecting Service—All day, generally 7 days each week.

In some cases, “feeder” service can run during off-peak periods and be replaced by express service during weekday rush hours. Express service generally would be limited to weekdays.

**8-2.2. Service Frequencies**

Service frequencies for existing BRT systems vary depending on the city, ridership demands, and type of service. Some examples of service frequencies are the following:

- The backbone peak-hour service on the South Miami-Dade Busway is provided by three express routes, with 15-minute service on each.
- Ottawa’s all-stop 95 and 97 Transitway routes each operate at 4 to 5 minutes peak and 5 to 6 minutes off peak.
- Pittsburgh’s East Busway all-stop service operates at 4 to 5 minutes peak and 10 to 12 minutes off peak.

Service frequencies for each type of bus service should be tailored to market demands. Suggested guidelines for various types of BRT service are shown in Table 8-2.

BRT trunk line service should operate frequently so that printed schedules are not required. This suggests a maximum service frequency of 10 to 12 minutes for basic all-stop service and for express services during daytime hours. When two services operate on the same BRT line (e.g., limited-stop BRT and local bus operations or BRT express and all stop) it is desirable to have combined frequencies of about 5 minutes in the peak period and 6 to 7.5 minutes in the base period to minimize the need for set passenger schedules. Frequencies for connector and feeder services should reflect ridership demands, but they should not exceed 30 minutes. When service frequencies exceed 15 minutes, “check-face” headways are desirable.

Service frequencies, especially on peak-hour express routes, should be keyed to ridership levels. On these routes, target ridership levels of 30 to 50 passengers per 40-foot bus and 45 to 75 passengers per 60-foot bus should be achieved. When anticipated ridership falls below the suggested minimum levels, feeder rather than through service generally should be provided.

### 8-2.3. Route Length

Excessively long BRT routes should be avoided to ensure reliable service. Ideally, BRT routes should not be more than 2 hours of round trip travel time; 3 hours should be consid-

ered the absolute maximum. Assuming that routes are tailored for the downtown users, the “reach” from downtown would range from 10 to 20 miles. Longer routes would be possible for express service or busways and expressways.

### 8-2.4. Service Patterns

The service plan should be designed for the specific needs of each BRT environment and may include a variety of services. An important advantage of BRT is the ability to provide one-seat rides because of the relatively small service unit. This makes it possible to provide one-seat rides that minimize transfers and can attract choice riders. However, this point-to-point service must be balanced against the need for high-frequency, easy-to-understand service throughout the day.

When BRT operates on its own rights-of-way, the service pattern that works best features all-stop service at all times of day complemented by an “overlay” of integrated express services for specific markets during peak periods. This service pattern is found in Miami, Ottawa, and Pittsburgh. During off-peak periods, the integrated overlay routes operate as feeders to BRT stations. Good connecting schedules and communication facilities are essential, especially where these feeders have long headways.

As ridership increases, it may be necessary to increase trunk line service frequency by possibly converting some overlay services to feeders (or shuttles). Transfers should take place at stations that offer amenities and are designed to minimize walking distances and level changes.

BRT routes should serve major generators such as employment, shopping, medical, and educational centers as directly as possible. Routes should not be more than 20% longer in distance than comparable trips by automobile. They should minimize overall trip times and delays by avoiding congested roadways, minimizing turning movements in congested areas, and providing a sufficient number of stops in downtown areas.

**TABLE 8-2 Typical service frequencies**

SERVICE TYPE <sup>1</sup>	RUSH HOURS	FREQUENCY (MIN) <sup>1</sup>		
		MIDDAY	EVENING	SAT-SUN
ALL-STOP (BASE SERVICE)	5–8	8–12	12–15	12–15
EXPRESS	8–12	10–15 <sup>2</sup>	—	—
FEEDER	5–15 <sup>2</sup>	10–20	10–30	10–30
COMMUTER EXPRESS	10–20	—	—	—
CONNECTING BUS ROUTES	5–15	5–20	10–30	10–30

<sup>1</sup> Per Route

<sup>2</sup> When Operated



8-2.4.1. *Number of Routes*

An important advantage of BRT is its ability to provide point-to-point one-seat rides because of the relatively small size of the basic service unit as compared with rail transit systems. Transfers are generally minimized to attract choice riders. This operating flexibility is apparent from the number of services provided on existing busways. Some examples are the following:

- The South Miami-Dade Busway operates three express routes (one operates all day) and two all-stop routes.
- The Ottawa Transitway System Routes 95 and 97 provide 22-hour all-stop service. Some 64 other routes provide peak-period express service.
- Pittsburgh’s South Busway provides 6 express and 10 all-stop routes. The East Busway provides 36 routes; one of these is the backbone all-stop service. The West Busway has 14 routes.

Providing point-to-point service must be balanced against the need for easy-to-understand, high-frequency service throughout the day. Service clarity is essential.

It is generally better to operate fewer services at shorter headways than many services at longer headways. Thus, the number of services should be kept to a minimum. The number of individual services operated should be governed by the berths available at locations where all buses must stop. At these locations, two to three individual services (routes) per berth or less should be average. This translates into six to nine BRT services for three-berth stations. Additional services can operate when central area distribution is provided over several streets.

Generally, there should not be more than two branches per basic trunk line service (route). This is necessary for passenger clarity and the provision of reasonable frequency on each branch. Overlay services would be an additional provision.

The maximum number of buses operating during peak hours should be governed by the following considerations: (1) meeting ridership demand, (2) minimizing bus congestion, (3) maintaining service clarity, (4) controlling operating costs, and (5) working within operational constraints. Meeting these demands might require operating fewer buses than

is physically possible. Curitiba, for example, provides peak service on 90-second headways for its median busway all-stop service, whereas direct express buses operate on parallel streets. Headway-based schedules work well when buses operate at close intervals.

8-2.4.2. *Through Service*

Through routing should be encouraged where conditions permit—at least for basic BRT services. The through routes can serve more areas without requiring transfers, improve bus travel times, and reduce bus turns in the city center. BRT route segments that are connected should be balanced in terms of service frequencies, route lengths, and running times. The Ottawa and Pittsburgh transitways provide some through service. Some peak-hour express service might have to turn back in the city center. These routes could turn around on streets other than the main BRT route. This may be desirable to better serve passengers and to reduce delays at busy BRT stops.

8-2.4.3. *Extent of Running Ways*

BRT service typically operates on a variety of running ways. It can extend beyond the limits of dedicated guideways where reliable, high-speed operations can be sustained. Outlying sections of BRT lines and, in some cases, CBD distribution, can use existing roads and streets. These streets, which can include bus lanes, should be suitably modified through graphics, signage, and pavement markings to improve BRT efficiency, effectiveness, and identity. In Ottawa, about half of the Transitway routes actually operate on the Transitway itself. In Pittsburgh, more than half of the East Busway riders come from beyond the busway limits. As a general guideline, 40 to 50% of BRT route miles should be provided along busways or in reserved freeway lanes.

8-2.5. **Service Design Concepts**

Examples of service patterns are given in Figures 8-1 through 8-6. Each figure is discussed below:

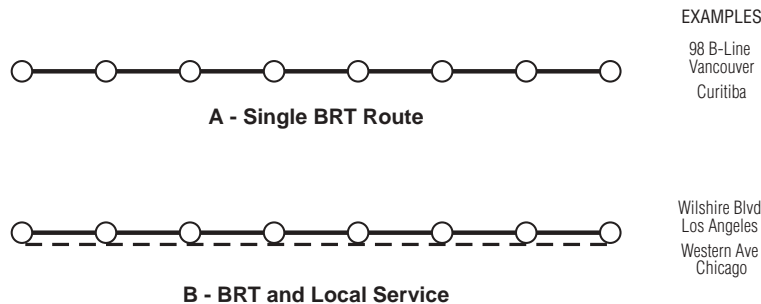


Figure 8-1. *Examples of BRT service patterns along an arterial street.*

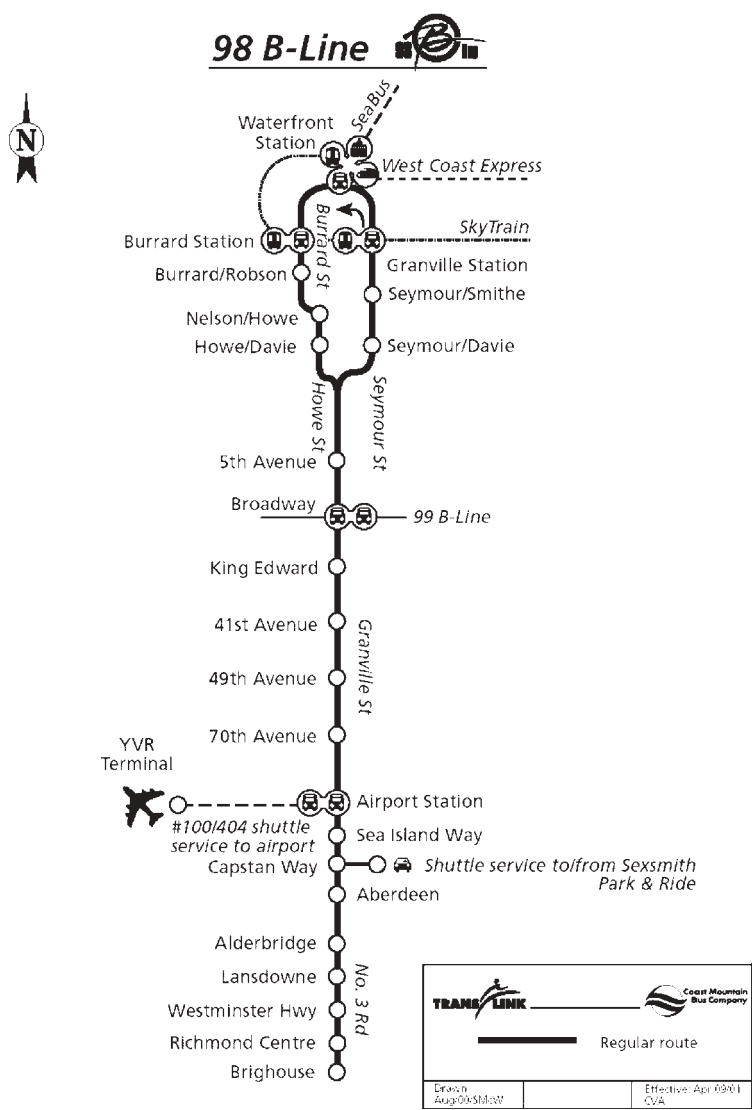


Figure 8-2. Service pattern for Vancouver's #98 B-line.

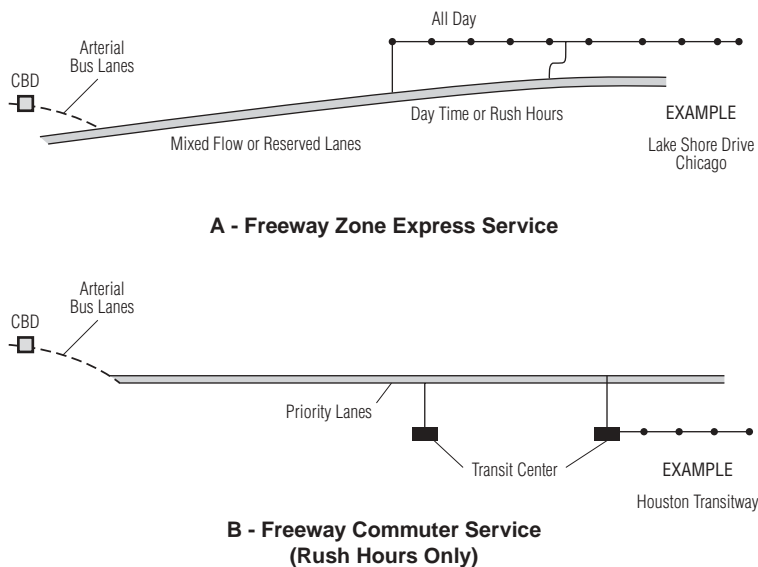


Figure 8-3. Freeway "zone express" service.



Figure 8-4. All-stop service and express BRT service overlay.

- Figure 8-1 shows typical all-stop BRT service along an arterial street. It may be the only service along the street (e.g., Vancouver’s #98 B-line), or it may be complemented by conventional service (e.g., Wilshire Boulevard in Los Angeles).
- Figure 8-2 shows the service pattern for Vancouver’s #98 B-line that operates largely in a shared running way.
- Figure 8-3 gives an example of freeway “zone express” service such as the service operated in mixed traffic along North and South Lake Shore Drive in Chicago. It also shows a freeway commuter service such as that operated in reversible HOV lanes along Houston’s freeways.
- Figure 8-4 shows that all-stop and express BRT service can be provided along busways. This service pattern is found in Brisbane, Miami, Ottawa, and Pittsburgh.
- Figure 8-5 gives an example of an integrated line-haul and neighborhood collection service.
- Figure 8-6 shows the all-stop and express service patterns along Brisbane’s South East Busway. This system is unique in that service is provided to two separate terminals in the city center.

**8-2.6. Speed Considerations**

BRT operating speeds are influenced by running way design, station spacing, station dwell times, and street traffic and bus-bus interference. Station spacing of 1/2 mile to

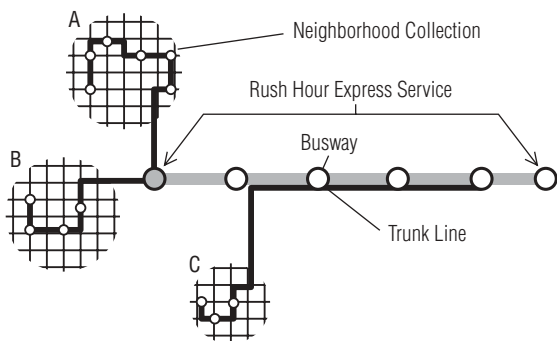


Figure 8-5. Integrated line-haul and neighborhood collection service.

1 mile along grade-separated busway stations results in a 22- to 25-mile-per-hour operating speed; however, when the spacing is increased to 2 miles, the speed increases to 40 to 44 miles per hour, as shown in Table 8-3.

Figure 8-7 shows how arterial street bus speeds (stop-and-go operations) relate to stop frequency and dwell times. At two stops per mile, speeds approximate 20 miles per hour for a 20-second stop and 15 miles per hour for a 30-second stop. When there are four stops per mile, the speeds are about 13 miles per hour for a 20-second dwell and 10 miles per hour for a 30-second dwell.

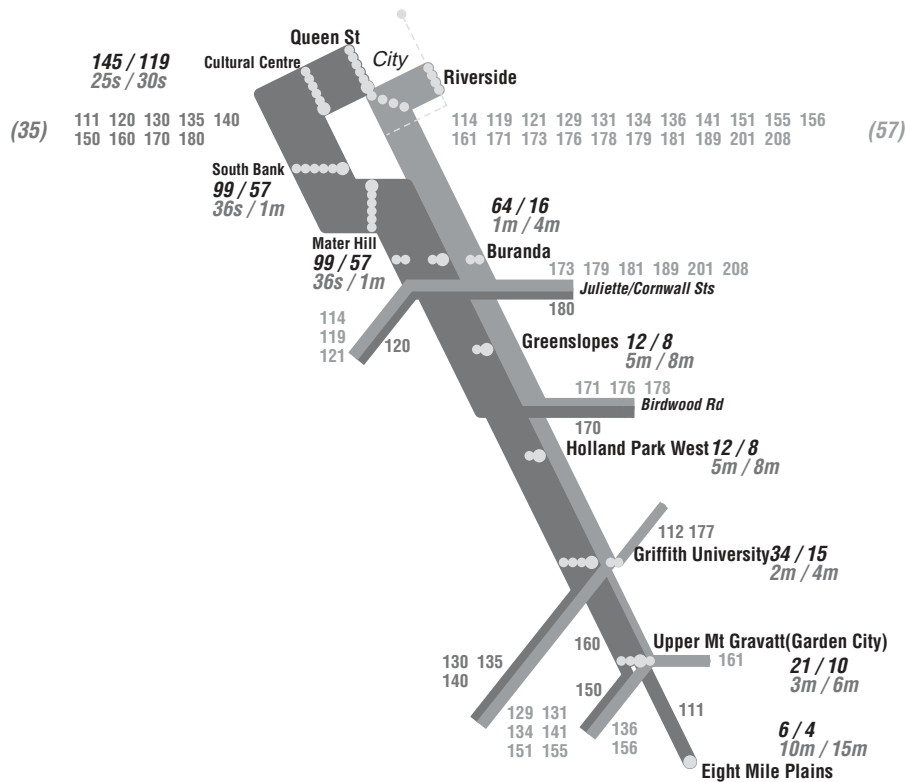
The effects of various arterial running ways, stop spacing, and dwell times on BRT speeds are shown in Table 8-4. This table provides a basis for estimating bus speeds and comparing bus speeds when there are changes in station spacing, dwell times, and traffic conditions. Part A of this table shows how travel time rates (minutes per mile) increase as station frequency and dwell times increase. Part B of the table lists further adjustments related to location and type of running way and traffic signal controls. The values for “bus lane with no right turns” should be used for median arterial busways.

As a general rule, the widest practical station spacing should be used to achieve high operating speeds. The exception is the CBD, in which closer spacing is desirable to avoid excessive dwell times. Another factor influencing bus speeds is the congestion resulting from buses interfering with each other. The values shown in Table 8-5 can be used to adjust estimates of bus speeds obtained using Table 8-4 downwards to account for bus-bus interference. Thus, if a bus station’s capacity is 100 buses per hour, and the actual bus volume is 90, bus speeds would be 69% of bus speeds in stations with light volumes.

From a BRT perspective, it is desirable to operate bus routes at 80% or less of the capacity of the system to keep bus bunching to a minimum. Curitiba, for example, runs 40 buses per hour on its arterial median busways to ensure good schedule reliability and avoid bus bunching.

**8-3. FARE COLLECTION**

BRT fare policies are important complements to the operating plan. They entail two basic aspects: the fare structure and how fares are collected.



NOTES:  
Brisbane Transport  
stopping buses only

Figure 8-6. Brisbane South East Busway, all-stop and express service patterns.

**8-3.1. Fare Structure**

BRT fares should be integrated with fares for the rest of the bus system, but BRT fares do not necessarily have to be the same. The fare structure should be kept as simple as possible.

*8-3.1.1. Same Fare*

BRT fares can be the same as for other bus services. The unified fare structure is easy for riders to understand and facil-

itates transfers between connection (or feeder) buses and trunk line BRT service.

*8-3.1.2. Premium Fare*

A surcharge could be established for BRT service, especially where it is highly differentiated from other services. The rationale is that a premium service warrants a premium charge and that premium service has higher costs than conventional service. Premium fares are commonly charged for express bus service in several cities (e.g., New York City and Houston) and may be appropriate when the BRT operates on grade-separated busways. These can be “flat” fares or zone fares in which long distance riders pay higher fares. Zone-based or distance-based fares, however, may complicate the fare collection process and result in longer dwell times at stations.

**TABLE 8-3 Busway and freeway bus lane speeds as a function of station spacing**

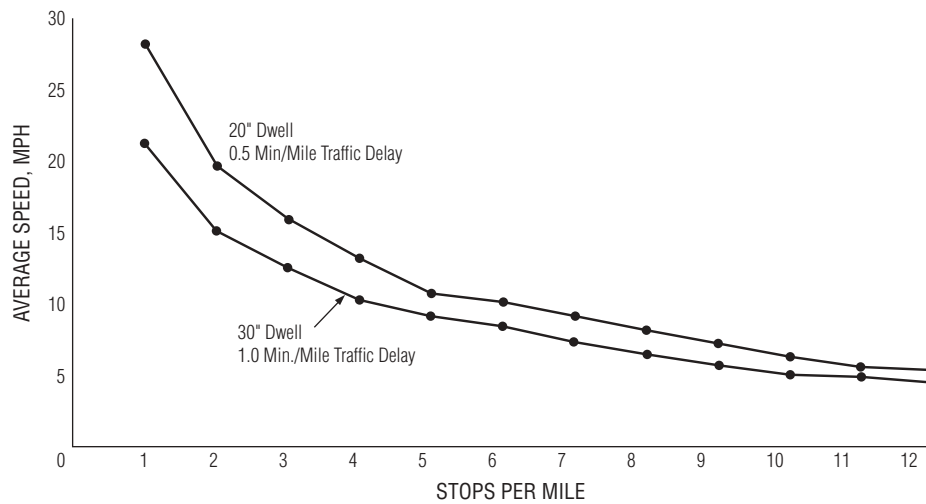
STATION SPACING (MILES)	STOPS PER MILE	SPEEDS (MPH)	
		20-SECOND DWELL	30-SECOND DWELL
0.25	4.0	18	16
0.50	2.0	25	22
1.00	1.0	34	31
1.50	0.7	42	38
2.00	0.5	44	40

SOURCES: Kittleson Associates, Inc., 2002 (Exhibit 4-47); *Transportation Planning Handbook*, 1992 (Figure 5-10).

**8-3.2. Fare Collection Options**

Existing BRT fare collection practices vary widely throughout the world. Some examples are the following:

- Some South American cities (Bogotá, Curitiba, and Quito) use metro-like fare gates or barriers in conjunction with high-platform (level) boarding of buses (see Photo 8-A).



(Source: St. Jacques and Levinson, 2000)

Figure 8-7. Relationship between arterial street bus speeds, stop frequency, and dwell times.

TABLE 8-4 Peak-hour bus travel rates for various stop spacings, dwell times, and operating environments

A. Base Travel Time Rates/Minutes Per Mile									
Average Dwell Time	Stops Per Mile								
Per Stop (sec.)	2	4	5	6	7	8	9	10	12
10	2.40	3.27	3.77	4.30	4.88	5.53	6.23	7.00	8.75
20	2.73	3.93	4.60	5.30	6.04	6.87	7.73	8.67	10.75
30	3.07	4.60	5.43	6.30	7.20	8.20	9.21	10.33	12.75
40	3.40	5.27	6.26	7.30	8.35	9.53	10.71	12.00	14.75
50	3.74	5.92	7.08	8.30	9.52	10.88	12.21	13.67	16.75
60	4.07	6.58	7.90	9.30	10.67	12.21	13.70	15.33	18.75
B. Additional Travel Time Losses/Minutes Per Mile									
CENTRAL BUSINESS DISTRICT									
	Bus Lane With No Right Turns	Bus Lane With Right Turn Delay		Bus Lanes Blocked by Traffic		Mixed Traffic Flow			
Typical	1.2	2.0		2.5-3.0		3.0			
Signal Set For Buses	0.6	1.4		N/A		N/A			
Signals More Frequent Than Bus Stops	1.7-2.2	2.5-3.0		3.0-4.0		3.5-4.0			
ARTERIAL ROADS OUTSIDE OF CBD									
	Bus Lane			Mixed Traffic					
Typical	0.7			1.2					
Range	0.5-1.0			0.8-1.6					

NOTE:  
 Add values from Part A and Part B to obtain suggested estimate of total bus travel time. Convert total travel time rate to estimated average speed by dividing into 60 to obtain mph. Interpolation between shown values of dwell time is done on a straight-line basis.  
 SOURCE: Kittleson Associates, Inc., 2002.

**TABLE 8-5** Speed reduction factors resulting from bus-bus interference

BUS BERTH VOLUME-TO-CAPACITY RATIO	INDEX (SPEED REDUCTION FACTOR)
< 0.5	1.00
0.5	0.97
0.6	0.94
0.7	0.89
0.8	0.81
0.9	0.69
1.0	0.52
1.1	0.35

SOURCE: St. Jacques and Levinson, 1997.

- European systems generally use proof of payment, thereby avoiding fare collection on board buses (see Photo 8-B).
- Most North American BRT systems have on-board fare collection. A significant exception is Boston's Silver Line (under construction), in which subway stations will have prepayment of fares.

Fare collection is generally the weakest element of BRT systems in the United States and Canada. Efforts to address this problem have been inhibited by service patterns and low passenger boardings at many stations. Nevertheless, fare collection practices need improvement for most systems. The basic objectives are to maximize passenger convenience and minimize dwell times at stops. Multidoor boarding of buses



Photo 8-A. Fare gates in Curitiba, Brazil.



Photo 8-B. Proof-of-payment system in Trans-Val-de-Marne, France.

should be achieved by off-board (preferred) or on-board multi-door payment. Fast boarding is essential at major boarding points, especially during peak periods.

#### 8-3.2.1. Off-Board Collection

Off-board (off-vehicle) collection is customer friendly and allows the use of all bus doors for boarding, thereby reducing passenger service times, station dwell times, bus travel times, and operating costs. It may be achieved in several ways.

**Prepayment.** Passengers can pay fares and then pass through turnstiles or barrier gates to board buses, thereby eliminating on-board payment. Passengers can use all doors, keeping dwell times to a minimum. This method of fare collection is clearly applicable at major stations along busways. However, there are several disadvantages to this method of payment: (1) sidewalk space for fare gates may be insufficient at curbside boarding locations, (2) installation costs may be high, and (3) heavy passenger boardings (at least 75 to 100 boardings per day) would be needed to support staffed stations. Thus, prepayment may be impractical at many BRT stations with low passenger boardings.

**Auxiliary Platform Personnel.** Fares can be manually collected at center and rear doors of buses at busy stations during the periods of peak boardings. This practice eliminates the need for major capital investment, but it may increase operating costs.

**Vending Machines and Proof of Payment.** Boarding passengers can use fare or ticket vending machines located on station platforms to purchase tickets and then board buses through all doors. In Europe, the vending machines are located near each door. The validated receipts constitute proof of payment. It is desirable to provide at least two ticket validating machines wherever fares are collected off the vehicles to give backup when one machine is out of service. The equipment needs power, communication lines, and shelter.

**Proof of Payment.** This may be required where ticket-vending machines, passes, or smart cards are used. This system requires passengers to show their validated ticket or passes on vehicles when requested to do so. Fare inspectors randomly verify fare payment and give appropriate penalties to violators. Ticket vending machines and proof of payment have been used successfully on new light rail lines opened in North America since the 1980s. The advantage of reduced dwell times at stops may outweigh the additional inspection costs along BRT lines.

**Free-Fare Zones.** Free-fare zones can be used in downtown areas with high concentrations of passenger boardings. However, although their application is desirable for short intra-CBD trips, free-fare zones can result in substantial revenue

loss from trunk line BRT passengers and high dwell times, which could result in delay to customers.

8-3.2.2. *On-Board Collection*

Collecting fares on vehicles works well at low-volume stations and during off-peak hours and eliminates the need for special fare collection provisions on sidewalks and at stations.

**Conventional On-Board Collection.** Conventional on-board fare collection limits passenger entry to a single door. It results in long passenger service times, especially when fare structures are complex. It can be improved by using double channel doors; patrons with passes (or fare cards) can use one door and cash patrons can use another.

**Pay Enter Inbound, Pay Leave Outbound.** This method of fare collection reduces bus dwell times at stations in the city center. It has been successfully used on Pittsburgh’s busway system for several decades.

**Passes.** The use of weekly or monthly transit passes can effectively reduce dwell times. Passengers using passes can board all doors of three-door articulated buses. Some random inspection of riders is needed to deal with violators. This practice is used along Ottawa’s 95 and 97 BRT lines. Median station dwell times along Ottawa’s 95 and 97 BRT lines are reported to be less than 30 seconds, whereas dwell times of 1 minute or more are reported in Portland, Oregon, and New York City (as shown in Table 8-6).

**TABLE 8-6 P.M. peak-period bus performance in selected cities**

	Fifth Ave.	Sixth Ave.	Second Ave.	Albert St.	Commerce St.	Market St.
	Portland	Portland	New York City	Ottawa	San Antonio	San Antonio
Type of Lane	Dual Bus Lane	Dual Bus Lane	Curb Bus Lane	Curb Bus Lane	Curb Bus Lane	Curb Bus Lane
Stops per Mile	10	10	8	5	10	6
Hourly Bus Flow Rates by 15-Min Interval						
Range	76–164	88–112	16–52	100–164	56–100	80–108
Median	136	96	26	132	80	96
Dwell Times by 15-Min Interval (sec)						
Range	10–65	8–55	19–78	15–27	10–32	23–30
Median	29	32	29	18	22	26
Mean Coefficient of Variation	0.52	0.54	0.57	0.59	0.81	0.57
Bus Speeds Compiled by 15-min intervals (mph)						
Range in Mean Speed	2.6–4.7	3.7–4.2	4.4–8.0	9.1–12.8	4.2–6.3	6.0–7.0
Range in Standard Deviation (mph)	0.5–1.5	0.9–1.5	0.2–2.7	1.3–3.6	0.6–1.5	1.0–2.3

SOURCE: St. Jacques and Levinson, 2000.



Photo 8-C. ITS smart card technology, Washington Metropolitan Area Transit Authority.

**Smart Cards.** ITS smart card technology, as described in Chapter 7, can allow simultaneous on-board fare payment and multiple door boarding without increasing revenue loss. Passengers quickly use the cards as they board buses, as shown in Photo 8-C. Smart cards work in a closed system through radio frequency transmission. They work without batteries and are contactless, and they contain read-only units, unique serial numbers, proximity cards, and stored value features.

### 8-3.3. Design Considerations

The fare collection equipment provided should be sufficient to minimize waiting time, transaction time, and queuing. Factors include the following:

- Ridership at each stop, on and off, all day and during peak periods;
- Surges when vehicles arrive or unforeseen incidents occur;
- Conflicts between arriving and departing passengers;
- Fare collection policies;
- Physical space required and available;
- Utility access; and
- Potential for vandalism.

### 8-3.3.1. Station Dwell Time Implications

The effects of various fare payment methods on passenger service times are given in Table 8-7 for a single door channel. Prepayment results in a service time of 2.5 seconds per passenger (per door channel) as compared to 3.5 seconds for a single ticket, token, or smart card and 4 seconds or more for exact change, swipe cards, or dip cards. Prepayment and smart cards would enable passengers to board through several doors, further reducing service times. Illustrative comparisons for two boarding streams are as follows:

Prepayment	1.8 seconds
Smart Cards	2.4 seconds

Therefore, for 10 boarding passengers per bus, the station dwell times would be as follows (assuming unequal use of doors):

Single Door Channel		Two Door Channels
Exact Fare	40 seconds	N.A.
Smart Card	35 seconds	24 seconds
Prepayment	25 seconds	18 seconds

## 8-4. MARKETING BRT SERVICE

Marketing BRT service has two basic objectives: to emphasize the unique features of BRT and to create a unified system image and identity by coordinating marketing with the overall BRT theme used throughout the system. Like any form of public transport marketing, BRT marketing activities should be people-centered and focus on product, promotion, and price. Examples of marketing activities and elements are shown in Figure 8-8 and Figure 8-9. Major marketing elements also can be viewed in terms of image, information, and promotion.

### 8-4.1. Image

Marketing for BRT should establish the general image associated with BRT and emphasize its unique attributes of speed,

**TABLE 8-7 Bus passenger service times for various fare collection methods**

Situation	Passenger Service Time (seconds/passenger)	
	Observed Range	Suggested Default
<b>BOARDING</b>		
Prepayment*	2.25–2.75	2.5
Single ticket or token	3.4–3.6	3.5
Smart card	3.0–3.7	3.5
Exact change	3.6–4.3	4.0
Swipe or dip card	4.2	4.2
<b>ALIGHTING</b>		
Front door	2.6–3.7	3.3
Rear door	1.4–2.7	2.1

**NOTES:**

Add 0.5 seconds/passenger to boarding times when standees are present.

Subtract 0.5 seconds/passenger from boarding times and 1.0 seconds/passenger from front-door alighting times on low-floor buses.

\* includes no fare, bus pass, free transfer, and pay on exit.



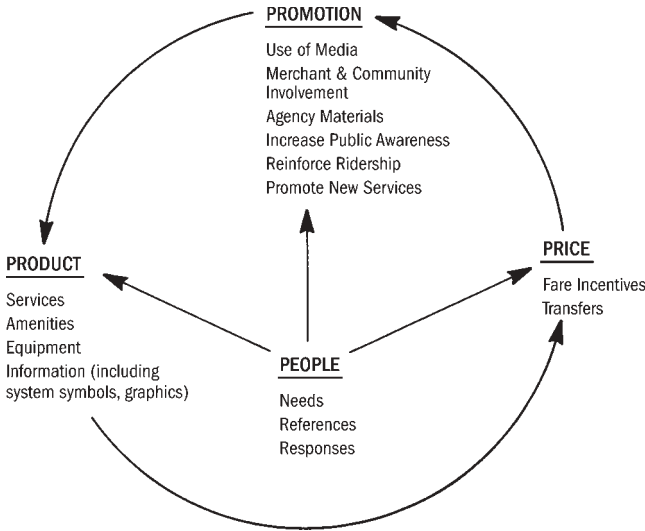


Figure 8-8. Examples of marketing activities.

reliability, and identity. A special brand identity should be established for BRT. Examples of systems that have developed a distinct BRT identity include Metro Rapid in Los Angeles; CityExpress! in Honolulu, and the Silver Line in Boston. Distinctive logos, color combinations, and other graphics standards should be established for use on vehicles, at stations, and on printed materials.

**8-4.2. Passenger Information**

Passenger information is the backbone of the BRT marketing effort. Route and service identification and vehicle design and graphics are two important aspects of passenger information.

*8-4.2.1. Route/Service Identification*

BRT routes should be clearly identified by name and number, and other services should also be clearly designated. Sym-

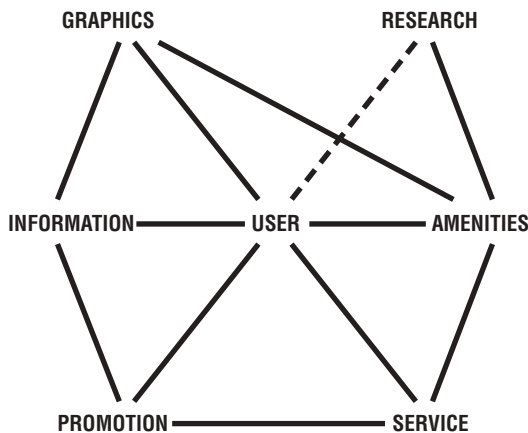


Figure 8-9. Relationship of major marketing elements.

bols such as “RAPID” or “R” could be placed on BRT vehicle side and destination signs. A supplementary designation such as “Limited,” “All-Stop,” or “Express,” (“X”) could be added when several BRT services are provided. When there is only one service, such as along an arterial roadway, the symbol, “X,” or “Express” could be used.

*8-4.2.2. Vehicle Design and Graphics*

Vehicles should be distinctively marked, colored, and designed to distinguish the service from conventional bus service. The vehicle color also should be used on system timetables, maps, brochures, and information signs. Metro Rapid in Los Angeles, for example, uses red colored buses (reminiscent of Pacific Electric Railway red cars); Bogotá, Curitiba, and Quito use distinctive vehicles; and the Rouen system provides a special image with its distinctive Irisbus Civis vehicles.

**8-4.3. On-Board Information**

Route information should be readable on buses. A strip route map—similar to that used on rail and light rail lines—should be placed within the vehicle, showing stations served. Figure 8-10 shows the Chicago Transit Authority card for the Western 49 Express operations.

Stop announcements can be made automatically when combined with an AVL system. Announcements for customers without hearing impairments and customers with visual impairments must be accompanied by visual displays for the hearing impaired.

*8-4.3.1. Wayside Information*

As described in Chapter 7, automated “next bus” information can be provided at stations, on platforms, and within station buildings in addition to information displays. Information that is available at information displays should clearly embody the BRT logo or signature and include BRT (and system) route maps and schedules, vicinity maps showing pertinent features and attractions, hours of service operation, and key telephone numbers to call for further information. Traditional telephone information centers and interactive voice-responsive systems may be appropriate at major stations.

*8-4.3.2. Off-Site Information*

BRT information kiosks containing timetable racks and other pertinent information can be provided at key passenger attractions along each BRT route and, in some cases, as window (or store front) displays.

*8-4.3.3. Internet*

The Internet has emerged as a major communications and marketing media. In this context, it can serve as a means of

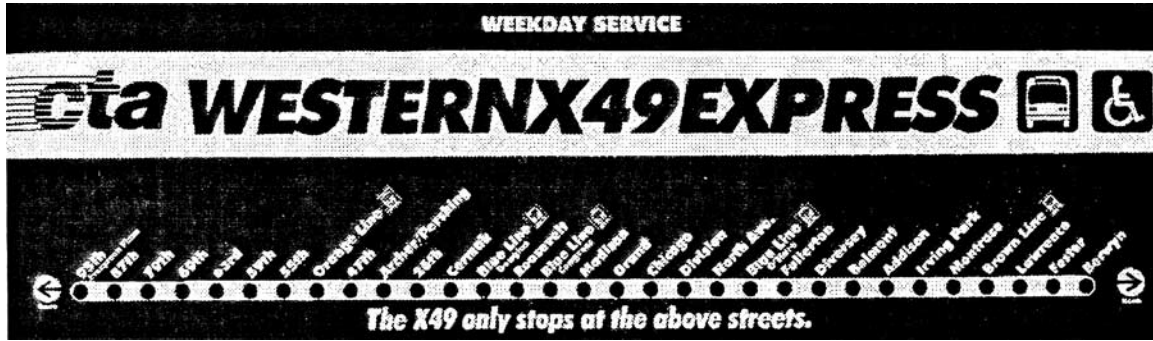


Figure 8-10. Example of simple display of route information.

disseminating information about BRT services and how riders can use these services to reach major destinations. This information should be clearly incorporated in transit agencies' websites.

8-4.3.4. Maps, Schedules, and Brochures

BRT passenger information should clearly convey the BRT color and logo themes. It should also display thematic messages such as "Ride the Rapid" that emphasize the unique features of the BRT services.

**System Maps.** System maps should display BRT routes and stations in the same way that rail transit lines are dis-

played. Figure 8-11 gives an example of a system bus route map with the BRT line superimposed. Each BRT station is clearly identified. Connecting and other local bus routes are noted by number at their terminal points and along the route as needed.

The front side of the map should include the cover face of the map when folded, be color coded as appropriate, and give general information. Depending on the system, route information and a schematic BRT route map should be provided.

The system map should show the following information for each route:

- Route number;
- Route name;
- Route terminal points;

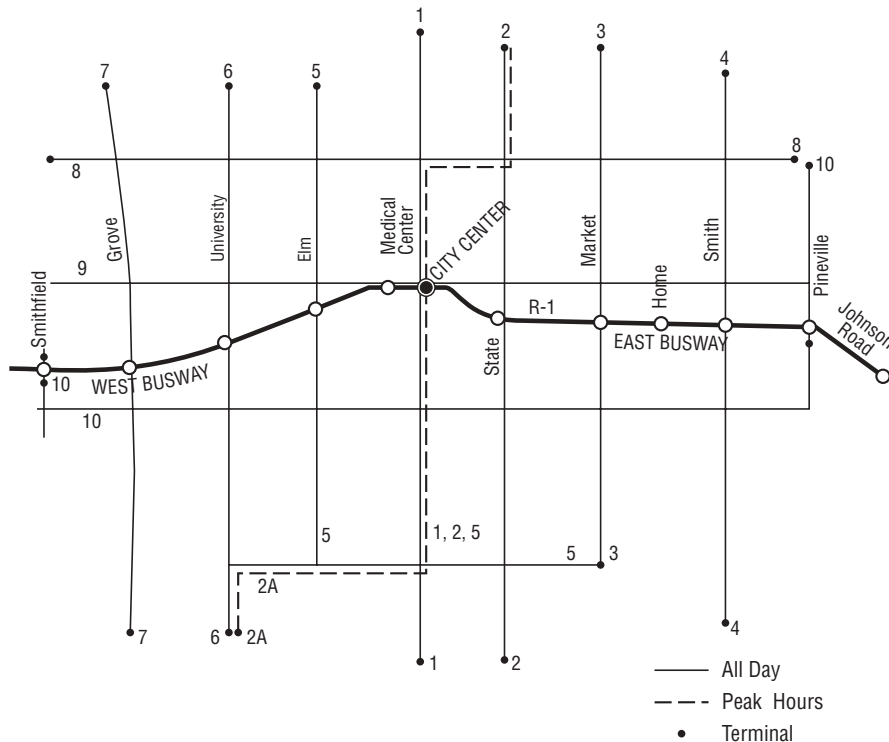


Figure 8-11. Example of a system bus route map with the BRT line.

- Time of the first and last bus on weekdays, Saturdays, and Sundays;
- Service frequency on weekdays, Saturdays and Sundays, and during the a.m. peak period, the midday base period, the p.m. peak period, the evening period, and overnight (when operated);
- Relevant fare information;
- Telephone numbers and address of the operating agency; and
- Principal points of interest, keyed to the map.

A portion of the map could be devoted to advertising if desired.

**Passenger Schedules.** Schedules should be 6 inches by 4 inches or 8 inches by 4 inches when folded. The cover should contain the BRT route name and number, a schematic map (if possible), and a panel that displays the BRT “theme.” A schedule embodying these features is shown in Figure 8-12. Colors should reinforce the basic BRT vehicle color schemes. Figure 8-13 provides examples of the busway schedules used in Pittsburgh. Schedule covers prominently display the type of busway operation, the route numbers, and the stops made.

**Informational Brochures.** Informational brochures should advise passengers when service is introduced or changed, as well as furnish general information regarding the features of BRT. Figure 8-14 shows the brochures used in Vancouver and Brisbane. Figure 8-15 gives examples of possible

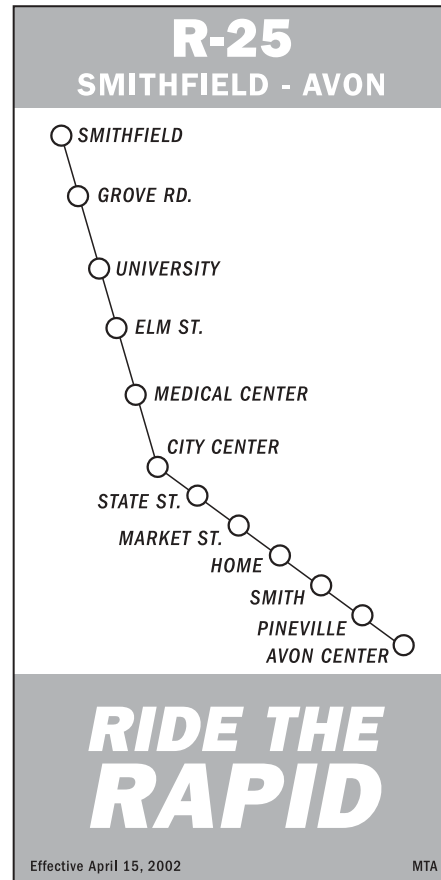


Figure 8-12. Illustrative BRT schedule.

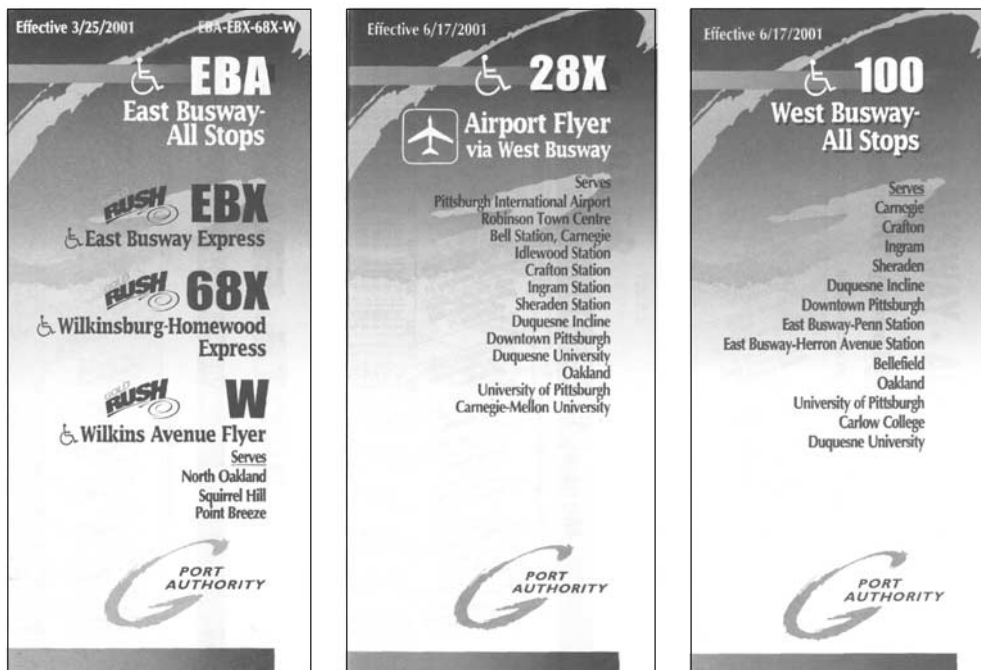


Figure 8-13. Marketing materials for busways in Pittsburgh.

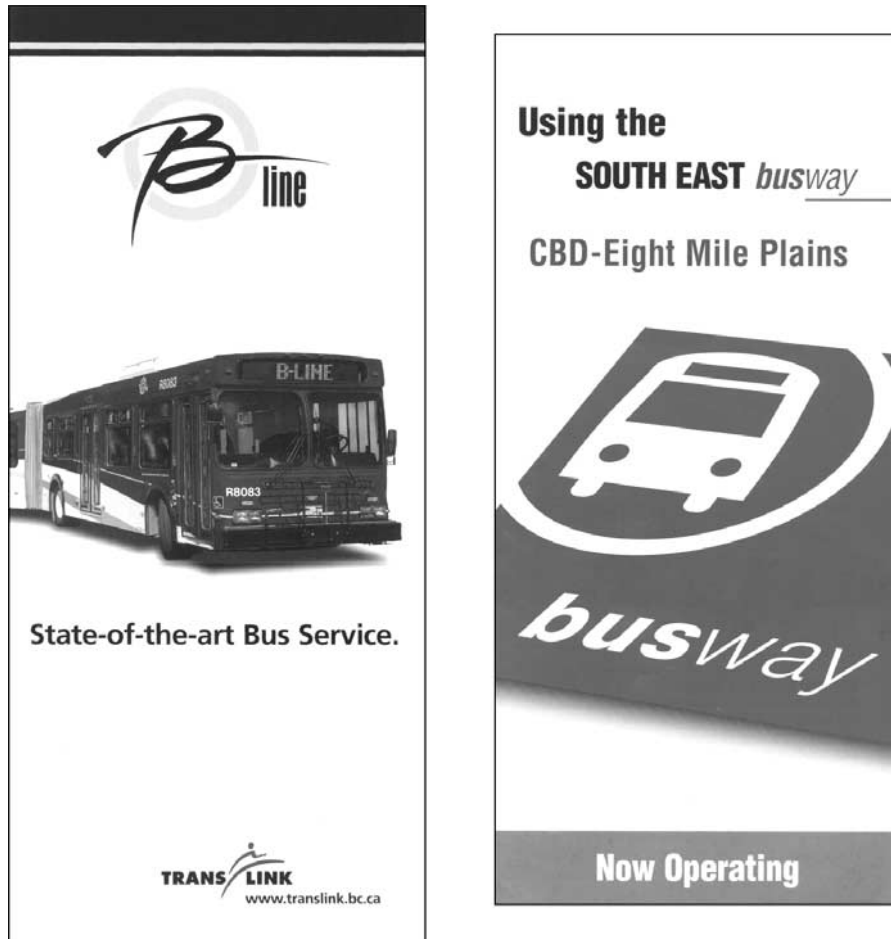


Figure 8-14. Marketing materials for busways in Vancouver and Brisbane.



Figure 8-15. Examples of BRT marketing themes.

promotional brochures keyed to a common theme, such as “Ride the Rapid.” Newsletters, such as the “Rapid Reader News,” can also be used to advantage.

#### 8-4.4. Promotional Programs

Promotional programs contain three related aspects: (1) advertising and public information, (2) service innovations, and (3) pricing incentives. These programs should be keyed to different market segments of existing and potential BRT riders. The goals of these programs are to answer questions about BRT services and to persuade potential customers to use the service.

##### 8-4.4.1. Paid Advertising

Methods of marketing BRT include TV and radio advertising featuring BRT service, news media advertisements, and the use of display advertising such as outdoor advertising posters.

#### 8-4.4.2. *Joint Promotions*

Joint promotions with noncompeting businesses should be encouraged. Examples include fast-food outlet distribution of complimentary ride coupons and radio mentions of BRT in relation to specific products.

#### 8-4.4.3. *Service Innovations*

“Shoppers Special” BRT service and special service to sporting events or conventions are among the service innovations that should be considered in marketing BRT.

#### 8-4.4.4. *Fare Incentives*

A variety of fare pricing incentives can be part of BRT marketing activities. Free rides should be provided on operating days when BRT service is initiated; Provisions of such service resulted in high first-day ridership when Brisbane’s

South East Busway was placed in service. Discounted weekly and monthly passes, joint BRT fares and parking fees, and free off-peak rides for senior citizens during pre-Christmas shopping periods are among fare incentive policies that should be considered.

### 8-5. CHAPTER 8 REFERENCES

- Kittelson and Associates, Inc. “Update of the First Edition, *Transit Capacity and Quality of Service Manual*” (TCRP Project A-15A). Unpublished Draft (October 2002).
- St. Jacques, K., and H. S. Levinson. *TCRP Report 26: Operational Analysis of Bus Lanes on Arterials*. Transportation Research Board, National Research Council, Washington, DC (1997).
- St. Jacques, K. R., and H. S. Levinson. *TCRP Research Results Digest 38: Operational Analysis of Bus Lanes on Arterials: Application and Refinement*. Transportation Research Board, National Research Council, Washington, DC (2000).
- Transportation Planning Handbook* (1st ed.). Institute of Transportation Engineers, Washington, DC (1992).
-

## CHAPTER 9

# FINANCING AND IMPLEMENTING BRT SYSTEMS

Implementing BRT calls for a clear understanding of its benefits and costs, the availability of funding, and the different mechanisms that can be used to finance, develop, and operate a BRT project. The planning and development process for BRT should be similar to that of other transit modes. However, because BRT systems have attributes that distinguish them from other rapid-transit modes, including flexibility in operations and incremental development, there are several unique implementation issues associated with the development of BRT systems.

In developing BRT systems, it is necessary to establish how the system will be planned, designed, built, operated, and fully integrated into the overall transport system. BRT should be developed with each stage keyed to levels of passenger demand and available resources. In addition, because BRT systems can operate on different types of running ways (e.g., dedicated busways or local streets), a number of agencies will be involved in implementing and operating the system. This creates an additional level of institutional complexity to the development of BRT projects. This chapter includes guidelines on developing and implementing BRT systems, including information on benefits and costs, funding sources, institutional arrangements, policy issues, and project delivery mechanisms.

### 9-1. GENERAL GUIDELINES

Several general guidelines for implementing BRT systems can be drawn from a review of previous experience with BRT systems worldwide. These guidelines include the following:

1. BRT systems should be integrated with other transit services in terms of route structure, services coordination, and fares.
2. Overall system benefits—as measured by travel time savings, operating cost savings, and land development benefits—tend to increase in correlation with operating speeds. High speeds, however, usually result from operating on dedicated busways, which have higher development costs.
3. When travel time savings and ridership are substantial and market conditions are right, BRT can generate substantial land development benefits.
4. BRT systems can be financed through combinations of federal, state, and local government funding, as well as financed by the private sector.
5. Value capture, benefit assuming, and other public-private partnerships can complement public funding in special circumstances, particularly in proximity to major transit stations.
6. Transit agencies, city transportation departments, and, in some cases, state departments of transportation must work together in planning, designing, and maintaining BRT systems. Close cooperation and coordination is essential.
7. Most BRT systems have been developed under traditional design-build arrangements. However, for major integrated projects, alternative project delivery strategies, such as design-build-operate-maintain arrangements, may also be appropriate (as demonstrated by international experience with rail systems).
8. BRT is well suited for incremental development because of its flexibility. Each stage should contain a well-packaged series of BRT elements and should produce tangible benefits. Early action is essential to maintaining community interest and support.
9. BRT systems, like any rapid-transit system, should be designed to be as cost-effective as possible. However, planners should not “cut corners” by eliminating key system elements and their integration because it will still be possible to attain minimal functionality of the bus system. Cutting corners will greatly reduce the potential benefits that can be achieved by a fully integrated BRT system.
10. BRT busways can be designed for possible future conversion to rail as needs arise or ridership warrants.
11. Parking and land use policy should be carefully designed to reinforce BRT operations.

### 9-2. BENEFITS AND COSTS

Benefits and costs should be estimated for each BRT line based on the area that is traversed, the travel time saved, and the type of construction. Existing BRT experience can be used as a guide in this effort.

**9-2.1. Benefits**

The benefits of BRT systems—largely a result of faster journey times, higher frequency, and better reliability—translate into increased ridership, lower operating costs, less fuel consumption, greater safety, and better land development benefits.

*9-2.1.1. Ridership*

Reported increases in BRT riders range from 20 to 80%, as shown in Table 9-1. The increases reflect the provision of expanded transit service, reduced travel times, system identity and branding. Collectively, they clearly demonstrate that BRT can attract and retain new and discretionary riders.

Some evidence suggests that many of the new riders of BRT were previously motorists and that improved bus service results in more frequent travel. In Houston, for example, up to 30% of the Transitway system riders did not make the trip before, and up to 72% were diverted from automobiles. In Vancouver, 20% of new B-line riders previously used automobiles, 5% represented new trips, and 75% were diverted from other bus lines.

Increases in ridership attributed to BRT have ranged as high as 100% or more over the initial application period. For example, transit ridership in Miami-Dade’s South US-1 corridor has increased from approximately 7,000 daily trips in 1996, before the South Miami-Dade Busway opened, to over 14,000 trips per day today. In Honolulu, ridership has gone from approximately 3,000 on corridor bus routes to more than 6,500 trips per day in the year since CityExpress! opened.

Implementation of the Metro Rapid bus on Los Angeles’s Wilshire, Whittier, and Ventura Boulevards has resulted in increases of 20% and 50%, respectively, in total corridor bus ridership. Over one-third of the new trips on the Metro Rapid bus services were made by travelers who did not previously use transit at all before the lines opened. In the Wilshire-Whittier corridor, over 60,000 trips per day are currently made on Metro Rapid bus, a number currently constrained by the capacity of 40-foot buses (to be replaced by articulated 60-foot buses, currently in procurement).

*9-2.1.2. Travel Time Savings*

Reported travel time savings over pre-BRT conditions are given in Table 9-2. Time savings range from 23 to 32% for city street operations and go up to 47% for operations on busways

or reserved freeway lanes. Busways on dedicated rights-of-way generally save 2 to 3 minutes per mile compared with pre-BRT conditions, including time for stops. Bus lanes on arterial streets typically save 1 to 2 minutes per mile. The time savings are greatest where the bus routes previously experienced major congestion. Pittsburgh, for example, has reported travel time savings of up to 5 minutes per mile during peak hours.

Time savings can result in economic benefits, according to the amount of time saved. Figure 9-1 shows the following:

- A small amount of time savings merely results in passenger benefits;
- As the time saved increases, it reduces fleet requirements and direct operating costs;
- A time savings of more than 5 minutes on a typical urban work trip can affect modal choice, and, under certain circumstances, it can foster land development.

MBTA estimates that the Silver Line project will result in a 3- to 5-minute travel time saving from Washington Street to downtown. In Eugene, Oregon, the Lane Transit District estimates that the BRT system will decrease travel time by 20% as compared with regular bus service in the year implementation of BRT begins.

*9-2.1.3. Operating and Environmental Benefits*

The travel time savings associated with buses operating on their own rights-of-way are also associated with beneficial effects on operating costs, safety, and environmental benefits. Table 9-3 shows the following;

- Services using Ottawa’s Transitway system require 150 fewer buses than if the Transitway system did not exist, resulting in savings of roughly \$58 million in vehicle costs and \$28 million in annual operating and maintenance costs.
- Seattle’s bus tunnel has reduced surface street bus volumes by 20%. Buses using the tunnel also had 40% fewer accidents than in mixed traffic operations.
- Bogotá’s TransMilenio Busway reduced fatalities among transit users by 93%. In addition, a 40% drop in pollutants was recorded during the first 5 months of operation.
- Curitiba uses 30% less fuel per capita for transportation than other major Brazilian cities. This has been in part due to the huge success of the BRT system.

**TABLE 9-1 Reported ridership gains**

Application	Ridership Gain	Remarks
Los Angeles	+ 30%	> 2 years, strike
Miami	+ 80%	> 4 years
Brisbane	+ 60%	> 18 months
Vancouver	+ 20%	> 1 year, strike
Boston	+ 50%	> 5 months after opening

SOURCE: Levinson et al., 2003.

**TABLE 9-2 Examples of travel time savings**

Type of Running Way	Reported Increase
Busways, Freeway Lanes	32–47%
Bus Tunnel—Seattle	33%
Arterial Street Busways / Bus Lanes	29–32%

System	Reported Increase
Bogotá	32%
Porto Alegre	29%
Los Angeles Metro Rapid Bus	23–28%

SOURCE: Levinson et al., 2003.

#### 9-2.1.4. Land Development Benefits

Reported land development benefits with full-featured BRT are similar to those experienced along rail transit lines. These benefits vary by location and also depend on the presence of supportive land use policies and favorable real estate market conditions. Table 9-4 illustrates several reported land development benefits of BRT systems.

Studies have indicated that construction of the Ottawa Transitway led to over \$675 million (U.S. dollars) in new construction around transit stations from the time of its inception to the mid-1990s. A study completed by the Port Authority of Allegheny County reported that \$302 million in new and improved development occurred at East Busway stations during a similar period. Property values within walking distance of Brisbane's South East Busway grew 20% faster than

in other areas in the corridor, an increase largely attributed to the busway construction.

#### 9-2.2. BRT Costs

BRT costs are made up of capital costs (including all costs for facility development and construction) and operations costs, which include maintenance costs.

##### 9-2.2.1. Capital Costs

BRT facility development costs reflect the location, type, and complexity of construction. Reported median costs were \$272 million per mile for bus tunnels (2 systems), \$7.5 million per mile for independent, at-grade busways (12 systems), \$6.6 million per mile for arterial median busways (5 systems), \$4.7 million per mile for guided bus operations (2 systems), and \$1 million per mile for mixed traffic and/or curb bus lanes (3 systems). The reported capital costs for several BRT projects are shown in the summary tables located in Appendix F.

BRT can achieve significant performance improvements without large capital expenditures. Although desirable, it is not necessary to construct a fully dedicated transitway over the entire distance of a busy corridor to guarantee a high level of speed, safety, and reliability for services covering its entire extent. For example, although only the first approximately 8 miles from downtown Pittsburgh westward are covered by the West Busway (or Airport Busway), West Busway BRT users in Pittsburgh enjoy an almost congestion-free ride at all times of day on the over 20-mile distance between the Pittsburgh airport and downtown Pittsburgh.

BRT running ways are also less expensive to construct from scratch (per unit length) than rail-based modes (all things

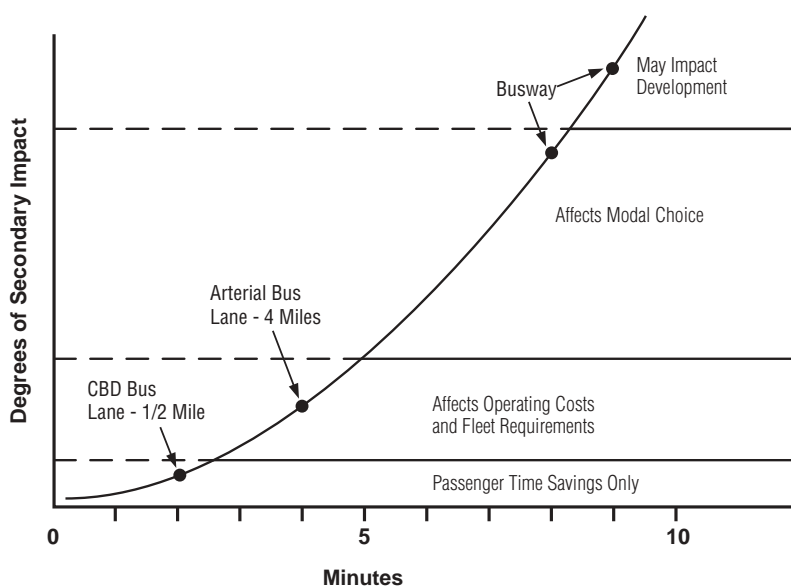


Figure 9-1. Examples of BRT impacts.



**TABLE 9-3 Reported operating benefits**

System	Benefit
Ottawa Transitway	150 fewer buses, with \$58 million (\$C) savings in vehicle costs and \$28 million (\$C) in operating costs.
Seattle Bus Tunnel	20% reductions in surface street bus volumes. 40% fewer accidents on tunnel bus routes.
Bogotá TransMilenio Median Busway	93% fewer fatalities. 40% drop in pollutants.
Curitiba Median Busway	30% less fuel consumption per capita.

SOURCE: Levinson et al., 2003.

being equal) because they are simpler. Their construction can be competitively procured from a much larger number of local firms than other forms of rapid transit. BRT also does not require elaborate, purpose-built signal or power supply systems, and implementation of BRT rarely means construction of totally new, expensive operating and maintenance yards and shops. Sophisticated, electronically guided BRT vehicles can be maintained and stored off-line where it is convenient (e.g., at an existing bus operating and maintenance facility).

BRT vehicles can be conventional, low-floor, low-noise and low-air-emissions buses. With seating and door configurations optimally suited to the nature of a given market, BRT vehicles can be painted in special livery with special graphics to provide a system identity consistent with the rest of the given line's stations, running ways, and so forth. At the other end of the spectrum, manufacturers around the world are producing special rubber-tired, steered or guided, specialized rapid-transit vehicles.

Irrespective of whether they are conventional buses or purpose-built vehicles, BRT vehicles are typically less expensive than other rapid-transit vehicles, even when the price is adjusted for capacity and service life. A variety of factors make BRT vehicles less expensive, including economies of scale, competition, and lower structural strength requirements.

*9-2.2.2. Operating Costs*

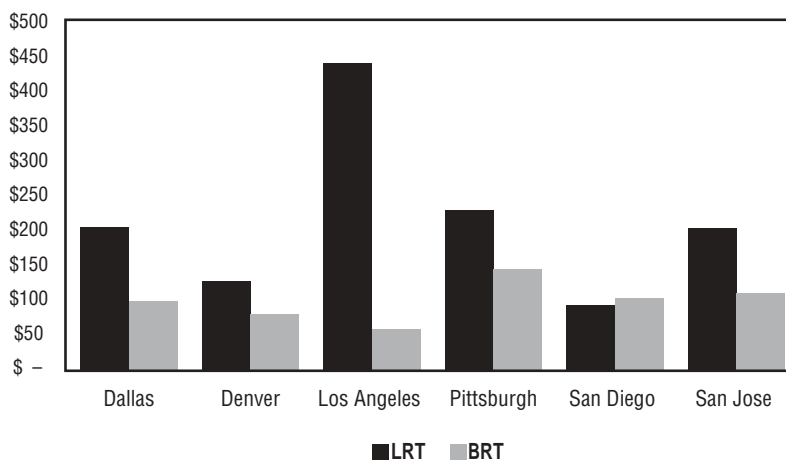
Operating costs for BRT service are influenced by wage rates and work rules, fuel costs, operating speeds, and ridership. Operating costs for Pittsburgh's East and South Busways (1989) averaged \$0.52 per passenger trip. Costs per trip for light rail lines in Buffalo, Pittsburgh, Portland, Sacramento, and San Diego averaged \$1.31; the range was from \$0.97 (San Diego) to \$1.68 (Sacramento). These comparisons suggest that BRT can cost less per passenger trip than LRT under the demand and operating conditions found in most U.S. cities. Figure 9-2 illustrates operating costs per vehicle revenue hour for several BRT systems.

Farebox cost recovery ratios depend on system speed, ridership density, fare structure, and operations wages. Ottawa has experienced a 60% farebox recovery systemwide, but actually turns a small operating profit on the two routes that operate on its Transitway system. Vancouver's #99 B-line has achieved a 96% farebox recovery as compared with 32% systemwide. Some South American cities with high ridership densities (e.g., Bogotá and Curitiba) also fully cover BRT operating costs from fares. For BRT operations in the United States and Canada, a target recovery ratio of at least 40 to 50% should be realized on BRT routes.

**TABLE 9-4 Reported land development benefits**

SYSTEM	LAND DEVELOPMENT BENEFITS
Pittsburgh East Busway	59 new developments within a 1500-ft radius of station. \$302 million in land development benefits of which \$275 million was new construction. 80% is clustered at station.
Ottawa Transitway System	\$1 billion (\$C) in new construction at Transitway Stations.
Adelaide Guided Busway	Tea Tree Gully area is becoming an urban village.
Brisbane South East Busway	Up to 20% gain in property values near Busway. Property values in areas within 6 miles of station grew 2 to 3 times faster than those at greater distances.

SOURCE: Levinson et al., 2003.



(SOURCE: *Mass Transit—Bus Rapid Transit Shows Promise*, 2001)

Figure 9-2. Operating costs per vehicle revenue hour.

At the demand volumes found in most U.S. corridors, BRT can be the least expensive rapid-transit mode to operate *and maintain*. The major operating and cost difference between any form of rapid transit and local bus service is operating speed, not the size of the basic service unit. For example, all things being equal, local buses going 12 miles per hour in mixed traffic, stopping at every street corner, are half as productive as BRT vehicles or LRT trains making limited stops on a dedicated transit guideway where they might average 24 miles per hour.

The basic unit of capacity for BRT, an individual vehicle 40 to 82 feet long, is smaller than most LRT vehicles. This means that the number of BRT vehicles and drivers required to carry a given number of passengers past a point can be higher than with rail rapid transit, all things being equal. However, BRT line-haul services can be integrated with collection/distribution, meaning that the additional overhead costs of having separate rapid-transit, feeder, and circulator services can be eliminated. Also, the marginal costs of maintenance of way, signals, and power for BRT are either nonexistent or low. BRT vehicle maintenance costs are also relatively low (adjusted for capacity), and implementation of BRT usually does not mean staffing a wholly new maintenance and operations base. BRT vehicle operations and maintenance can also be competitively procured from any number of local transit providers.

### 9-3. FUNDING AND FINANCING OPTIONS

Like other forms of rapid transit, funding and financing of BRT systems can be accomplished through a combination of funding and financing mechanisms. Funding can be obtained from sources at the local, state, and federal level. In addition, innovative private-sector finance strategies and project delivery mechanisms may enable project sponsors to leverage additional funding from nongovernmental sources.

#### 9-3.1. Funding Sources

BRT projects may be funded through several categories of federal, state, and local funding. Several issues associated with government funding include the eligibility of BRT projects, competition with other transit-related projects or uses, and long-term commitment of funds for capital and operating expenditures related to BRT projects.

##### 9-3.1.1. Federal Funding Sources

Although there is no federal program specifically designed to fund BRT projects, federal funding for BRT projects is available from several FTA programs. These include the New Starts program, the Urbanized Area Formula Grants program, the Bus Capital program, and the Fixed Guideway Modernization program. In addition, funding for parts of BRT projects may be obtained from flexible multimodal capital assistance programs delivered as part of the federal highway program.

**Section 5309 New Starts Program.** FTA provides grants to state and local governments for the development of new and improved transit facilities and services, including BRT and fixed-guideway rail projects. FTA's Section 5309 New Starts program provides funds for fixed-guideway projects, including both BRT and rail. The New Starts program is discretionary, meaning that funding decisions are made on a project-by-project basis using information generated during the alternatives analysis/major investment study process.

The planning and project development process for New Starts projects is the forum for the development and refinement of the project justification and local financial commitment. FTA evaluates and rates candidate projects at specific milestones throughout each project's planning and development. New Starts projects must be justified based on project

justification criteria, shown in Table 9-5. Project justification criteria are initially developed as part of the alternatives analysis and are refined throughout the preliminary engineering and final design phases of project development.

New Starts project sponsors must also demonstrate adequate local support for the project, as measured by the proposed share of total project costs from sources other than from the New Starts program, the strength of the proposed project’s capital financing plan, and the ability of the sponsoring agency to fund operation and maintenance of the entire system as planned once the guideway project is built.

New Starts funding is limited under current law to projects that operate within a separate right-of-way. Although many BRT projects use separate rights-of-way, they may also use HOV lanes as well as city streets. Therefore, many BRT projects, or large elements of BRT projects, may not be eligible for New Starts funds. Rigid application of this requirement detracts from the flexibility afforded by BRT improvements that can be achieved outside of a separate right-of-way. This requirement also has the potential to skew alternatives analyses toward projects that are eligible for New Starts funds, as opposed to projects that meet specific performance goals.

The 2003 FTA budget proposal to Congress represents a change in FTA’s philosophy toward funding eligibility for New Starts funds. It includes provisions for New Starts funds to be used for all elements of BRT projects (including ITS improvements, vehicles and equipment, and stations) even if they are not on a dedicated running way.

The Section 5309 New Starts program is highly competitive. New Starts funds are extremely limited, and demand for these funds is significantly greater than the funds available. BRT projects face stiff competition from a huge “pipeline” of light-rail, heavy-rail and commuter-rail projects. Funding for additional projects is significantly constrained. Through 2001, only two BRT projects received Transportation Equity Act for the 21st Century funding commitments for construc-

tion from the current New Starts program, totaling about \$831 million (the South Miami-Dade Busway Extension and the South Boston Piers Transitway).

Several BRT systems that have been implemented or are under development have received federal funding for planning, engineering, or development through the New Starts program in the past, including the following:

- Pittsburgh—West Busway,
- Boston—Silver Line and South Boston Piers Transitway,
- Houston—Regional Bus Plan,
- Connecticut—New Britain–Hartford Busway,
- Virginia—Dulles Corridor Rapid Transit Project,
- Cleveland—Euclid Corridor Transportation Project, and
- Miami—South Miami-Dade Busway Extension

Funding for New Starts projects in Fiscal Year 2001 is shown in Table 9-6. Few projects have been considered for New Starts funding through Fiscal Year 2002, for several reasons. First, few BRT projects are ready for funding consideration. This is mainly due to the newness of the BRT concept and decisions by local governments that are responsible for conducting analyses of various alternatives and proposing projects for funding. Second, FTA’s ability to make new funding commitments for projects of any type is extremely limited because of limited resources. Finally, many BRT projects are not eligible for funding because projects must operate on a dedicated running way for exclusive use of transit and HOV.

**Section 5307—Urbanized Area Formula Grant Program.** Section 5307 funds are the main category of federal funds used for transit improvements at the state and metropolitan levels. BRT projects are eligible for Section 5307 funds, although they must compete with other transit-related uses at the local level. State agencies, local governments, and/or local transit agencies may apply for, receive, and

**TABLE 9-5 New Starts project justification criteria**

Criterion	Measure(s)
Mobility Improvements	<ul style="list-style-type: none"> <li>▪ Hours of Transportation System User Benefits</li> <li>▪ Low-Income Households Served</li> <li>▪ Employment Near Stations</li> </ul>
Environmental Benefits	<ul style="list-style-type: none"> <li>▪ Change in Regional Pollutant Emissions</li> <li>▪ Change in Regional Energy Consumption</li> <li>▪ EPA Air Quality Designation</li> </ul>
Operating Efficiencies	<ul style="list-style-type: none"> <li>▪ Operating Cost per Passenger Mile</li> </ul>
Cost-Effectiveness	<ul style="list-style-type: none"> <li>▪ Incremental Cost per Hour of Transportation System User Benefit</li> </ul>
Transit Supportive Land Use and Future Patterns	<ul style="list-style-type: none"> <li>▪ Existing Land Use</li> <li>▪ Transit Supportive Plans and Policies</li> <li>▪ Performance and Impacts of Policies</li> <li>▪ Other Land Use Considerations</li> </ul>
Other Factors	<ul style="list-style-type: none"> <li>▪ Project Benefits Not Reflected by Other New Starts Criteria</li> </ul>

SOURCE: "Advancing Major Transit Investments Through Planning Project Development," 2003.

**TABLE 9-6 Funding for New Starts projects, 2001**

Category of projects	Number of New Starts projects	Actual or proposed funding (millions)	Number of BRT projects	Actual or proposed funding (millions)
Projects with full funding grant agreements	26	\$8,296	2	\$831
Projects pending full funding grant agreement	2	157	0	0
Projects in final design	9	1,456	1	23
Projects in preliminary engineering	31	8,350	6	490
Other projects authorized	137	N/A	5	N/A
<b>Total</b>	<b>205</b>	<b>\$18,259</b>	<b>14</b>	<b>\$1,344</b>

SOURCE: *Mass Transit—Bus Rapid Transit Shows Promise, 2001.*

dispense funds for projects in designated transportation management areas.

Activities that are eligible for Section 5307 funding include the following:

- Planning, engineering design, and evaluation of transit projects and other technical transportation-related studies.
- Capital investments in bus and bus-related activities such as replacement of buses, overhaul of buses, rebuilding of buses, crime prevention and security equipment, and construction of maintenance and passenger facilities.
- Capital investments in new and existing fixed-guideway systems including rolling stock; overhaul and rebuilding of vehicles, track, and signals; communications; and computer hardware and software. All preventive maintenance and some ADA complementary paratransit service are considered capital costs.

Areas with populations over 200,000 may use these funds for capital projects. For example, in Fiscal Year 2003, MBTA planned to fund the Silver Line project with \$150 million in Section 5307 funds, about \$330 million in New Starts funds, and \$120 million in Massachusetts state bonds.

**Bus Capital Program.** The discretionary Bus Capital program refers to grants made to public bodies and agencies to assist in financing bus and bus-related capital projects that will benefit the country's transit systems. This program is characterized by a relatively large number of small grants. The funds may be used for the following:

- Acquisition of buses for fleet and service expansion,
- Bus maintenance and administrative facilities,
- Transfer facilities,
- Bus malls,
- Transportation centers,
- Intermodal terminals,
- Park-and-ride stations,

- Acquisition of replacement vehicles,
- Bus rebuilds or bus preventive maintenance,
- Passenger amenities such as passenger shelters and bus stop signs,
- Accessory and miscellaneous equipment such as mobile radio units, and
- Costs incurred in arranging innovative financing for eligible projects.

BRT is an eligible use for these funds, although Bus Capital program grants tend to be relatively small. Although these funds can be used in combination with other federal funds, such as New Start funds, this program is unlikely to be a significant contributor to BRT projects.

**Flexible Funds for Highway and Transit.** Flexible funds are categories of funds that may be used for either transit or highway purposes. This provision was first included in the Intermodal Surface Transportation Efficiency Act of 1999 and was continued with the Transportation Equity Act for the 21st Century. The idea of flexible funds is that a local area can choose to use certain federal surface transportation funds based on local planning priorities, rather than on a restrictive definition of program eligibility. Flexible funds include FHWA Surface Transportation Program funds and Congestion Mitigation and Air Quality Improvement Program funds and FTA Urban Formula funds. Among other things, Surface Transportation Program funds are provided to states to be used for capital costs of transit projects. Congestion Mitigation and Air Quality Improvement Program funds are generally available to states for transportation projects designed to help them meet the requirements of the Clean Air Act.

Flexible funds have provided a substantial new source of funds for transit projects. When FHWA funds are transferred to FTA, they can be used for a variety of transit improvements such as the following:

- New fixed-guideway projects,
- Bus purchases,

- Construction and rehabilitation of rail stations,
- Maintenance facility construction and renovations,
- Alternatively fueled bus purchases,
- Bus transfer facilities,
- Multimodal transportation centers, and
- Advanced technology fare collection systems.

These funds have been used for a variety of transit capital projects, but for only one BRT project. The initial South Miami-Dade Busway extension project was built entirely with flexible funds. In addition, the 11-mile busway extension is being built with \$39 million of flexible funds through the Florida Department of Transportation and New Starts funds.

### 9-3.1.2. State and Local Funding Sources

Because federal funding has not kept pace with inflation or supported the costs associated with federal mandates, transit agencies have increasingly looked to other sources of funding. Many states rely on at least two sources of revenue to fund transit, discretionary transfers from general funds or highway funds and dedicated sources such as lotteries, special taxes, or sales taxes. Transit systems in states with dedicated funding sources receive more consistent, predictable, and reliable state contributions.

A wide range of funding programs is also used at the local level to support the operations of public transit services. These include local sales taxes, local property taxes, general revenues, and other sources. Local funding sources may be used to fund capital improvements or long-term operating support. These funds may come from county sources, city or municipal budgets, or local transit or transportation authorities.

The legality and ease of implementing each type of local funding source will vary by state. Several evaluation criteria can be used to evaluate these supplemental local revenue sources. They address the financial, political, legal, burden, administration, and economic effects of the revenue sources listed above. The evaluation criteria are the following:

- **Revenue Generation**—Candidate funding sources are evaluated on financial criteria based primarily on revenue generation. The primary objective of a financial plan is to meet project costs. Associated financial considerations include stability/reliability of the funding source and growth potential.
- **Acceptance**—Following evaluation by revenue generation criteria, candidate funding sources are screened based on political/public acceptance. This is a subjective evaluation and requires significant input from individuals involved with the project. It frequently acts to eliminate poor alternatives and thus limit the number of funding alternatives for further consideration.
- **Legality**—Most funding candidates will require some type of legal action. This may entail enabling legisla-

tion at the state level or action by a city council. Realizing these requirements makes it essential that the funding sources carried forward in the financial plan provide sufficient revenue capacity.

- **Burden**—Candidate funding sources are evaluated based on the incidence of the levies used to generate revenues for project funding. This evaluation focuses on levies that target project users/beneficiaries. The evaluation also assesses the potential of passing through burden to nonresidents and assesses equity.
- **Economic Effects**—Evaluation of economic effects examines the impacts of funding sources and the form of the levy on the regional economy, especially those industry segments of the economy that are directly affected by a levy. The objective is to structure a funding package that limits negative economic effects by limiting any displacement of economic activity, which could occur when a levy alters pricing and consequently negatively affects demand and industry revenue.

### 9-3.1.3. Public-Private Funding Sources

A number of strategies have been developed and implemented for generating private funding for transit improvements. These strategies may include the use of transit assets to generate additional revenues or partnerships with private parties such as equipment manufacturers, investors, developers, retailers, and the users or groups within the community that benefit directly from the transit system. These strategies include the creation of special districts to capture the value of transit improvements to adjacent properties, leveraging private investment in capital equipment and transit vehicles, and joint development of land adjacent to transit stations in order to finance system improvements.

Because BRT can provide levels of service comparable to that of rail and has the demonstrated potential to stimulate higher-density transit-oriented development, public-private funding strategies can potentially be used for BRT projects. These strategies will have the most potential in areas that are experiencing high levels of growth and/or infill development and that are currently underserved by transit. Tools for determining the potential for such public-private financing tools include interviews with major landowners and developers to determine the potential value added to commercial development as a result of the BRT investment; analysis of available build-out maximum densities allowed under existing land use and zoning regulations; and examination of the redevelopment potential for properties within station areas based on current use, age and functionality of the structure, and site constraints.

**Tax Increment Financing Districts.** A tax increment financing (TIF) district is set up to encourage development and improvement of a specific area. The TIF district is estab-

lished for a set number of years and can involve residential, commercial, or industrial uses. At the beginning of the district's existence, the value of the property is assessed, and property taxes are collected on that amount. As the district develops, the value of the property increases, thereby increasing the taxes. This rise in property tax revenue is dedicated to necessary improvements to or around the district. Once these modifications are made to the area, the assessed property value will escalate again and generate more funds for further improvement of the TIF district. This cycle will continue for the lifetime of the district.

**Benefit Assessment Districts.** A benefit assessment district is composed of a number of properties defined by set boundaries. Inside the district's borders, each property is taxed or pays a fixed fee to generate money for improvements in the district. This can be a one-time fee or a recurring charge. The revenue produced by the district can be used to directly pay for the enhancements or to repay the bonds that were used to finance the project. The amounts of the assessments that are levied are directly related to the benefits that each property receives from the improvement, the distance of the property is from the improvement, and the cost of the improvement. The assessment fees will typically range from \$.05 to \$.45 per square foot. Economic assessments employ the user fee principle: those who benefit pay, and those who benefit the most pay the most.

Examples of special districts used for transit projects elsewhere include the following:

- **Los Angeles, California—Southern California Rapid Transit District.** Two benefit assessment districts were established on July 11, 1985, around the CBD station area and the Wilshire Boulevard/Alvarado station area. The district boundaries are a ½-mile radius out from the CBD and a ½-mile radius out from the Wilshire Boulevard district. These boundaries were established based on walking distance from the station. The purpose of the districts is to help fund the construction, maintenance, and operation needs of Metro Rail transit. All properties within the district borders pay the same assessment rate, \$.30 per square foot. The rates are to be reviewed at least every 2 years with the ceiling rate set at \$.42 per square foot. In 1998, the CBD station business improvement district generated \$11.5 million, whereas the Wilshire Boulevard Station district generated \$500,000.
- **Denver, Colorado.** Downtown Denver, Inc., manages the 16th Street Mall, a downtown, rubber-tired transit mall bordered by a mix of retail, high-rise office, and residential property opened in October of 1982. In order to fund the necessary maintenance costs of the mall, a benefit assessment district was formed that was made up of the properties immediately adjacent to the mall. The district encompasses 120 city blocks and is composed of 677 commercial property parcels, 2.6 million square feet

of retail space, 23 million square feet of office space, 14 hotels, 4,000 residential units, and 34,000 parking spaces. The district does not generate revenue to be used for construction purposes. Assessment rates for all properties in the district depend on the amount of land area occupied as well as distance from the mall. The rates vary from \$.05 to \$.45. In 1984, Downtown Denver, Inc. collected \$1.67 million; 1998 revenue reached \$2.2 million.

**Joint Development.** Joint development strategies are typically used to fund a specific transit facility (such as a BRT station at a major business center) but generally not used for overall system finance. Joint development occurs between a transit system and the immediate surrounding community, generally through ground and/or air rights leases of transit property for other development uses. The purpose is to secure a revenue stream for the transit system as well as promote appropriate growth in the station's vicinity.

Joint development has been used successfully in Brisbane along the South East Busway, although it has not been used widely for BRT systems in the United States. Some of the larger rail transit systems in the United States have used joint development successfully. These include rail systems in Washington, District of Columbia; Atlanta, Georgia; and Santa Clara Valley, California. The joint development arrangements of these rail systems are the following:

- The Washington Metropolitan Area Transit Authority has developed formal procedures for identifying and implementing joint development. In 1998, Washington Metropolitan Area Transit Authority participation in 26 projects generated \$5.5 million. The revenue has not increased in proportion with the number of projects because individual projects range in size and level of participation.
- In Atlanta, in 1985, IBM built a five-story tower office building adjacent to a Metropolitan Atlanta Rapid Transit Authority station. By 1991, the IBM tower had generated \$1.5 million in lease revenue to the Metropolitan Atlanta Rapid Transit Authority.
- In California, the Valley Transit Authority of Santa Clara has utilized joint development to create a new revenue stream for the transit authority while promoting economic development in the community. The Valley Transit Authority of Santa Clara, which operates light rail and bus services in the Silicon Valley region, has partnered in a major mixed-use development at the Ohlone-Chynoweth light rail station. Joint development provisions under the Transportation Equity Act for the 21st Century permitted the agency to use FTA funds to purchase a parking lot adjacent to the station. The Valley Transit Authority of Santa Clara now receives \$300,000 in annual revenue under a 75-year lease arrangement with an adjacent residential and retail development and uses those funds to meet additional transit-related needs.

### 9-3.2. Financing Options

#### 9-3.2.1. Leveraging Funding Through Debt Issuance

Financing BRT projects may be accomplished through financing mechanisms similar to those of other transit projects. Most major transit improvements, including BRT capital improvements, are financed through combinations of state and federal grants and/or long-term borrowing options that permit agencies to use public funds for debt financing.

Transit agencies often issue debt in order to generate revenue for capital purposes. Traditionally, this scenario pertains to the issuance of long-term debt that provides investors with both interest and principal payments. The benefit of traditional debt financing is the immediate receipt of revenue from the issuance.

One major problem of transit borrowing is how to raise funds for debt service. Fareboxes fall far short of providing enough revenues even for operating expenses, and, to be saleable, transit bond issues must be backed by non-fare revenue sources that lenders will accept as adequate and dependable. Examples of strategies for raising debt service include the following:

- ***Pledging Revenues of an Earmarked Tax or Taxes.*** Property and sales taxes are commonly used for this purpose.
- ***Pledging Surplus Revenue of Other Sources.*** This device has been used by bridge and tunnel authorities, which have issued their own bonds, backed by motor vehicle tolls, to build transit links.
- ***Bonds Issued by State and Municipal Governments.*** Debt service for these bonds is usually paid from general funds.
- ***Bonds Issued by Transit Agencies.*** Debt service may be shared among participating jurisdictions according to a formula. MBTA in Boston has issued this approach extensively.

The functions of financing transit capital and operating a transit agency need not necessarily be combined in the same agency. Borrowers may be municipal or county governments, state governments, or special districts or authorities with surplus revenues that can be pledged for debt service. This usually requires authorization of the state legislature and, in many cases, permission of holders of outstanding bonds.

#### 9-3.2.2. Federal Credit Programs— *Transportation Infrastructure Finance and Innovation Act (TIFIA)*

The TIFIA program has been established by the U.S. DOT to provide three forms of credit assistance to surface trans-

portation programs of national or regional significance. These forms of assistance include secured (direct) loans, loan guarantees, and standby lines of credit. The Transportation Equity Act for the 21st Century made a total of \$10.6 billion in lending authority available for surface transportation projects. As of 2002, approximately \$3.6 billion has been committed to projects and leveraged to support over \$15 billion in surface transportation projects.

To be eligible for the TIFIA program, projects also must generally cost at least \$100 million, or their cost must be equal to at least 50% of the amount of federal highway assistance funds apportioned for the most recent fiscal year to the state in which the project is located. The projects also must be supported at least partially by user charges or other dedicated revenues. Eligible transit projects include design and construction of stations, track, and other transit-related infrastructure; purchase of transit vehicles; purchase of intercity bus vehicles and facilities; construction of publicly owned intermodal facilities that are near or adjacent to the National Highway System; provision of ground access to airports or seaports; and installation of ITS systems.

To date, TIFIA has not been used for BRT projects. However, examples of transit projects that have used TIFIA to secure additional funding include the following:

- ***Tren Urbano, San Juan, Puerto Rico.*** TIFIA funding will enable Tren Urbano, a transit system under construction, to complete a 17-kilometer rapid rail system. The \$1.7-billion project will be assisted with a \$300-million TIFIA loan to the Puerto Rico Highway and Transportation Authority.
- ***Farley-Pennsylvania Station Redevelopment Project, New York City.*** This \$750-million project will convert the Farley post office building adjacent to the existing Pennsylvania Station into an intermodal facility and commercial center serving Amtrak, commuter rail, and subway passengers. The project will receive a TIFIA loan of \$140 million and a TIFIA line of credit of \$20 million.
- ***Metro Capital Program, Washington, District of Columbia.*** This project will help accelerate a 20-year, \$2.3-billion capital improvement program for the transit system in the nation's capital. The project will rehabilitate and replace vehicles, facilities, and equipment on the 103-mile Metrorail system. It will receive a \$600-million TIFIA loan guarantee.

### 9-3.3. Project Delivery Options

Transit agencies have used a variety of mechanisms for implementing transit capital projects that can be applied to BRT planning and implementation.

### 9-3.3.1. *Traditional Procurement*

Traditional design-bid-build procurement involves issuing separate requests for proposals and selecting independent contractors for each stage of the project. In such a procurement, a transit agency would likely procure a designer and a construction company in two separate steps. The entire design would have to be completed before the builder was selected and construction could begin. This timing leads to a lack of communication between the designer and the builder, which may result in frequent change orders and cost increases during construction.

### 9-3.3.2. *Design-Build Procurement*

In design-build procurement, the designer and builder would propose as a team, and there is only one initial procurement process. After the team is selected, the engineers (or architects) begin the design process. With the construction company involved in the design process, inputs, comments, and changes to the design occur early in the design phase.

This process reduces the need for change orders and can create additional efficiencies in the design and construction process. Once design is completed for early components of a project, construction can begin while design on the other components proceeds. Under this arrangement, critical aspects of the project, including purchasing and scheduling, are directed by a single source. As a result, construction delays and start-up difficulties are minimized, resulting in lower project costs and shorter completion times.

### 9-3.3.3. *Turnkey Arrangements*

Public agencies can contract with private companies to add finance, operations, and maintenance components to a contract. A transit agency would contract with a private developer to finance and oversee the design, construction, and operation of transit projects and facilities. After operating the project for a certain portion of time (thereby allowing the private partner to recoup its investment), the private company will transfer the asset back to the public sector.

Variations of this approach used for transportation projects include build-operate-transfer and design-build-operate-maintain. These projects are also referred to as “turnkey” projects because after building, operating, or maintaining the system, the private partner in effect “turns the keys” back over to the public.

### 9-3.3.4. *Applicability of Public-Private Partnerships to BRT*

Public-private project delivery approaches are most appropriate for projects with steady revenue potential, either

through fares or joint development opportunities. Most transit projects have limited farebox revenue potential, and the revenue stream will be subject to fluctuations in ridership. In addition, revenues from joint development or concessions may take place over a longer period of time and therefore are not sufficient for establishing early cash flow.

As a result, in order for a public-private venture for a transit project to succeed, some financial assistance from the public sector is typically required to allocate risk among the public- and private-sector partners for the project’s financial performance. These payments may take the form of loan guarantees, annual payments for a minimum level of ridership (sometimes called “shadow fares”), or shared funding for capital and operating costs.

One critical aspect of these projects is careful scoping and estimation of the project’s full cost. A review of areas likely to impact cost or schedule is required. The elements of risk—including construction costs, schedule, and ridership forecasts—must be accurately assessed by both the public and private parties. Responsibility for areas outside the control of the developer—such as redefined or changed conditions, environmental permits, or right-of-way acquisition—should remain with the public agency.

The delivery method used to develop and implement a project should be based on consideration of the following issues:

- Available financial resources,
- Complexity of the BRT project,
- Estimated cost,
- Amount of design control that the project sponsor would like to retain,
- Local contracting experience with public-private partnerships, and
- Existing relationships between potential partners.

These approaches have not been used extensively for transit projects in the United States, and to date they have not been used for implementing BRT projects in the United States. There is, however, potential for these strategies to be employed for BRT and rail-based rapid transit. One potential scenario for private development is that a BRT system would be developed as an interim strategy to establish ridership and revenue streams in a corridor with significant ridership potential. The BRT project could be converted later to a rail-based system if warranted by ridership demand and financial performance.

An example is the York regional government outside of Toronto, Canada, which is employing a public-private partnership approach to develop the York Rapid Transit Project, a multimodal rapid-transit project that will include the development of BRT in several major corridors. The private partner is a consortium of engineering and construction companies, equipment manufacturers, a transit operator, and a financial institution.



**9-4. INCREMENTAL DEVELOPMENT OF BRT PROJECTS**

BRT has tremendous potential for incremental (or staged) development and can be used to get rapid-transit operating as quickly as possible with the least amount of funds, while preserving options for later expansion and upgrading. In constructing BRT, it is not necessary to include all the final elements before beginning operations; it is possible to phase in improvements over time. Improvements such as signal prioritization and low-floor buses, which improve capacity and bus speed, can be added incrementally and still have significant effects.

In many cases, it may be useful to identify a segment for immediate, early implementation. This early action is essential to retain sustained community support and continuity of public agency staff. This can demonstrate BRT’s potential benefits as soon as possible to riders, decision makers, and the public, at relatively little cost, while still enabling system expansion and possible future upgrading (e.g., to more technologically advanced vehicles). The time frame for which a BRT project is implemented will be based on demand, availability of right-of-way, sources of capital and operating funds, and community support.

As an example, the initial segment of a BRT system could include curb bus lanes that may be upgraded to busways in the future. BRT service along a busway does not preclude ultimate conversions to rail transit when and if such a conversion is warranted by ridership or other considerations. A BRT line can serve as a means of establishing a transit market for a possible future rail line.

In developing a BRT system incrementally, it may be desirable to maximize the initial system by adopting an “outside-in” development strategy. This approach was used in Ottawa to provide broader BRT coverage. It has proven more cost-effective in attracting riders and influencing travel choices than the traditional concentration on the shorter, most costly inner city segments. Each stage of BRT system development should contain a well-packaged series of BRT elements and should produce tangible benefits. Early action is essential to maintain community support.

**9-4.1. Packaging BRT Elements**

Examples of packaging BRT elements are shown in Table 9-7. This table illustrates how BRT features could be packaged in a system for a BRT application of relatively modest

**TABLE 9-7 Packaging BRT elements—modest-demand and modest-cost BRT system**

SERVICES	STATIONS	VEHICLES	RUNNING WAY	SYSTEMS
PRIMARILY LOCAL	SIMPLE STOPS	NO SPECIAL TREATMENT	MIXED TRAFFIC	RADIOS, ON-BOARD FARE COLLECTION
MIXED LIMITED-STOP, LOCAL	SUPER STOPS	SPECIAL SIGNAGE	DEDICATED ARTERIAL CURB LANES, COMPETING TURNS ALLOWED	AVL FOR SCHEDULE ADHERENCE
ALL-STOP (LOCAL), MIXED LOCAL/ EXPRESS	ON-LINE AND OFF-LINE STATIONS, SIGNIFICANT PARKING FOR TRANSIT PATRONS	DEDICATED VEHICLES, SPECIAL LIVERY	DEDICATED FREEWAY MEDIAN LANES, MERGE/WEAVE ACCESS/EGRESS	ITS PASSENGER INFORMATION, FARE COLLECTION
POINT-TO-POINT EXPRESS	TRANSFER/ TRANSIT CENTERS	DEDICATED VEHICLES, UNIQUELY SPECIFIED, (E.G., DOUBLE-ARTICULATED BUSES, HYBRID PROPULSION)	FULLY DEDICATED LANES, EXCLUSIVE FREEWAY ACCESS/EGRESS	ITS VEHICLE PRIORITY
	INTERMODAL TRANSFER/ TRANSIT CENTER	MECHANICAL OR ELECTRONIC GUIDANCE	PARTIAL GRADE SEPARATION	ITS VEHICLE LATERAL GUIDANCE
		FULLY ELECTRIC PROPULSION SYSTEM	FULL GRADE SEPARATION, CURBED/ STRIPED/ CABLED FOR GUIDANCE	ITS AUTOMATION, ELECTRIC POWER SYSTEM
			OVERHEAD POWER CONTACT SYSTEM	

SOURCE: Zimmerman, 2001.

cost, appropriate in a low- to medium-demand operating environment. Such a system would likely include mixed types of bus service; super stops; standard vehicles in special livery (paint scheme); a mix of dedicated arterial, highway, and mixed traffic running ways; and standard systems such as radios and on-board fare collection.

Where a particular application would be in the continuum shown in Table 9-7 is dependent on the following operating environment characteristics:

- The nature of current and future land use and demographic characteristics (population, employment, and densities);
- Current and expected future transit markets, such as origin-to-destination patterns, expected rapid-transit ridership, and total and maximum load point volumes;
- Right-of-way (stations and running way) availability and characteristics (e.g., width, length, number and types of intersections, traffic volumes, and ownership); and
- Availability of capital, operating, and maintenance funds.

Table 9-8 illustrates a similar packaging of BRT elements, but for a high-demand, high-cost BRT application. For the BRT application described in the table to be justified, there would need to be a relatively large market and an operating

environment that allowed the highlighted package to be implemented cost-effectively for the size of that market. At this level of development, a BRT system would include mixed local and express services and point-to-point expresses; developed on-line and off-line stations with parking (possibly with transfer centers); uniquely developed rail-like vehicles; a fully dedicated right-of-way; and ITS systems for off-board fare collection, passenger information, and transit vehicle priority. Table 9-9 shows how several BRT projects have packaged BRT elements.

It is essential that BRT systems include all the elements of any high-quality, high-performance, rapid-transit system. These elements should be adapted to BRT's unique characteristics, especially its service and implementation flexibility. There is a need to focus on service, station and vehicle features and amenities, and integrated system and "image" benefits, rather than merely costs.

#### 9-4.2. Staged Development

As described above, BRT offers the flexibility to be developed incrementally in several stages. Staged development of a BRT system is highly dependent on demand, market

**TABLE 9-8 Packaging BRT elements—high-demand and high-cost BRT system**

SERVICES	STATIONS	VEHICLES	RUNNING WAY	SYSTEMS
PRIMARILY LOCAL	SIMPLE STOPS	NO SPECIAL TREATMENT	MIXED TRAFFIC	RADIOS, ON-BOARD FARE COLLECTION
MIXED LIMITED-STOP, LOCAL	SUPER STOPS	SPECIAL SIGNAGE	DEDICATED ARTERIAL CURB LANES, COMPETING TURNS ALLOWED	AVL FOR SCHEDULE ADHERENCE
ALL-STOP (LOCAL), MIXED LOCAL/ EXPRESS	ON-LINE AND OFF-LINE STATIONS, SIGNIFICANT PARKING FOR TRANSIT PATRONS	DEDICATED VEHICLES, SPECIAL LIVERY	DEDICATED FREEWAY MEDIAN LANES, MERGE/WEAVE ACCESS/EGRESS	ITS PASSENGER INFORMATION, FARE COLLECTION
POINT-TO-POINT EXPRESS	TRANSFER/ TRANSIT CENTERS	DEDICATED VEHICLES, UNIQUELY SPECIFIED, (E.G., DOUBLE-ARTICULATED BUSES, HYBRID PROPULSION)	FULLY DEDICATED LANES, EXCLUSIVE FREEWAY ACCESS/EGRESS	ITS VEHICLE PRIORITY
	INTERMODAL TRANSFER/ TRANSIT CENTER	MECHANICAL OR ELECTRONIC GUIDANCE	PARTIAL GRADE SEPARATION	ITS VEHICLE LATERAL GUIDANCE
		FULLY ELECTRIC PROPULSION SYSTEM	FULL GRADE SEPARATION, CURBED/ STRIPED/ CABLED FOR GUIDANCE	ITS AUTOMATION ELECTRIC POWER SYSTEM
			OVERHEAD POWER CONTACT SYSTEM	

SOURCE: Zimmerman, 2001.

**TABLE 9-9 Elements of BRT in the FTA demonstration projects**

	Boston	Charlotte	Cleveland	Washington, D.C., Dulles <sup>a</sup>	Eugene	Hartford	Honolulu	Miami	San Juan	San Jose
Busways		•			•	•		•		
Bus lanes	•	•	•			•		•		
Bus on HOV-Expressways		•		• <sup>a</sup>			•		•	
Signal priority		•	•	•	•		•			
Fare collection improvements			•	•	•					
Limited stops	•		•	•	•			•		•
Improved stations & shelters		•	•	•	•	•	•	•		•
Intelligent transportation systems	•	•	•	•	•	•	•	•	•	•
Cleaner/quieter vehicles	•		•		•					

NOTE:  
 Individual elements may change as demonstrated projects evolve.  
<sup>a</sup>Washington, D.C., includes the use of a limited-access airport road.  
 SOURCE: *Mass Transit—Bus Rapid Transit Shows Promise*, 2001.

characteristics, and the availability of capital and operating funds. Figure 9-3 illustrates how a BRT system can be developed by (1) extending or upgrading the system on the same corridor and (2) providing BRT in other corridors. Once an initial BRT segment is operational, it can be upgraded and/or extended through the following steps:

- Adding elements or features;
- Upgrading to more advanced versions of key elements such as vehicles, stations, or fare collection systems;
- Relocating services to an off-road running way; and
- Extending the system corridor (e.g., the Ottawa Transitway or South Miami-Dade Busway Extension).

Alternatively, BRT can be developed in another corridor. As additional corridors become available and land uses and population demographics change, the type, frequency, and route of busway services can be adapted. Additional access points to a line haul busway can be added to provide service to additional markets, additional stations can be constructed as adjacent areas develop, or the busway can be extended along the same route or connected to another route.

Several BRT systems in the United States have had segments of the system planned, designed, and implemented incrementally. For example, the Port Authority of Allegheny County opened the busways in Pittsburgh in several stages, as shown below.

South Busway	4.3 miles	1977
East Busway	6.8 miles	1983
West Busway	5.6 miles	2000
East Busway extension	2.3 miles	Under construction

In Boston, MBTA is developing the Silver Line system in several stages also.

Section A	1.1 miles, mainly in tunnel	2004
Section B	2.2 miles, surface route	2002
Section C	0.8 miles, all in tunnel	2008

Any staged additions or alterations to an operational busway should be planned or designed such that the operations of the working busway are not adversely affected. Construction can potentially impact busway ridership. The impacts should be mitigated as much as possible to avoid disrupting services.

**9-4.3. Possible Conversion to Rail Transit**

One of the benefits of BRT is the potential to upgrade the system to a higher-capacity mode (such as light rail). The move to rail is facilitated if provisions for rail are designed into the BRT system from its inception, subject to cost-effectiveness and funding. If developed incrementally, BRT can be used to reserve right-of-way, build transit markets, spur transit-oriented development, and build community support.

If BRT is being planned and designed for future conversion to rail transit, the running way should be designed initially to meet rail-transit operating requirements. This can reduce long-term right-of-way costs and minimize costly alterations to the surrounding road network.

The most likely scenarios for converting BRT to rail are as follows:

- Locations where resources permit and demand warrants. For example, a “feeder” busway can be converted to rail in order to extend the rail system.

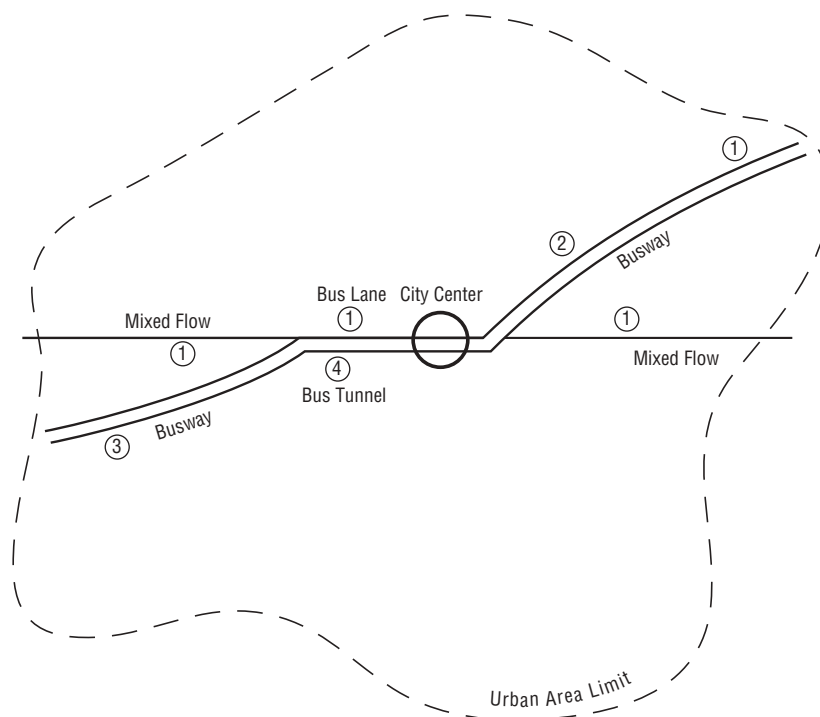


Figure 9-3. Illustrative incremental development of BRT.

- Locations where the BRT was built as a “first stage” operation during the construction period for rail transit.
- Locations where rail transit is built in another corridor, and the conversion of BRT to rail would provide integrated and through rail service.
- Locations where peak-hour peak-direction passenger volumes exceed 7,500 to 10,000 passengers per hour on a busway.

With the introduction of a higher-capacity mode such as LRT, a number of systems must be fully operational at the commencement of service. These include fare collection, traffic signal preemption, electric supply, and communications. Failure to fully introduce these systems to be fully introduced at the time that an LRT service becomes operational will lead to poor performance of the new system.

Introducing aspects of a future service as part of the BRT system allows a transit agency the opportunity to “fine tune” components of the system. Various components can then be fully operational at the time that the higher-capacity mode is introduced, and a market for the transit service has been established. BRT also allows time for more in-depth analysis as to whether the investment in a rail-based system is appropriate.

## 9-5. INSTITUTIONAL ARRANGEMENTS

Many BRT projects, like transit properties, operate across multiple jurisdictional boundaries and involve multiple stake-

holders. These stakeholders typically bring their own priorities and agendas to the planning process. To work effectively, most BRT systems require transit agencies to reach agreement on issues related to infrastructure, technologies, operations, and responsibilities.

For any rapid transit system to be successful, a great deal must be known about the institutions that will plan, build, and operate the system. There is a wide and varied group of institutions that may be involved in the development of a BRT project, including the following:

- Federal, state, local or regional public officials;
- State transportation, environment, or planning departments;
- Transit agencies and operators;
- Local planning, transportation, and economic development agencies;
- Local traffic engineering or public works departments;
- Police services involved in safety and traffic enforcement;
- Private developers or major landowners at station areas;
- Large private institutions such as hospitals, universities, commercial/retail organizations, or tourism facilities; and
- Representatives of local environmental or user groups.

Issues raised by any institution can have significant impacts on the location, alignment, or cost of a BRT project. These issues can also affect location of stations, integration with the regional transportation system, environmental constraints, staging options, and whether BRT will be considered a viable option at all.

Intergovernmental agreements may be needed for agencies to reach agreement on the roles and responsibilities associated with a BRT project, including operation of the BRT system, traffic operations and signalization, zoning and land use planning, parking policies, fare policy, enforcement, finance, and construction of BRT facilities. These may also require an agreement for the shared use of funds for the development and operation of a BRT system.

No single governance scheme and/or intergovernmental agreement will be appropriate for all areas. In some areas, the local transit property might be the agency that implements a busway. In some cases, the implementation agency might be a county or state DOT. A state DOT might build and maintain a busway that one or more transit services may use for operations. It is also possible that a private party might build and operate a busway.

Examples of institutional arrangements for existing BRT systems include the following:

- The Los Angeles Metro Rapid system was developed by the Los Angeles County Metropolitan Transportation Authority with the Los Angeles Department of Transportation. The Los Angeles County Metropolitan Transportation Authority operates the buses, and the City controls street traffic operations.
- Ottawa's Transitway was initially developed by OC Transpo in conjunction with the City of Ottawa and the Province of Ontario. OC Transpo is now one of four sections within the Department of Transportation, Utilities, and Public Works that responds to the Ottawa City Council through the City Manager.
- The Pittsburgh busways were developed by the Port Authority of Allegheny County in cooperation with the City of Pittsburgh and the state of Pennsylvania.

Several of the most prevalent institutional issues that arise during BRT development include the following:

- Local and business community opposition to restricting or removing parking spaces for BRT use;
- Availability and acquisition of right-of-way or physical space;
- Integration of multiple priorities, objectives, and agendas;
- Impacts of BRT on roadway operations;
- Finding political champions to support BRT;
- Gaining community support for transit-oriented development;
- Educating the public on BRT; and
- Managing perceptions and expectations.

A number of additional issues may apply to specific types of BRT systems. Institutional issues associated with BRT operating in mixed traffic include concerns over street depart-

ments and highway departments relinquishing control of their infrastructure, reaching an agreement on station area enhancements, and capital costs associated with BRT.

Institutional concerns associated with BRT operating in exclusive facilities include BRT being viewed as a top-down solution to local transportation problems, community opposition to BRT, lack of information on the effects of BRT on land use, and BRT being perceived by developers as less permanent than other modes and therefore having less of an effect on land use.

### 9-5.1. Integration with Regional Systems

A successful BRT project that achieves its full potential calls for more than building a bus-only lane or even building a dedicated busway. The integration of the entire range of rapid-transit elements into the larger regional system, including the development of a unique system image and identity, are equally, if not more, important.

The integration of BRT facilities with other regional transit facilities can be considered in five major categories:

- The physical location of stations or terminals and pedestrian connection between facilities,
- Timetables and route maps,
- Fare structure and policy,
- Passenger information systems, and
- Cooperation rather than competition between modes.

The physical location of the BRT system and other local and regional services is critical because they need to fit together in a logical way. Many examples exist of facilities run by different entities that overlook the benefits of physically integrating their respective services. Each group tries to optimize its own location without considering potential users. Pedestrian and bicycle connections are particularly important and are often overlooked in the planning and design process.

As services are integrated, timetables and route maps are items in which integration is noticed by transit patrons. They should be seamlessly integrated with common styles and information. BRT routes should have a clear identity in timetables and route maps.

A common fare structure and policy should be established, and cooperative agreements between agencies should be negotiated. This is difficult to establish in regions with many cities, counties, private operators, and governments with completely different fare policies. Developing "revenue neutral" proposals, in which no agency is worse off than another after the integration, can be extremely beneficial to all partners.

Information systems, like fare structure and timetables, should be transparent to the user and convey the notion of a single integrated system. A fully integrated system should also reduce competition between modes. Ideally, the BRT system

might evolve into the backbone of the regional transit system, with all the elements described above in place.

## 9-6. BRT-SUPPORTIVE POLICIES

BRT should be viewed as an important community asset that improves mobility and livability. Therefore, land use and parking policies should be established to support BRT investments and reinforce ridership.

### 9-6.1. Land Use Policies

BRT and land use planning for station areas should be integrated as early as possible and done concurrently. Recent experiences illustrate that without strong, consistent, long-term support for planning that actively encourages and provides incentives for transit-supportive development in the vicinity of existing and future rapid-transit facilities, these facilities may never be successful in attracting adequate ridership buses. Any high-cost, long-term investment in transit infrastructure—whether it is subway, BRT, or new LRT—runs the risk that the development needed to support the investment will not materialize. These risks can be minimized through the implementation of strong land use and economic incentive policies.

In several communities with BRT systems, local governments have implemented land use planning policies that encourage development near BRT facilities. In the Ottawa-Carleton region, centers for major activities, such as regional shopping and employment, are required to locate near the busway. In Curitiba, the arterial median busways are integral parts of the structure axes along which high-density development has been fostered. Adelaide and Brisbane have also demonstrated that BRT can have development benefits similar to the benefits resulting from rail transit when effective coordination of land use planning and BRT development is taken into consideration from the outset.

Land use policies or zoning regulations should also be based on providing incentives for developers to build transit-oriented development near BRT stations, with an appropriate mix of land uses and adequate pedestrian connections. Although redevelopment of existing land uses only occurs under appropriate market conditions, such incentives can help stimulate real estate development that coincides with the implementation of the BRT system. A “transit overlay” zoning district may be an appropriate strategy for encouraging transit-oriented development in BRT corridors. Density bonuses may also promote mixed residential and commercial development around transit stations.

For the Dulles Corridor Rapid Transit project, a proposed BRT/rail project in Fairfax County, Northern Virginia incorporated changes into the comprehensive plan (which were subsequently adopted in the county’s zoning ordinance) designed to stimulate development at station areas. Density bonuses were provided for residential and commercial development of parcels within a ¼ mile of station areas, and slightly lower density bonuses were allowed for properties within ½ mile of station areas. For properties within ¼ mile of the stations, up to 40 dwelling units per acre of residential development are allowed or up to a 1.5 floor-area-ratio for office development. The bonuses encourage a mix of residential and commercial uses, as well as provisions for affordable housing and recreation. The density bonuses are triggered once construction of the BRT system commences.

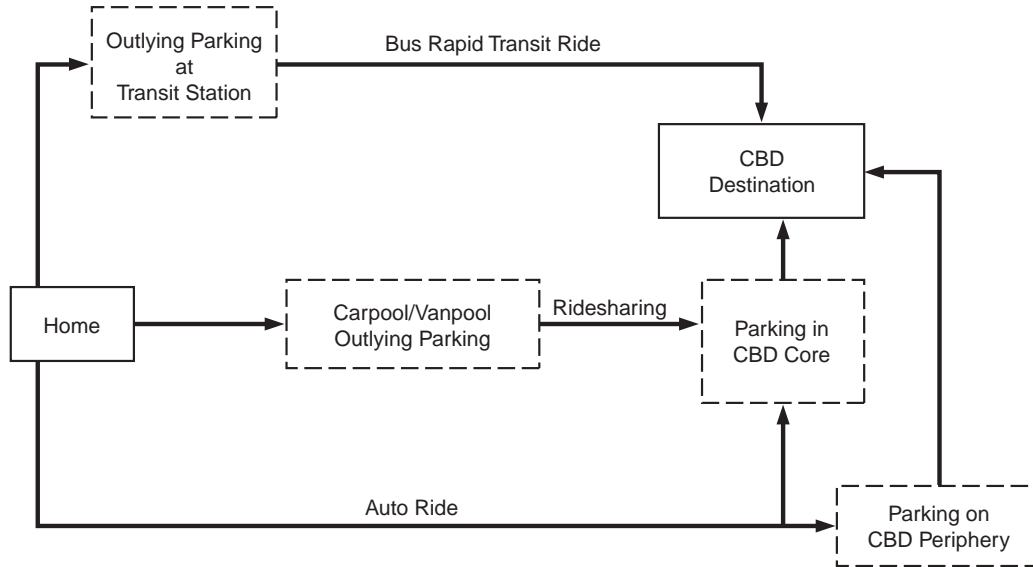
Although land use policies can be essential for stimulating transit-oriented development, the impacts of these policies on traffic, public services, and neighborhoods must be carefully considered. These impacts must be balanced with the long-term impacts on land use patterns, economic development, and travel patterns within the region.

### 9-6.2. Parking Policies

Ample parking should be provided along busways, especially at outlying stations. Parking supply can expand the catchment area and reduce the need for extensive feeder bus service in low-density residential areas. Downtown parking supply and rapid-transit-related parking are related; an increase in one implies a decrease in the other. Studies have found an inverse relationship between the supply of downtown parking per employee and the proportion of CBD commuter trips by transit. Therefore, downtown parking supply should be limited where major BRT investments are planned. Such CBD parking supply constraints are in effect in several large cities. These may take the form of a “ceiling,” as in downtown Boston, or reduced zoning requirements for parking spaces, as in Ottawa and Seattle.

Achieving such a policy requires that a large proportion of CBD workers commute by automobile to outlying BRT stations and that adequate parking space is available. Thus, the preferred commuter parking policy option along BRT lines is to maximize the number of park-and-ride spaces, as shown in Figure 9-4. Care must be given so that extensive parking does not preclude joint development opportunities.

Regular zoning requirements should be modified to reflect both transportation and development needs. Ranges in the maximum and minimum spaces for each land use can be established. Illustrative parking guidelines for rapid-transit systems are shown in Table 9-10. These guidelines suggest decreasing the number of allowable parking spaces as the distance between the activity center and transit station decreases.



(SOURCE: Weant and Levinson, 1991)

Figure 9-4. Commuter parking policy options.

TABLE 9-10 Illustrative parking policies for major transit corridors

Land-Use	Activity	Criterion Unit	Number of Spaces per Unit by Distance from Transit Stop					
			0–500 Feet		500–1,000 Feet		1,000–1,500 Feet	
			Minimum Required	Maximum Allowable	Minimum Required	Maximum Allowable	Minimum Required	Maximum Allowable
Residential	Single family	Housing unit	0.5	1.0	0.7	1.0	0.8	1.3
	Multi-family	Housing unit	0.4	1.0	0.6	1.0	0.8	1.3
Commercial	General office	Gross floor area (GFA), 1,000 sq ft	–	2.0	1.0	2.0	1.7	2.9
	Medical/Dental office	GFA, 1,000 sq ft	–	3.3	1.7	3.3	2.5	4.0
	Retail	GFA, 1,000 sq ft	2.0	3.3	2.5	3.3	3.3	5.0
	Restaurant	Seats	–	0.17	0.17	0.25	0.17	0.25
	Hotel/Motel	Rental units	0.7	1.0	0.7	1.0	0.7	1.0
Industrial	Manufacturing, warehouse, wholesale	Employees	0.2	0.33	0.25	0.33	0.33	0.5
Institutional <sup>a</sup>	Auditorium	Seats	0.13	0.2	0.13	0.2	0.14	0.25
	Hospital	Beds	0.80	1.0	0.80	1.0	1.0	1.4
	Church	Seats	0.14	0.2	0.14	0.2	0.14	0.25
Educational	Elementary and junior high school	Classroom and office	0.7	1.0	0.8	1.0	0.8	1.0
	Senior high school	Classroom and office	0.7 <sup>b</sup>	1.0 <sup>d</sup>	0.8 <sup>b</sup>	1.0 <sup>d</sup>	0.8 <sup>c</sup>	1.0 <sup>e</sup>
	College and university	Classroom and office	0.7 <sup>b</sup>	1.0 <sup>d</sup>	0.8 <sup>b</sup>	1.0 <sup>d</sup>	0.8 <sup>c</sup>	1.0 <sup>e</sup>

<sup>a</sup> Where public use of auditoria is likely, specific auditorium standards should apply.

<sup>b</sup> Plus 1 space per 10–15 students, except where constrained by policy.

<sup>c</sup> Plus 1 space per 8–10 students, except where constrained by policy.

<sup>d</sup> Plus 1 space per 8–10 students, except where constrained by policy.

<sup>e</sup> Plus 1 space per 5–8 students, except where constrained by policy.

SOURCE: *An Access Oriented Parking Strategy*, 1974.

**9-7. CHAPTER 9 REFERENCES**

- “Advancing Major Transit Investments Through Planning Project Development” (Version 1.1). Federal Transit Administration, Office of Planning, Washington, DC (January 2003).
- An Access Oriented Parking Strategy*. Prepared for the Massachusetts Department of Public Works in cooperation with FHWA. Wilbur Smith and Associates (July 1974).
- Levinson, H., S. Zimmerman, J. Clinger, S. Rutherford, R. L. Smith, J. Cracknell, and R. Soberman. *TCRP Report 90: Bus Rapid Transit, Volume 1: Case Studies in Bus Rapid Transit*. Transportation Research Board of the National Academies, Washington, DC (2003).
- Mass Transit—Bus Rapid Transit Shows Promise*, Report GAO-01-984. U.S. General Accounting Office (September 2001).
- Weant, R., and H. S. Levinson. *Parking*. Eno Foundation for Transportation, Westport, CT (1991).
- Zimmerman, S. *BRT—A Primer*. Paper prepared for ITE Annual Meeting, Chicago, IL (August 2001).
-



**APPENDIX A  
BUS CAPACITY**

A-1. GENERAL CONSIDERATIONS .....	A-2
A-1.1. Basic Relationships.....	A-2
A-1.1.1. Passenger Capacity of a Bus Stop.....	A-4
A-1.1.2. Passenger Capacity of a Bus Route .....	A-5
A-1.1.3. Illustrative Examples.....	A-6
A-1.1.4. Outlying Stops/Stations .....	A-7

**APPENDIX A  
BUS CAPACITY**

This appendix sets forth approaches to estimating the capacity of a bus stop or route. Further, more detailed discussions can be found in NCHRP 155<sup>(1)</sup>, the 1985<sup>(2)</sup> and 2000<sup>(3)</sup> Highway Capacity Manuals and the Transit Capacity Manual.

**A-1. GENERAL CONSIDERATIONS**

The capacity of a bus route is determined by the capacity of the heaviest used bus stop, or the capacity of the bus line. Generally, passenger boardings and interchange volumes during peak periods at the major loading and unloading points governs a bus route's capacity. The basic factors include (1) the service times at stops, (2) the minimum safe spacing between successive buses, (3) the number of seats and standees on each bus, (4) the green time per cycle available, and (5) specified failure rates.

These factors are influenced by vehicle design features including the number and size of doors, floor height, and interior seating configuration; fare collection practices; right-of-way interferences, (including junctions and traffic signals); the number and design of loading areas; operating policies pertaining to layover/recovery times at key stops and terminals, and allowable standees.

As a general rule, a BRT route with a relatively uniform distribution of boarding passengers among stops will usually have a higher capacity than where passenger boarding is concentrated at one or two stops. Operations at maximum capacity tend to strain the system, and do not allow for variations in demand, or bus operations; they should be avoided.

**A-1.1. Basic Relationships**

The capacity of a bus stop (in people per hour) with the number of berths, passenger capacity per vehicle, and amount of time available for movement. It varies inversely with the dwell time per stop and the clearance interval between buses.

The buses per berth per hour can be estimated by the following formulas:

1. Uninterrupted Flow

$$C_b = \frac{3600}{(1 + C_v Z) + tc} \quad (1)$$

2. Interrupted Flow

$$E_b = \frac{g}{B \left( \frac{g}{c} + Z_a C_v \right) + tc} \quad (2)$$

- Where g = green  
 C = cycle length  
 C<sub>v</sub> = coefficient of dwell times variation ~ 0.6  
 D = Dwell time  
 tc = clearance time in seconds (usually 10 to 20 seconds)  
 Z<sub>a</sub> = one tail value of standard normal variation  
 E<sub>b</sub> = number of buses per berth per hour

Typical values for Z<sub>a</sub> are given in Table A-1. Thus, for a 25% failure rate (defined as level of service E) the Z<sub>a</sub> value would be 0.675.

The dwell time in three equations can be estimated from field observations or computed as follows:

- D = aA for A Alighting passengers (A) (3)  
 D = nB for B Boarding passengers (B) (4)  
 D = (aA + bB)T for combined board through a single door, where T is an assumed Turbulence factor is equal to about 1.2 a and b are alighting and boarding coefficients respectively

Table A-2 gives the resulting berth capacities per bus berth in buses per hour for various failure rates, assuming a clearance time (tc) of 15 seconds.

For an average dwell time of 30 seconds, and 25% failure, the capacity is 63 buses per berth per hour for uninterrupted flow and 43 for interrupted flow. If the failure rate is 5% the corresponding values are 48 and 30 buses per berth respectively.

The capacity of a bus stop in buses per hour is the product of the capacity per berth and the number of effective berths.

$$C_v = C_p N_b \quad (3)$$

- Where: C<sub>b</sub> = Capacity of a single berth  
 N<sub>b</sub> = No effective berths  
 C<sub>v</sub> = Capacity of stop in buses per hour

The berth efficiency factors for multiple on-line and off-line stops are given in Table A-3.

The off-line stops apply when there is independent entry and exit – e.g. buses are able to overtake and pass each other and off-line values apply where independent entry is not possible. Thus, a three berth stop would have 2.45 to 2.60 effective berths, while a 5-berth on-line stop would have 2.75 to 3.75 effective berths.

**A-1.1.1. Passenger Capacity of a Bus Stop**

The maximum number of passengers per berth per hour can be estimated by multiplying the berth capacity in buses per hour, by the boarding passengers per bus.

$$P_b = C_B B \quad (4)$$

- Where: B = boarding passengers per bus  
 C<sub>B</sub> = berth capacity buses/berth/hour  
 P<sub>b</sub> = passenger/berth/hour

The number of passengers per stop becomes P<sub>b</sub> N<sub>b</sub>. Conversely, the number of effective berths to serve J passengers per hour becomes the ratio of J to P<sub>b</sub>.

The number of boarding passengers per bus normally governs the dwell times. Thus, when either boarding volumes, or dwell times are known, the other can be readily determined. Thus, for a 30-second dwell time and an assumed 3 second passenger service time, there would be 10 boarding passengers per bus. Thus, for 3 berths (2.45 effective berths) a linear stop could serve  $2.45 \times 43 \times 10$  for uninterrupted flow or 1050 passengers per hour (with interrupted flow and 25% failure).

#### **A-1.1.2. Passenger Capacity of a Bus Route**

The passenger capacity of any busway, bus terminal approach system, downtown bus street, or bus lane is governed by the number of buses that can be processed through the busiest point of boarding, the boarding passengers they serve, and the ability to receive additional passengers between this stop and the maximum load section. Thus, the distribution of passenger boarding along a route becomes significant, as well as the allowable passenger loads per bus.

Generally, the maximum load section established the bus frequency in a corridor; enough stopping locations and berth capacities at each stop should be sufficient to meet this frequency.

1. The maximum peak hour passenger volumes can be estimated as a function of the number of buses that can be processed at the busiest stop, and assuming that each bus is filled to its schedule-design load when it reaches the maximum load point. This assumption is reasonable only for conditions of dispersed loading. Thus, if  $C^1$  are the number of buses processed through the controlling stop, and  $S$  represents the number of passenger spaces per bus, then the number of passengers becomes  $C^1$ .

2. A more realistic assumption is to assume that the passengers processed at the busiest stop represent a percentage of the maximum load section flow. Thus if  $Q$  represents the

passengers boarding at the controlling stop and they represent  $X\%$  of the total,  $P_bNB/X$  represents the service volumes through the maximum load section.

#### **A-1.1.3. Illustrative Examples**

Table A-4 gives sample computations:

1. The first step is to define the type of bus, the door channels available for boarding, and the method of fare collection. From there, it is possible to estimate the service times. Illustrative values are shown in the table. Using a 3.5 second dwell time for a single-door bus with fare payment on bus as a base, the service times are progressively reduced to account for use of multiple doors and prepayments. For example, 2 boarding channels would have about 0.7 the service time per passenger per channel as a single door. Obviously, these service times should be keyed to specific conditions.

2. The passenger boarding per bus should be estimated during the peak 15-minute periods.

3. Dwell times should be computed by multiplying the service times per person by the passengers per bus. They should be increased to reflect variations, and adjusted for the effect of traffic signals. The resulting "effective dwell" times should be added to the clearance time.

4. The buses per berth per hour should be computed based upon equations 1 and 2, and then multiplied by the number of effective berths. The passengers per berth per hour should be obtained by multiplying the passengers per bus by the buses per berth.

5. Finally, the passenger volumes past the busiest load point can be obtained based upon the likely % of the peak passenger volumes boarding at the busiest stations.

The table clearly shows that the number of people that can be accommodated depends heavily on the number of door channels available for boarding, the methods of fare collection,

and the ability to disperse boardings in major activity areas such as the city center. All are essential for effective BRT operations.

In some situations, it may be necessary to spread stops for alternate groups of bus-routes. The total number accommodated by a series of “split stops” represents the capacities for each stop. A 10 to 20% downward adjustment may be appropriate where buses have to share general traffic lanes when they pass stopped buses.

#### **A-1.1.4. Outlying Stops/Stations**

The number of bus berths that should be provided at outlying bus stops can also be estimated based upon random arrival assumptions. Table A-5 gives the number of berths that should be provided based on the Poisson distribution and allowing only a 5 percent change that the bus bays will overload.

Emergent guidelines are as follows:

- Passenger service times of 20 seconds or less: one bus berth per 60 peak hour buses (arterial street condition).
- Passenger service times of 30 to 50 seconds: one bus berth per 30 peak hour buses.
- Passenger service times of more than 50 seconds: two berths for every 60 peak hour buses.

## **APPENDIX A**

### **REFERENCES**

1. Levinson, H.S., C.L. Adams, and W.F. Hoey. *Bus Use of Highways: Planning and Design Guidelines*, NCHRP Report 155. Transportation Research Board, National Research Council, Washington, D.C., 1975.
2. Special Report 209: Highway Capacity Manual, Transportation Research Board, National Research Council, Washington, D.C., 1985 (1994 and 1997 and 2000 updates).
3. TCRP A-15A, Update of the First Edition Transit Capacity and Quality of Service Manual, Second Draft, Kittleson Associates, November 2002.

**TABLE A-1**

**VALUES OF PERCENT FAILURE AND ASSOCIATED ONE TAIL NORMAL VARIATION**

<u>Failure (%)</u>	<u>Z<sub>a</sub></u>
1.0	2.330
2.5	1.960
5.0	1.645
7.5	1.440
10.0	1.280
15.0	1.040
20.0	0.840
25.0	0.675
30.0	0.525
50.0	0.000

**TABLE A-2**

**UNINTERRUPTED FLOW**

Failure Rate	Average Dwell Time, Seconds						
	10	20	30	40	50	60	
1.00%	92	57	41	32	27	23	
2.50%	98	62	45	35	29	25	
5.00%	103	66	48	38	31	27	
7.50%	107	69	51	40	33	28	
10%	110	71	56	45	37	32	
15%	145	76	56	45	37	32	
20%	120	78	60	48	40	34	
25%	24	84	63	55	42	36	
30%	128	87	66	53	45	38	
50%	144	103	80	65	55	48	

**SIGNALIZED WITH GREEN/CYCLE = 0.5**

Failure Rate	Average Dwell Time, Seconds						
	10	20	30	40	50	60	
1.00%	53	34	25	20	16	14	
2.50%	57	37	28	22	18	16	
5.00%	60	40	30	24	20	17	
7.50%	63	43	32	26	27	19	
10%	65	45	34	27	23	20	
15%	69	48	37	30	25	22	
20%	72	51	40	33	28	24	
25%	75	54	43	35	30	26	
30%	78	58	46	38	32	28	
50%	90	72	60	51	45	40	

**TABLE A-3**  
**EFFICIENCY OF MULTIPLE BERTHS**

**Effective Berth Factor,  $N_b$**

<b>Berth No.</b>	<b>On-line Stops</b>	<b>Off-line Stops</b>
<b>1</b>	<b>1.00</b>	<b>1</b>
<b>2</b>	<b>1.75</b>	<b>1.85</b>
<b>3</b>	<b>2.45</b>	<b>2.60</b>
<b>4</b>	<b>2.65</b>	<b>3.25</b>
<b>5</b>	<b>2.75</b>	<b>3.75</b>

**SOURCES:**

1. Special Report 209: Highway Capacity Manual, Transportation Research Board, National Research Council, Washington, D.C., 1985 (1994 and 1997 and 2000 updates).
2. Operational Analysis of Bus Lanes on Arterials – Application and Refinement, Research Results Digest – September 2000, Number 38, Transit Cooperative Research Program, Transportation Research Board, National Research Council, Washington, DC.

**TABLE A-4  
TYPICAL SERVICE VOLUMES**

<b>BUS/FARE COLLECTION</b>	<b>Arterial 50% Green/Cycle</b>						<b>Grade Separated Busway</b>			
	<u>Regular</u>			<u>Articulated</u>			<u>Regular</u>		<u>Articulated</u>	
Type of Bus	1	2	2	2	2	3	1	2	2	3
Door Channels Available for Boarding	On	Off	Off	On	Off	Off	Off	Off	Off	Off
Fare Collection	Vehicle			Vehicle			Vehicle		Vehicle	
Service Time Per Passenger Door <sup>(1)(2)</sup>	3.5	2.5	2	2.5	2	1.5	2.5	2	2	1.5
Passengers Boarding/Bus	25	15	15	20	20	20	15	15	20	20
<b>DWELL TIME (Seconds)</b>										
Passenger Boarding Time	52	38	30	50	40	30	38	30	40	30
Adjustment Factor for Random Variations <sup>(3)</sup>	0.905	0.905	0.905	0.905	0.905	0.905	1.405	1.405	1.405	1.405
Effective Dwell Time	47	34	27	45	36	27	53	42	56	42
Clearance Time	15	15	15	15	15	15	15	15	15	15
Effective Dwell Time, Plus Clearance	62	49	42	60	51	42	68	50	71	57
<b>BUSES &amp; PASSENGERS/HOUR</b>										
Buses/Berth/Hour	29	37	43	30	35	45	53	63	51	63
Passengers/Berth/Hour	435	550	645	600	705	855	795	945	1020	1260
Effective berths	2.5	2.5	2.5	2.5	2.5	2.5	2.5	2.5	2.5	2.5
Passengers/Berth/Hour	1090	1375	1610	1500	1765	2145	1990	2360	2550	3150
<b>PASSENGERS PER HOUR PAST MAXIMUM LOAD SECTION</b>										
25% Board at Busiest Station	4360	5500	6440	6000	7060	8570	7960	9440	10200	12600
50% Board at Busiest Station	2180	2750	3220	3000	3530	4290	3980	4720	5100	6300

1. Assumes Loading Conditions Govern
2. Service Time/Door Adjusted to reflect use of multiple doors, e.g. from 1 to 2 doors gives a 0.7 value
3. Effective Service Time =  $[1+(.675)(.6)]$  or 1.455 for uninterrupted flow, and  $[.5+.675(.6)]$  or .905 for a g/c of 0.5 for interrupted flow to account for likely variations per hour applied to passenger boarding
4. Capacity equals 1800 divided by effective dwell plus clearance for signalized intersections (g/c = 0.5) and 3600 divided by effective dwell plus clearance time uninterrupted flow (g/c = 1.0)

**TABLEA-5**  
**BERTH REQUIREMENTS AT BUS STOPS**  
**(Outlying Locations)**

Peak Hour Bus Flow (Bus/Hr.)	Headway (Min.)	Number of Berths When Service Time at Stop is					
		10 Sec.	20 Sec.	30 Sec.	40 Sec.	50 Sec.	60 Sec.
15	4	1	1	1	1	1	1
30	2	1	1	1	1	1	1
45		1	1	2	2	2	2
60	1	1	1	2	2	2	2
75		1	2	2	3	3	3
90		1	2	3	3	4	4
105		1	2	3	3	4	4
120	1/2	1	2	3	3	5	5
150		2	3	3	4	5	5
180	1/3	2	3	4	5	6	6

NOTE: 95% probability that number of berths will not be overloaded; assumes a Poisson Distribution of Bus Arrivals.



## **APPENDIX B**

### **PEDESTRIAN AND LIGHTING GUIDELINES**

## **APPENDIX B**

### **PEDESTRIAN AND LIGHTING GUIDELINES**

This appendix contains detailed guidelines for (1) estimating pedestrian capacities and service levels, and for (2) establishing lighting levels.

Pedestrian levels of service for walkways, stairways, and waiting areas are given in Table B-1. Pedestrian ramps can achieve about the same capacities as walkways. A Level of Service D or better should be used for walkways and stairways. To meet ADA requirements, at least 10 square feet per person should be provided for pedestrian waiting and queuing areas; this corresponds to Service Level C.

Reported capacities for doorways and escalators are given in Table B-2.

Observed average fare gate headways and capacities are shown in Table B-3.

Recommend lighting levels (luminance in foot candles are set forth in Table B-4). They can augment municipal codes as appropriate.

**TABLE B-1**  
**PEDESTRIAN LEVELS OF SERVICE**

	L O S					
	A	B	C	D	E	F
WALKWAY						
SQ FT/PERSON	≥35	25-35	15-25	10-15	5-10	<5
PED/FT/MIN	0-7	7-10	10-15	15-20	20-25	VARIABLE
STAIRWAYS						
SQ FT/PERSON	≥20	15-20	10-15	7-10	4-7	<4
PED/FT/MIN	≤5	5-7	7-10	10-13	13-17	VARIABLE
QUEUING AND WAITING AREAS						
SQ FT/PERSON	>13	10-13	7-10	3-7	2-3	<2
AVG. INTERPERSON SPACING	>4.0	3.5-4	3.0-3.5	2.0-3.0	≤2.0	VARIABLE

SOURCE: Adapted from Section 7, Kittleson Associates, Inc.  
Transit Capacity and Quality of Service Manual, Second Edition Draft, October 10, 2002  
 Transportation Research Board/Fruin, J. Pedestrian Planning and Design, Revised Edition, Elevator World, 1987

**TABLE B-1**  
**PEDESTRIAN LEVELS OF SERVICE**

	ALT. FORM	
	SQ FT/PED	PED/FT/MIN
WALKWAYS		
LOS		
A	≥35	0-7
B	25-35	7-10
C	15-25	10-15
D	10-15	15-20
E	5-10	20-25
F	<5	VARIABLE
STAIRWAYS		
LOS		
A	≥20	≥5
B	15-20	5-7
C	10-15	7-10
D	7-10	19-13
E	4-7	13-17
F	<4	VARIABLE
QUEUING AND WAITING AREAS		
LOS		AVERAGE INTERPERSONAL SPACING
A	>13	4.0
B	10-13	3.5-4.0
C	7-10	3.0-3.5
D	3-7	2.0-3.0
E	2-3	≥2.0
F	<2	VARIABLE

**TABLE B-2**  
**DOORWAY AND ESCALATOR CAPACITIES**

DOORWAYS TYPE OF ENTRANCE ENTRANCE	SINGLE CHANNEL		
	OBSERVED AVERAGE HEADWAY SECONDS	EQUIVALENT PEDESTRIAN VOLUME PER MINUTE	PER HOUR
FREE SWINGING	1.0 – 1.5	40 – 60	2400 - 3600
REVOLVING, PER DIRECTION	1.7 – 2.4	25 – 35	1500 - 2100

ESCALATORS		INCLINE SPEED FT/MIN	NOMINAL CAPACITY	
	WIDTH AT TREAD (IN)		PED/MIN	PED/HR
SINGLE WIDTH	24	90	34	2040
		120	45	2700
DOUBLE WIDTH	40	90	68	4080
		120	90	5400

NOTE: For planning purposes. Should not be used to determine means of egress.

**TABLE B-3**  
**OBSERVED AVERAGE FARE GATE HEADWAYS AND CAPACITIES**

EQUIVALENT PEDESTRIAN TYPE OF ENTRANCE (PED/MIN)	OBSERVED AVERAGE	
	HEADWAY SECONDS	VOLUME
Free admission	1.0-1.5	40-60
Ticket collector	1.7-2.4	25-35
Single-slot coin- or token-operated	1.2-2.4	25-50
Double-slot coin-operated	2.5-4.0	15-25
Card reader (various types)	1.5-4.0	25-40
High entrance/exit turnstile	3.0	20
High exit turnstile	2.1	28
Exit gate, 3.0 ft (0.9 m) wide	0.8	75
Exit gate, 4.0 ft (1.2 m) wide	0.6	100
Exit gate, 5.0 ft (1.5 m) wide	0.5	125

SOURCE: Fruin J., Pedestrian Planning and Design, Revised Edition, Elevator World, Mobile, AL, 1987.

**TABLE B-4**

**RECOMMENDED LIGHTING LEVELS (ILLUMINANCE IN FOOT CANDLES)**

	<u>FOOT CANDLES</u>
STATION PLATFORMS AND SHELTERS	
OPEN PLATFORM	5
LOADING PLATFORM	
UNDER CANOPY	10-15
TICKETING AREA – TURNSTILES	20
PASSAGE WAYS	20
FARE COLLECTION BOOTHS	100
CONCESSIONS AND VENDING MACHINE AREAS	30
STAIRS AND ESCALATORS	20
WASHROOMS	30
PARKING AREAS – LOTS	
PASSENGER DROP-OFF	3-5
PARKING LOTS	1-2
PARKING FOR HANDICAPPED	3-4
ENTRANCES AND EXITS	3-4
BUS LOOPS, RAMPS & ACCESS HEADWAYS	1.0-1.5
PARKING AREAS – GARAGES	
ENTRANCE AND EXITS	DAY 50, NIGHT 5
TRAFFIC LANES/RAMPS	10
PARKING AREAS	3-5
STAIRS AND ESCALATORS	20
WALKWAYS	
SIDEWALKS	0.5-2.0
WALKWAYS DISTANCE FROM ROADWAYS	0.5
PEDESTRIAN TUNNEL	4-5
UNIFORM VALUES (EXCEPT UNDER THE PASSENGER CANOPY) SHALL NOT EXCEED THE FOLLOWING VALUES:	
AVERAGE TO MINIMUM	2.5 TO 1
MAXIMUM TO MINIMUM	5 TO 1

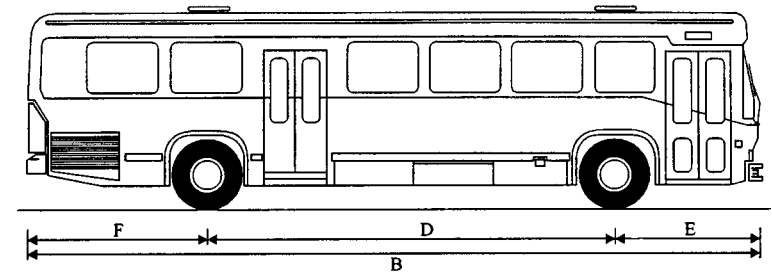
- SOURCE:
1. Design Criteria for METRO Park & Ride and Transit Facilities, Metropolitan Transit Authority, Houston, November 2000.
  2. Illuminating Engineering Society of North America – Value of Public Roadway Lighting, New York Report IES-CP31-1987.
  3. Guide for the Design of Park-and-Ride Facilities, AASHTO, Washington, D.C., 1994.

APPENDIX C

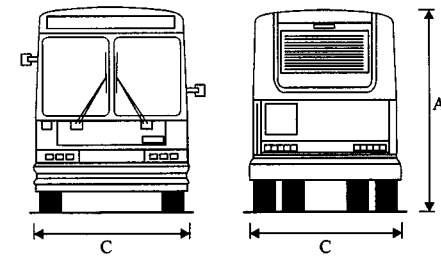
DESIGN VEHICLE CHARACTERISTICS

LIST OF FIGURES

- C-1 DESIGN VEHICLE CHARACTERISTICS FOR TYPICAL 40 FT BUS
- C-2 DESIGN VEHICLE CHARACTERISTICS FOR TYPICAL 45 FT BUS
- C-3 DESIGN VEHICLE CHARACTERISTICS FOR TYPICAL 60 FT BUS
- C-4 US CUSTOMARY DESIGN VEHICLE SPECIFICATIONS
- C-5 TURNING RADII FOR DESIGN VEHICLES
- C-6 TURNING RADII FOR TYPICAL 40 FT BUS
- C-7 TURNING RADII FOR TYPICAL 45 FT BUS
- C-8 TURNING RADII FOR TYPICAL 40 FT DUAL-DOOR BUS
- C-9 TURNING RADII FOR TYPICAL 60 FT BUS



ITEM	
A Overall Height	3.0 m (9.9 ft) - 3.4 m (11.1 ft) *
B Overall Length	12.1 m (40 ft)
C Overall Width	2.5 m (8.2 ft) - 2.6 m (8.5 ft) *
D Wheel Base	7.2 m (23.7 ft) - 7.6 m (24.9 ft) *
E Front Axle to Bumper	2.1 m (7.2 ft)
F Rear Axle to Bumper	2.4 m (9.3 ft)

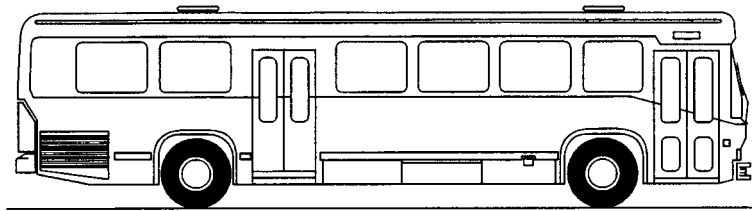


NET/GROSS VEHICLE WEIGHT **	
Front Axle	3,370/5,440 kg (7,420/11,980 lbs)
Rear Axle	8,200/11,200 kg (18,060/24,660 lbs)
Seating Capacity	46 - 51 *
Standing Capacity	20 - 25 *

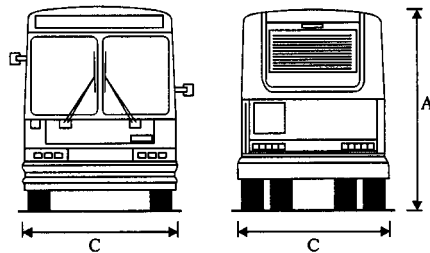
NOTES  
 \* Varies for different types of 12.1 m (40 ft) buses  
 \*\* Net Weight is "Road Ready" Without Passengers  
 Gross Includes Passengers

(Source: NCHRP 414 HOV System Manual, Texas Transportation Institute, Parsons Brinckerhoff, Oracle and Douglas Pacific Rim Association, TRB, National Research Council, Washington, D.C., 1998.)

Design Vehicle Characteristics for Typical 40 Ft Bus  
 Figure C1



ITEM	
A Overall Height	3.7 m (12.2 ft)
B Overall Length	13.7 m (45 ft)
C Overall Width	2.6 m (8.5 ft)
D Wheel Base	6.9 m (22.9 ft)



NET/GROSS VEHICLE WEIGHT **	
17,326/22,777 kg (38,150/50,150 lbs)	

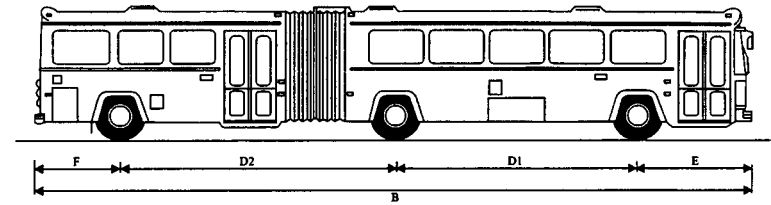
Seating Capacity	50 *
Standing Capacity	28 *

**NOTES**

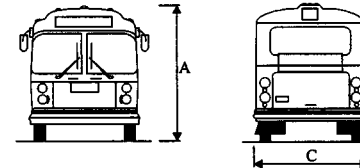
- \* Varies for different types of 13.7 m (45 ft) buses
- \*\* Net Weight is "Road Ready" Without Passengers  
Gross Includes Passengers

(Source: NCHRP 414 HOV System Manual, Texas Transportation Institute, Parsons Brinckerhoff, Oracle and Douglas Pacific Rim Association. TRB, National Research Council, Washington, D.C., 1998.)

Design Vehicle Characteristics for Typical 45 Ft Bus  
Figure C2



ITEM	
A Overall Height	3.2 m (10.2 ft)
B Overall Length	18.3 m (60 ft)
C Overall Width	2.6 m (8.5 ft)
D1 Wheel Base - Front	5.3 m (17.5 ft) - 5.7 m (18.6 ft)*
D2 Wheel Base - Rear	7.1 m (23.3 ft) - 7.4 m (24.2 ft)*
E Front Axle to Bumper	2.6 m (8.5 ft)
F Rear Axle to Bumper	2.9 m (8.7 ft)



NET/GROSS VEHICLE WEIGHT **	
Front Axle	5,360/7,450 kg (11,800/16,420 lbs)
Rear Axle	5,510/7,420 kg (12,130/16,420 lbs)
Center Axle	6,800/11,010 kg (14,970/24,250 lbs)

MAXIMUM BEND ANGLE	
Horizontal	± 36 deg
Vertical	± 11 deg

Seating Capacity	70 - 76 *
Standing Capacity	38 *

**NOTES**

- \* Varies for different types of articulated buses
- \*\* Net Weight is "Road Ready" Without Passengers  
Gross Includes Passengers

(Source: NCHRP 414 HOV System Manual, Texas Transportation Institute, Parsons Brinckerhoff, Oracle and Douglas Pacific Rim Association. TRB, National Research Council, Washington, D.C., 1998.)

Design Vehicle Characteristics for Typical 60 Ft Bus  
Figure C3

US Customary

Design Vehicle Type	Symbol	Dimensions (ft)										Typical Kingpin to Center of Rear Axle	
		Overall			Overhang								
		Height	Width	Length	Front	Rear	WB <sub>1</sub>	WB <sub>2</sub>	S	T	WB <sub>3</sub>		WB <sub>4</sub>
Passenger Car	P	4.25	7	19	3	5	11	—	—	—	—	—	—
Single Unit Truck	SU	11-13.5	8.0	30	4	6	20	—	—	—	—	—	—
<b>Buses</b>													
Inter-city Bus (Motor Coaches)	BUS-40	12.0	8.5	40	6	6.3 <sup>a</sup>	24	3.7	—	—	—	—	—
	BUS-45	12.0	8.5	45	6	8.5 <sup>a</sup>	26.5	4.0	—	—	—	—	—
City Transit Bus	CITY-BUS	10.5	8.5	40	7	8	25	—	—	—	—	—	—
Conventional School Bus (65 pass)	S-BUS 36	10.5	8.0	35.8	2.5	12	21.3	—	—	—	—	—	—
Large School Bus (84 pass)	S-BUS 40	10.5	8.0	40	7	13	20	—	—	—	—	—	—
Articulated Bus	A-BUS	11	8.5	60	8.6	10	22.0	19.4	6.2 <sup>a</sup>	13.2 <sup>a</sup>	—	—	—
<b>Trucks</b>													
Intermediate Semitrailer	WB-40	13.5	8.0	45.5	3	2.5 <sup>a</sup>	12.5	27.5	—	—	—	—	27.5
Intermediate Semitrailer	WB-50	13.5	8.5	55	3	2 <sup>a</sup>	14.6	35.4	—	—	—	—	37.5
Interstate Semitrailer	WB-62 <sup>b</sup>	13.5	8.5	68.5	4	2.5 <sup>a</sup>	21.6	40.4	—	—	—	—	42.5
Interstate Semitrailer	WB-65 <sup>c</sup> or WB-67	13.5	8.5	73.5	4	4.5-2.5 <sup>d</sup>	21.6	43.4-45.4	—	—	—	—	45.5-47.5
"Double-Bottom"-Semitrailer/Trailer	WB-67D	13.5	8.5	73.3	2.33	3	11.0	23.0	3.0 <sup>e</sup>	7.0 <sup>e</sup>	23.0	—	23.0
Triple-Semitrailer/Trailers	WB-100T	13.5	8.5	104.8	2.33	3	11.0	22.5	3.0 <sup>e</sup>	7.0 <sup>e</sup>	23.0	23.0	23.0
Turnpike Double-Semitrailer/Trailer	WB-109D <sup>f</sup>	13.5	8.5	114	2.33	2.5 <sup>a</sup>	14.3	39.9	2.5 <sup>a</sup>	10.0 <sup>g</sup>	44.5	—	42.5
<b>Recreational Vehicles</b>													
Motor Home	MH	12	8	30	4	6	20	—	—	—	—	—	—
Car and Camper Trailer	P/T	10	8	48.7	3	10	11	—	5	19	—	—	—
Car and Boat Trailer	P/B	—	8	42	3	8	11	—	5	15	—	—	—
Motor Home and Boat Trailer	MHB	12	8	53	4	8	20	—	6	15	—	—	—
Farm Tractor <sup>h</sup>	TR	10	8-10	16 <sup>i</sup>	—	—	10	9	3	6.5	—	—	—

- <sup>a</sup> = Design vehicle with 48 ft trailer as adopted in 1982 Surface Transportation Assistance Act (STAA).
- <sup>aa</sup> = Design vehicle with 53 ft trailer as grandfathered in with 1982 Surface Transportation Assistance Act (STAA).
- <sup>b</sup> = Combined dimension is 19.4 ft and articulating section as 4 ft wide.
- <sup>c</sup> = Combined dimension is typically 10 ft.
- <sup>d</sup> = Combined dimension is typically 10 ft.
- <sup>e</sup> = This is overhang from the back axle of the tandem axle assembly.
- <sup>f</sup> = Dimensions are for a 150-200 hp tractor excluding any wagon length.
- <sup>g</sup> = To obtain the total length of tractor and one wagon, add 18.5 ft to tractor length. Wagon length is measured from front of drawbar to rear of wagon, and drawbar is 6.5 ft long.
  - WB<sub>1</sub>, WB<sub>2</sub>, and WB<sub>3</sub> are the effective vehicle wheelbases, or distances between axle groups, starting at the front and working towards the back of each unit.
  - S is the distance from the rear effective axle to the hitch point or point of articulation.
  - T is the distance from the hitch point or point of articulation measured back to the center of the next axle or center of tandem axle assembly.
- <sup>h</sup> =
- <sup>i</sup> =

(Source: A Policy on Geometric Design of Highways and Streets 2001. American Association of State Highway and Transportation Officials, Washington, D.C., 2001.)

US Customary Design Vehicle Specifications  
Figure C4

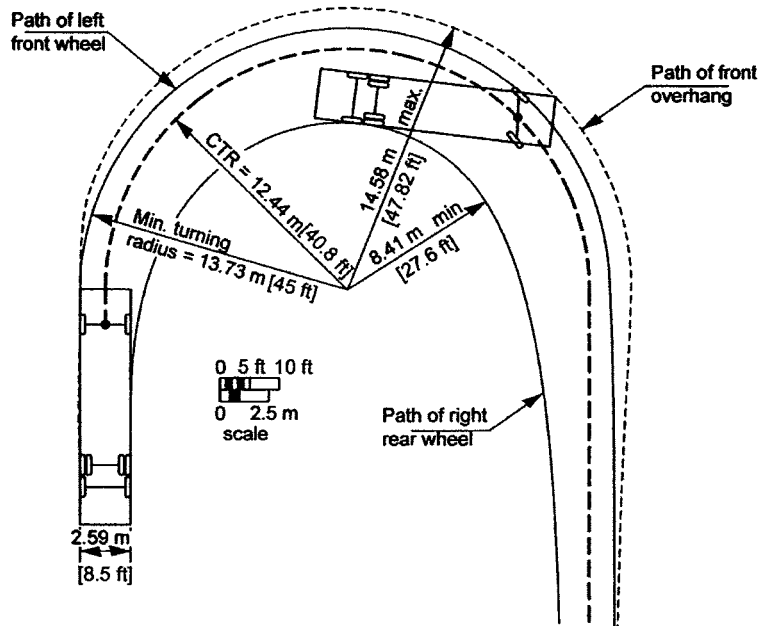
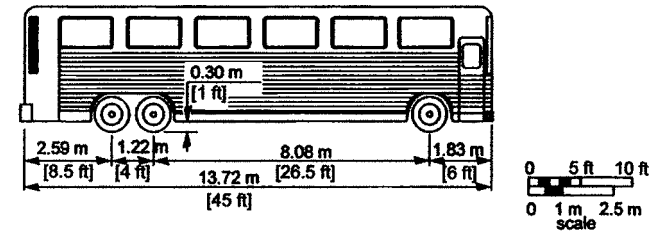
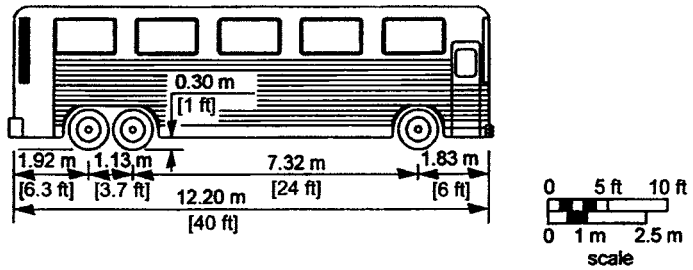
US Customary

Design Vehicle Type	Passenger Car	Single Unit Truck	Inter-city Bus (Motor Coach)		City Transit Bus	Conventional School Bus (65 pass.)	Large <sup>2</sup> School Bus (84 pass.)	Articulated Bus	Intermediate Semi-trailer	Intermediate Semi-trailer
Symbol	P	SU	BUS-40	BUS-45	CITY-BUS	S-BUS36	S-BUS40	A-BUS	WB-40	WB-50
Minimum Design Turning Radius (ft)	24	42	45	45	42.0	38.9	39.4	39.8	40	45
Center-line <sup>1</sup> Turning Radius (CTR)	21	38	40.8	40.8	37.8	34.9	35.4	35.5	36	41
Minimum Inside Radius (ft)	14.4	28.3	27.6	25.5	24.5	23.8	25.4	21.3	19.3	17.0
Design Vehicle Type	Interstate Semi-trailer		"Double Bottom" Combination	Triple Semi-trailer/trailers	Turnpike Double Semi-trailer/trailer	Motor Home	Car and Camper Trailer	Car and Boat Trailer	Motor Home and Boat Trailer	Farm <sup>3</sup> Tractor w/One Wagon
Symbol	WB-62 <sup>*</sup>	WB-65 <sup>**</sup> or WB-67	WB-67D	WB-100T	WB-109D <sup>*</sup>	MH	P/T	P/B	MHB	TRW
Minimum Design Turning Radius (m)	45	45	45	45	60	40	33	24	50	18
Center-line <sup>1</sup> Turning Radius (CTR)	41	41	41	41	56	36	30	21	46	14
Minimum Inside Radius (m)	7.9	4.4	19.3	9.9	14.9	25.9	17.4	8.0	35.1	10.5

- <sup>\*</sup> = Design vehicle with 48 ft trailer as adopted in 1982 Surface Transportation Assistance Act (STAA).
- <sup>\*\*</sup> = Design vehicle with 53 ft trailer as grandfathered in with 1982 Surface Transportation Assistance Act (STAA).
- <sup>1</sup> = The turning radius assumed by a designer when investigating possible turning paths and is set at the centerline of the front axle of a vehicle. If the minimum turning path is assumed, the CTR approximately equals the minimum design turning radius minus one-half the front width of the vehicle.
- <sup>2</sup> = School buses are manufactured from 42 passenger to 84 passenger sizes. This corresponds to wheelbase lengths of 132 in to 237 in, respectively. For these different sizes, the minimum design turning radii vary from 28.8 ft to 39.4 ft and the minimum inside radii vary from 14.0 ft to 25.4 ft.
- <sup>3</sup> = Turning radius is for 150-200 hp tractor with one 18.5 ft long wagon attached to hitch point. Front wheel drive is disengaged and without brakes being applied.

(Source: A Policy on Geometric Design of Highways and Streets 2001. American Association of State Highway and Transportation Officials, Washington, D.C., 2001.)

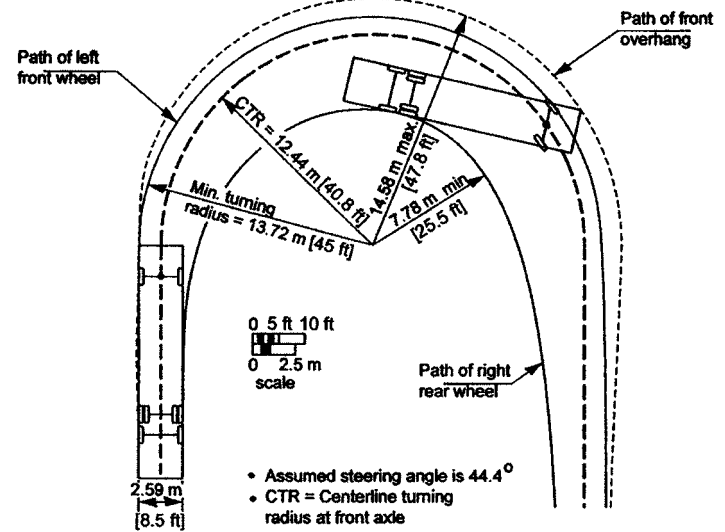
Turning Radii for Design Vehicles  
Figure C5



- Assumed steering angle is 38.7°
- CTR = Centerline turning radius at front axle

(Source: A Policy on Geometric Design of Highways and Streets 2001, American Association of State Highway and Transportation Officials, Washington, D.C., 2001.)

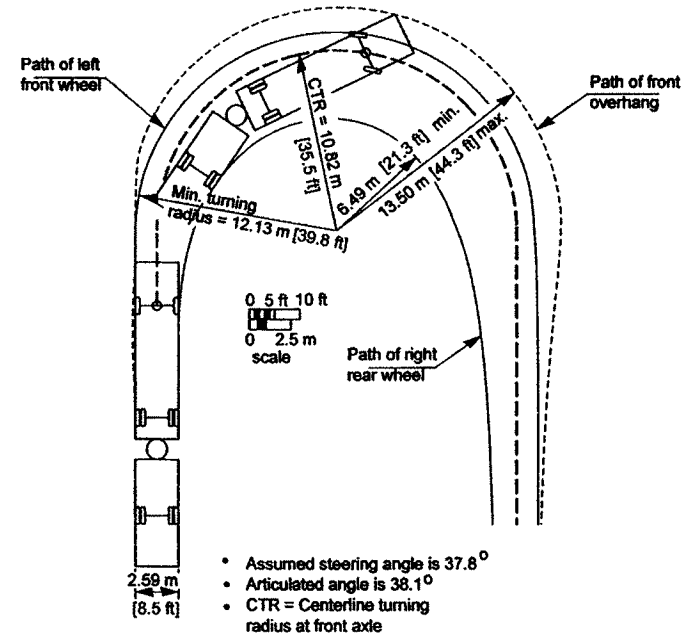
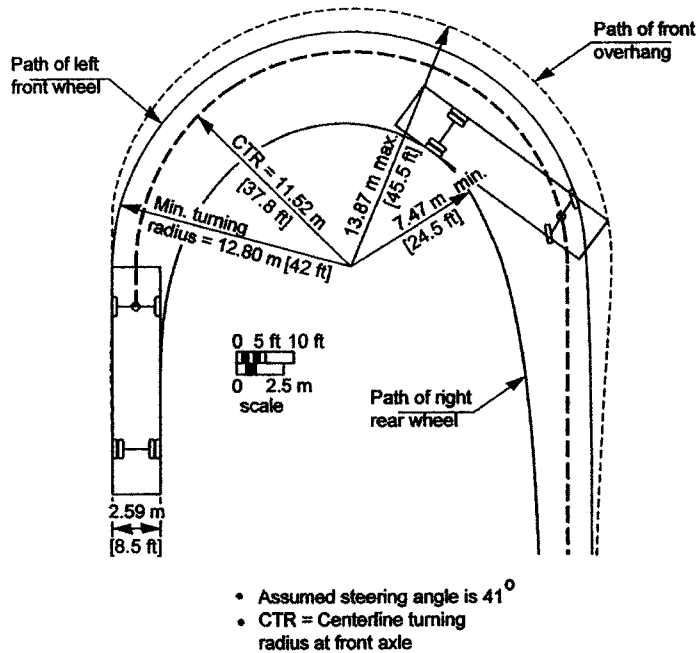
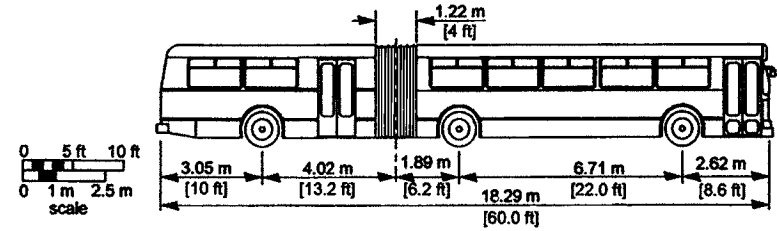
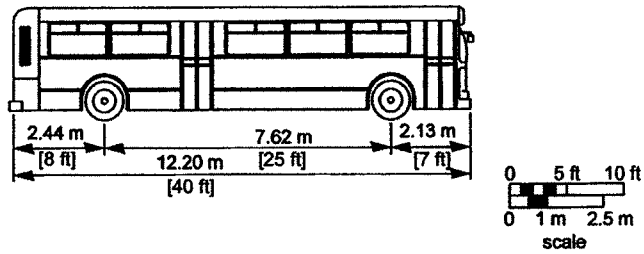
Turning Radii for Typical 40 Ft Bus  
Figure C6



(Source: A Policy on Geometric Design of Highways and Streets 2001, American Association of State Highway and Transportation Officials, Washington, D.C., 2001.)

Turning Radii for Typical 45 Ft Bus  
Figure C7





(Source: A Policy on Geometric Design of Highways and Streets 2001. American Association of State Highway and Transportation Officials, Washington, D.C., 2001.)

Turning Radii for Typical 40 Ft Dual-Door Bus  
Figure C8

Turning Radii for Typical 60 Ft Bus  
Figure C9

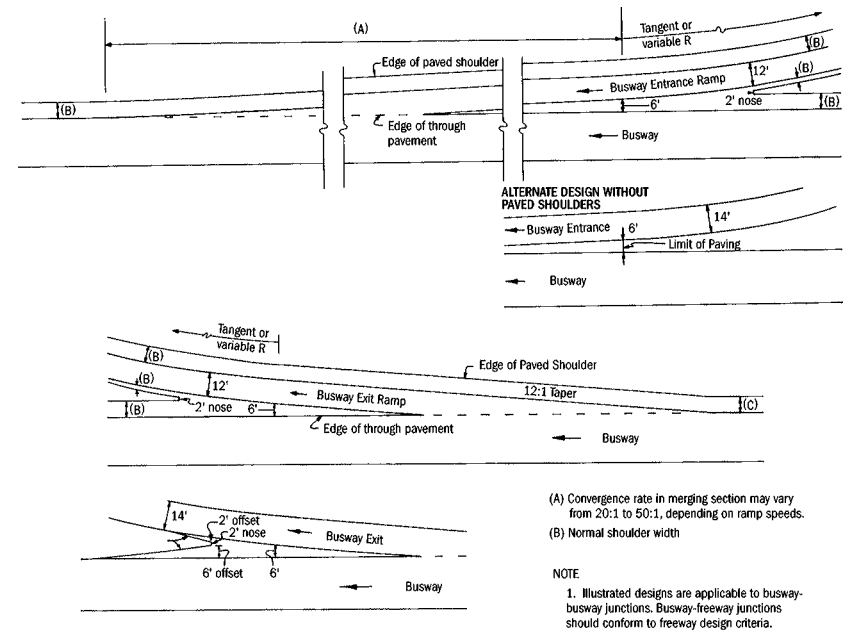
**APPENDIX D**  
**DETAILS OF ACCESS POINT DESIGN**

**LIST OF FIGURES**

**D-1 ENTRANCE AND EXIT RAMP DIMENSIONS**

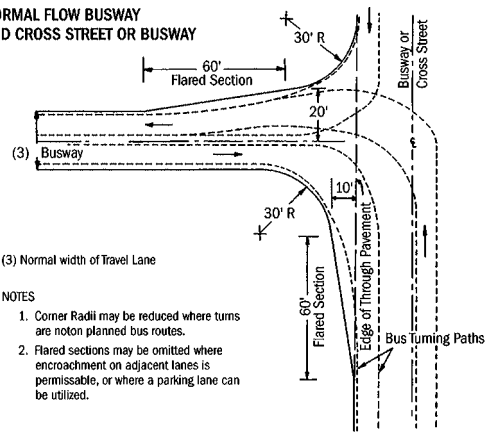
**D-2 INTERSECTION DESIGN DIMENSIONS FOR BUSWAYS**

Source: Levinson H.S., et al, NCHRP Report 155, Bus Use of Highways Planning and Design Guidelines, Transportation Research Board, National Research Council, Washington D.C., 1975.

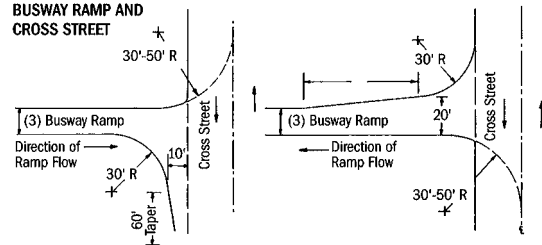


Entrance and Exit Ramp Dimensions  
Figure D1

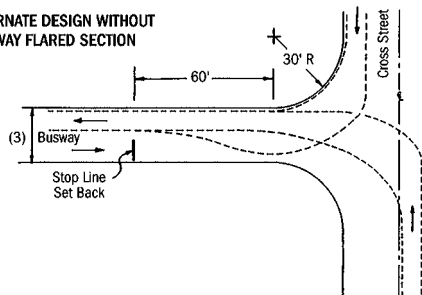
**NORMAL FLOW BUSWAY  
AND CROSS STREET OR BUSWAY**



**BUSWAY RAMP AND  
CROSS STREET**



**ALTERNATE DESIGN WITHOUT  
BUSWAY FLARED SECTION**



(Source: Levinson, H.S., et al, NCHRP Report 155, *Bus Use of Highways Planning and Design Guidelines*, Transportation Research Board, National Research Council, Washington, D.C., 1975.)

Intersection Design Dimensions for Busways  
Figure D2

## APPENDIX E

### BRT VEHICLE TECHNOLOGY DETAILS

E-1.	INTRODUCTION .....	E-1
E-2.	ONBOARD (NON-PROPULSION) ELECTRONICS .....	E-1
E-2.1.	Intelligent Transportation Systems .....	E-1
E-2.2.	Communications .....	E-2
E-2.3.	Fare Collection.....	E-3
E-2.4.	Passenger Security.....	E-4
E-3.	CHASSIS AND SUSPENSION .....	E-5
E-3.1.	Body Features .....	E-8
E-4.	AUXILIARIES .....	E-12
E-5.	TOTAL SYSTEM COSTS .....	E-13
E-6.	CONCLUSION.....	E-14

## APPENDIX E

### BRT VEHICLE TECHNOLOGY DETAILS

#### E-1. INTRODUCTION

This appendix contains further details of the major systems and subsystems that comprise modern BRT vehicles. It covers on-board electronics, chassis and suspension, body features, auxiliaries, and examples of BRT system and vehicle costs.

#### E-2. ONBOARD (NON-PROPULSION) ELECTRONICS

Buses are increasingly being equipped with input/output multiplexers. The electronic communications and control devices reduce the amount of wiring required, allow monitoring of subsystem status, and facilitate rapid diagnosis of faults. These are not unique to vehicles in BRT service, but for specialized BRT vehicles, they can be expected to be connected to a larger number components and subsystems due to the increased complexity of the vehicle design. These might include two or more drive motors, computerized engine controls, advanced active suspension (keeps vehicles level in turns for comfort and safety), Intelligent Transportation Systems (ITS), air-conditioning and other auxiliaries.

The multiplexer has a port which further allows a skilled technician to use a laptop personal computer to identify more precisely where faults are within the bus. This can greatly reduce the time needed for troubleshooting. In turn, electronic subsystems can be installed in the bus in a modular fashion, a technique long used in aircraft. The faulty module is removed and quickly replaced to reduce the downtime of the vehicle.

##### E-2.1. Intelligent Transportation Systems

BRT vehicles, whether buses or specialized vehicles, must be equipped with a variety of Intelligent Transportation Systems (ITS). These are not necessarily unique to BRT vehicles, but are required for the special image and role these vehicles play within a transit network.

The centerpiece of ITS is an Automatic Vehicle Location (AVL) system. It provides the information needed for real-time control of operations and for real-time passenger information. Furthermore, it provides a time and location stamp for all other events monitored and measurements taken by the onboard electronics. The predominant technology in use is Global Positioning Satellite (GPS), supplemented by an odometer reading so that a backup exists should the GPS skip one or more of its periodic readings. This information is periodically sent to the dispatcher workstation and on to websites via a data radio.

BRT vehicles should have ADA features such as visual and audio stop annunciation, similar to buses in regular service. AVL systems may also provide additional messages about connecting routes. The annunciation and messaging can be fully automatic due to a link with the AVL system. Outside destination signs can also be linked to the AVL system. Internal visual information can be provided, either through horizontally moving messages through multiple-row electronic signs, or through video screens. The increasing compactness of flat panel video screens and decreasing price will probably lead to their being favored over time.

### **E-2.2. Communications**

The communication interface from the operator to the dispatcher is through a Mobile Data Terminal (MDT). It will have a display that typically notifies when there are

incoming messages, acknowledges receipt of outgoing messages, provides operational assistance such as schedule adherence information, and vehicle condition information. It can send information to the dispatcher or maintenance facility from any other equipment connected to a multiplexer, either routinely or on an exception basis. The latter has the advantage that the radio message traffic is much less.

The default communication method is usually two-way digital messaging. However, a voice radio is also used as a backup and for communications that can not be done with preset (canned) message buttons. Data not transmitted over the data radio during the day can be stored until the end of the day for downloading. The technique can be through a disk medium or a cable connection, but these can be impractical for large fleets. The technique thus gaining popularity is a weak radio. This technique is known as Dedicated Short Range Communications (DSRC).

BRT operations will almost always involve some degree of transit priority at intersections, which typically requires additional local communications to report the presence of the bus nearing an intersection, such as an optical signal to a traffic signal controller, an infrared signal to a signpost along the roadside, or DSRC. Such subsystems must be integrated into the AVL system.

### **E-2.3. Fare Collection**

Smart card readers, either contacting or contact-less, are also very likely to be present on buses used in BRT operations. These are for the convenience of passengers, and most importantly, to speed operations by relieving the operator of fare responsibility to the maximum extent possible and by reducing time passengers spend blocking doorways. The “Smart Farebox” also can accept cash, tokens or other non-smart card fare

media. Smart fare systems can receive a time and location stamp from the AVL system, if desired. This data can be sent either over the course of the day or downloaded at the end. Photo E-1 shows a WMATA farebox with the convenience of both a magnetic stripe card and a smart card reader-writer.

Fare collection is one way to provide passenger count information, but typically only provides boardings (unless passengers are required to re-read their smart card upon alighting). Automatic Passenger Counters (APCs) in the doorways provide full on and off count capability. The number of boardings and alightings is time and location stamped through a link with the AVL system. Once again, the data can be sent over the course of the day or downloaded at the end. In an interesting application, at least one agency (Paris RATP) uses both real-time boarding counts from contact-less card readers and from the APCs. The comparison of the two can detect fare evasion.

#### **E-2.4. Passenger Security**

There are a variety of security features which can be installed and are likely to see use in BRT operations, since safety and security are central to its image. Vehicles equipped with AVL can have a covert alarm that the operator can activate. A few agencies have also installed covert microphones, which transmit over the voice radio to allow the dispatch center or police to determine the nature of the emergency. Cameras can store images on board for later use as evidence. Their presence alone can act as a deterrent.

There is also at least one product available that can transmit photos over the digital radio, but its current popularity is limited, since it would require a long

transmission time. “Near real-time” transmission of photos as well as video will increase when high-transmission-rate data radios become widely available.

Like typical transit buses, BRT vehicles can have several subsystems requiring “logging in” or which need to be initialized by the operator. The AVL system, the smart farebox, the destination signs, the stop annunciator, etc. may all be provided by different vendors, installed at different times, each requiring separate procedures. There may also be a clutter of equipment and bracketry, perhaps with more than one MDT, surrounding the operator’s seat. Furthermore, the vehicle may have additional multiplexers, GPS units, and other duplicative devices retrofitted.

Standards being developed within the North American ITS community should reduce the problem with duplicative devices. At least one major European bus manufacturer is already addressing this issue (Volvo Mobility Systems, 2001). Its vehicles will come standard with all of the interfaces for a wide variety of ITS subsystems and will install those selected at the time of purchase on the assembly line instead of as a retrofit. A multifunctional MDT will be built into the driver console. It can serve as a simultaneous login for multiple devices, for AVL-related communications, for vehicle condition reporting, and other functions. This will likely be standard practice over time, since it simplifies the bus specification, manufacture, and the tasks the bus operator must perform.

#### **E-3. CHASSIS AND SUSPENSION**

When using conventional buses for BRT operations, the chassis designs could, of course, span the wide range of designs available. There are a few locales where single-body and otherwise wholly conventional designs are used, such as the Los Angeles Metro

Rapid, but most applications will likely be of single-articulated design. These provide high capacity, and can operate on the same geometric alignments as single-body buses. When a dedicated right-of-way is available and passenger flows are significant, bi-articulated vehicles can be used, as in Curitiba.

In conventional buses, engines can be mounted longitudinally, transversely, or even vertically. The most common has been the transverse mount in the rear. The longitudinal approach has been used with “pancake” motors, that is, motors with all cylinders on one plane. The engine is placed under the floor mid-bus, and the drive train layout is the same as a rear-wheel drive automobile. A vertical mounting allows the engine to be placed in a back corner of the bus, but it requires an unconventional drive train to power the rear axles.

The trend in all developed countries is to replace high-floor buses with low-floor buses. The latter, of course, are easier and quicker to board and alight since there are no steps. It also obviates the need for wheelchair lifts, an expensive and trouble-prone component. There are disadvantages, however. Since the wheel diameter is the same, the front wheels now protrude into the passenger compartment to such a height as to render this area unavailable for seating.

A compromise solution long popular in much of Europe, and increasingly popular in North America, is the *70 percent low floor* bus. The idea is to have a low floor until just behind the rear door. This allows ready access to the front part of the bus, but at the same time permits a wholly conventional drive train design in the rear, since the floor is higher. The drawback is that there must be internal steps, but this can be ameliorated by

using a sloping floor rather than level rear section. This solution can be used for articulated as well as standard length buses, if only the rearmost axle is to be powered.

Another possibility is to use high-floor buses of conventional design in an all high-platform system. This is completely analogous to rail rapid transit operation. This allows the use of the simplest bus design – a high-floor bus without either stairs or wheelchair lift. The disadvantages are also evident. The bus can only serve stops with high platform infrastructure, but wholly suitable for BRT operations where the bus never branches into service areas without high platforms. This has been used in the ultra-high capacity BRT operations in Curitiba and Bogotá.

Virtually all conventional bus designs use a rigid steel frame for the basis of the chassis, although in some designs, actually constructed from a pre-assembled steering module for the front and pre-assembled power module for the rear. In a non-articulated bus, the two are then linked with beams at final assembly. Articulated buses are more complex. They have a turntable joint approximately one meter (three feet) behind the rear axle of the front section. In addition to rotation in the horizontal plane, they can pivot to approximately 15 degrees in the vertical plane to allow climbing and descending hills. Although complicated, these turntables have been perfected through many years of use. There are also a few articulated designs where a linkage connects between the front steered axle and the rearmost axle. This link will turn the rear axle one-half the angle of the front axle to improve maneuverability.

A modern transit bus chassis is supported by an active air suspension to provide a comfortable ride and reduce harmful jolts and shocks to the frame and bodywork. They will often have a *kneeling* ability. The air is quickly relieved from airbags on the door

side of the vehicle or perhaps the entire vehicle is lowered. This facilitates matching of the door to uneven curb heights and helps the elderly and disabled to board where there are no curbs. The airbags can quickly be refilled, using the compressed air system also powering the brakes.

Specialized BRT vehicles are all of low-floor design. They use hub motors to facilitate 100 percent low floor interiors. The motor and generator are mounted transversely in the rear, much like the conventional bus designs, but do not need the mechanical drive trains. All designs make provision in their chassis layout to accommodate fuel cell propulsion plants in the future. The retractable mechanical guides used in several of the designs add to the underside complexity.

At least one specialized vehicle is available either in standard or articulated model. At least two others are available in either an articulated or double-articulated model. There can be some significant differences, however, from conventional designs. The Bombardier-Spies GLT uses the standard technique of mounting the wheels a short distance ahead of the articulation joint, but adds swivel capability to the wheels in order to tighten the turning radius. This design has experienced some difficulties in early revenue service. The Translohr STE design places the wheels directly under the articulation joint, in a manner reminiscent of LRVs, but with the important difference that these are just single-axled with rubber tires rather than tandem axles with steel wheels. The Irisbus Civis uses the same articulation technique as conventional buses. Experience with these vehicles in revenue service will reveal which designs have the best combination of maintainability, economy, reliability and ride comfort.

### **E-3.1. Body Features**

Conventional buses used for BRT operation are very likely to be selected in large part for their high quality and aesthetically pleasing bodywork, given its importance to the image of a BRT system. Large side windows and a large front windscreen not only contribute to the outward image, these are essential to creating a well-lit interior and excellent view for passengers. Special attention must be paid to the finish and details. The body must be able to retain a high-quality finish. Designs that facilitate the rapid replacement of damaged panels are highly desirable.

Table E-1 lists some key dimensions of selected buses. Buses for BRT application tend to have similar overall dimensions to those used for general purpose. This is because they must generally be able to use public roadways and, in some cases, share even dedicated busways with general-purpose buses. There are exceptions where bi-articulated buses of abnormal length can be used, such as Curitiba, Brazil. This is facilitated by a special roadway system specifically designed for oversized buses. Finland and Sweden permit bi-articulated buses even on some roads open to the public. Their use in North America would require special dispensation.

Specialized BRT vehicles usually have an LRT vehicle -like appearance. All tires are covered on most specialized vehicles, as visible rubber calls attention to the essential bus-like nature of the vehicle. Several of the vehicles have an option to place the driver in the center rather than to the left, also in keeping with LRV design concepts. Whether this option should be selected depends upon the portion of driving that occurs off the dedicated right-of-way, as drivers might prefer the left position in mixed traffic.

All vehicles, whether of specialized or conventional design, must have large doorways. The BRT concept demands quick passenger interchanges. Most designs have



some flexibility in the number of doors. In general, too many doors would be better than too few. Sacrificing some seating space in the interest of shorter dwell times is a tradeoff that requires serious consideration. A few BRT-like operations have taken the step of marking half the doors for boarding, and half for alighting, in the interest of reducing friction.

Also requiring consideration, regardless of bus design, are the amenities and comfort provided. Buses for BRT operation are clearly intended to see heavy volumes of boarding and alighting, which argues for a rugged interior. On the other hand, the strong image requires a softer interior. Thus, seats should be comfortably padded. A compromise solution that protects the interior is folding seats along the walls that keep them out of the way when not being used. This has the further advantage of providing extra standing space during periods of crowding.

Conventional buses should have an interior layout with standing room and stanchions at the vestibules at each door, with the possible exception of the front door. This space also serves as a storage area for luggage, baby carriages, shopping carts, and perhaps even bicycles, in the off-peak period. If used, fare cancellation machines can be placed on stanchions near the doorways. If there are to be cash fare payments onboard, they are likely to occur at the front door.

The North American solution to wheelchair provision is to put a forward facing tie-down at one or more of the vestibules. The European approach and the one likely to be provided with the specialized vehicles, unless otherwise requested, is different. It uses two strong stanchions with backward facing pad bridging them. The wheelchair can

simply back up against it without using a restraint. This provides automatic protection against hard braking and forward collisions.

On all low floor buses, regardless of bus design, the large wheel wells limit the flexibility of use near the front door. Some layouts now use a pedestal just before and after the wheel well with pairs of forward and backward facing seats placed on top. This can also be done at any intermediate and rear wheel wells. An alternative solution is to use the area atop the wells as a luggage storage area.

Specialized vehicles are designed to permit a variety of seating configurations, including some curved seats almost resembling couches. Another possibility is face-to-face seating, popular in some rail vehicles. Thus, the layout can be selected in accordance with local customs and preferences. In at least one of the vehicles, the seating configuration can be changed fairly quickly, permitting experimentation, changes for different seasons, for different routes, etc.

The choice of body materials for both conventional and specialized vehicles remains the same plastics, aluminum, mild steel and stainless steel that have been used in the past. Regular mild steel is in most common use, but many specialized BRT vehicles (e.g., Civis) are made of stainless steel and can be expected to have a significantly longer body and life, in excess of 18 years before a major rebuild instead of the normal 12 in the U.S. Composites are also being used with some success by at least one vendor (North American Bus Industries). These materials may become increasingly popular. This allows *unibody* construction, that is, the body and chassis can be combined. Indeed, the body wraps around and encloses almost the entire underside. The result is a vehicle that is substantially lighter for a given vehicle size, or conversely, a larger vehicle can be built

of the same weight. For example, North American Bus Industries currently offers a 45-foot-long composite bus of similar weight to their 40-foot standard bus.

#### **E-4. AUXILIARIES**

Most auxiliaries on buses for BRT operations will be similar to those already in use. These include air-conditioning, air compressors, fuel tanks in the case of onboard prime movers, propulsion control electronics in the case of electric prime movers and hybrid drives, ITS peripherals, etc. The exact location of auxiliary components depends upon the chassis and propulsion plant configuration used. Low-floor and alternative-fueled buses are already widespread, and most transit agencies have become accustomed to the different servicing procedures required to reach auxiliaries relocated to more difficult-to-reach locations. Some of these may be reachable only with redesigned workspaces having gangways at roof level. This is particularly likely to be the case with the new specialized bus designs.

The most likely new addition will be the energy storage medium, as hybrid drives become more popular and the weight of these can be reduced. Location of very heavy items like storage batteries, magneto motors or flywheels is exceedingly unlikely on the roof because they would raise the center of gravity and jeopardize the stability of the bus. There are also some safety concerns in case of component failure that need to be addressed, likely requiring some shielding of the passenger compartment.

There are plans in the industry to switch from 12 volt to 42-volt batteries to accommodate increasing electrical demand for both electronics and auxiliaries. All new bus designs that are intended to accommodate future propulsion plants will need to be

flexible in their design to accommodate the continued growth in the number and type of auxiliaries.

#### **E-5. TOTAL SYSTEM COSTS**

The manufacturers of the specialized vehicles state that these are actually part of a larger system that includes the guidance infrastructure and stations, analogous to a rail system. Thus, contract costs quoted in the trade media typically include both. Some of these are listed here:

##### **Bombardier GLT – Caen, France**

Guideway length	16 kms
Number of vehicles	24
Contract cost	1.2 Billion French Francs (signed in 1994)

##### **Bombardier GLT – Nancy, France**

Guideway length	8.7 kms (11 km route length)
Number of vehicles	25
Number of stops	28
Contract cost	900 Million French Francs (signed in 1999)

##### **Civis – Clermont-Ferrand, France**

Guideway length	14 kms
Number of stops	30
Number of vehicles	22
Contract cost	115.9 Million Euros (signed in 2001)

##### **Civis – Rouen, France**

Guideway length	15.7 kms (24 kms total on 3 overlapping routes)
-----------------	---

Number of stops 46

Number of vehicles 17 Civis + 38 Agora

Contract cost 1 Billion French Francs (signed in 1999)

#### **E-6. CONCLUSION**

BRT may use conventional or specialized vehicles. High-end conventional vehicles work well when matched to the remainder of the system. The door heights, fare collection techniques, and other factors influencing passenger exchange and dwell times must be considered together with the static infrastructure. In the interest of their image, these buses are also likely to be the state-of-the-practice in noise and air pollution reduction.

Purpose-built, specialized vehicles cost more but have additional advantage that offset their higher cost than conventional buses. They cost substantially less than LRVs, but can provide an image similar to LRVs. Their complexity will make them more difficult to absorb within the daily procedures of most transit agency bus maintenance and training facilities. Incorporating them will be similar to incorporating rail vehicles into a previously all bus agency.

Since they are used in a high-demand part of a transit network where traffic is concentrated, typically a trunk line with many connecting services, they will tend to be equipped with a full complement of ITS technologies. These will be used to manage connections and to inform passengers about network-related delays and the status of connections. Moreover, all aspects of BRT bus design must always be done in consideration of the role that these special buses play. They are both a high-profile key

portion of the transit network, and a service that must be highly integrated for the convenience of the passengers connecting to and from the remainder of the network.

Diesel-electric or dual-mode propulsion is most often used for specialized BRT vehicles, rather than true hybrid drive with on-board energy storage. Conventional designed buses using true hybrid drive are in limited revenue service. Both of these types of bus designs remain far more expensive than conventional buses, but the gap will narrow with increased production. Provision is being made in most designs for the eventual adoption of fuel cell propulsion. Refinement of designs continues.

**APPENDIX E**

**REFERENCES**

Bouwman, Ruud, 2001. “Phileas a Modern 24 Metre Hybrid Public Transport Vehicle” Advanced Public Transport Systems, Helmond, Netherlands.

Essen Verkehrs AG, 1992. “Spurbus Essen: Information on the Research and Development Project Guided Bus Essen Phase III”

Shiavone, John, 1998. “Understanding Onboard Electronics for Buses”, Transit Cooperative Research Program Report No. 43, Transportation Research Board, Washington, DC.

Ventejal, Phillipe, 2001. “Trams and Rubber-tyred Guided Vehicles”, Savior Faire, volume 37, April, RATP, Paris.

Volvo Mobility Systems Corporation, 2001. “What is ITS Mobility?” Gothenburg, Sweden.

**TABLE E-1**

**DIMENSIONS FOR A VARIETY OF BUSES AND SPECIALIZED BRT VEHICLES**

Vehicle	Length	Width	Floor Height (mm)	Doors	Empty Weight	Docking?
LF North American Bus (NABI)	12	X2.44 or 2.60	380	1,1		
LF North American trolleybus (Boston Neoplan N6141 DET)		X2.44				No
LF North American Bus (NABI composite)	13.7	X2.60	380 & 825	1,1		No
LF North American Bus (New Flyer)	18	X2.60	400	1,1,2	18.9	No
LF North American Bus (New Flyer hybrid)	18	X2.60	400	1,2	19.7	No
LF European Artic. Bus (Scania)	18	X2.50 or 2.55		2,2,2,2	16	No
Neoplan N6121 DET (dual-mode)	18	X2.55 or 2.80		1,2,2,2	28.6	
Irisbus Cavis Single	12	X2.55	320-400	1,2		Yes
Irisbus CIVIS artic.	18 <sup>1</sup> or 19.5 <sup>2</sup>	x 2.55	320-400	1,2,2,2	18.4 or 18.4	Yes
APTS Phileas artic.	18	x 2.54	320-340	2,2,2	16.8	Yes
APTS Phileas bi-artic.	24	x 2.54	320-340	2,2,2,2	21.7	Yes
Bombardier-Spies GLT artic.	18	x 2.5	320-370			Yes
Bombardier-Spies GLT bi-artic.	24.5	x 2.5	320-370	2,2,2	25.5	
Translohr STE3 bi-artic.	24.5	x 2.2	250	2,2,2		Yes
Volvo bi-artic. (Curitiba)	24		800 approx	2,2,2,2		No
Mercedes Artic (Bogota)	18		800 approx	4,2,2		No
Breda artic. (Seattle dual mode)	18			2,2,2		No

1 – diesel-electric

2 - overhead collection and batteries

3 - this is the range of floor heights on the main floor before kneeling



WMATA Farebox with Magnetic Stripe and  
Smart Card Reader-Writer  
Photo E1



Specialized BRT Vehicle Interior:  
Bombardier GLT  
Photo E2



Specialized BRT Vehicle Interior:  
Irisbus CiviS  
Photo E3

APPENDIX F

COMPARISON TABLES OF BRT SYSTEMS FROM CASE STUDY REPORT

(Tables A-1 through A-12 were previously published in Appendix A of *TCRP Report 90, Volume 1.*)

TABLE A-1 Summary of BRT systems surveyed

CITY	URBANIZED AREA POPULATION (MILLIONS)	CENTRAL BUSINESS DISTRICT (CBD) EMPLOYMENT	RAIL TRANSIT IN CITY	BRT STATUS/ YEAR FIRST OPENED	SYSTEM OVERVIEW
US/CANADA					
1. Boston	3.0	365,000	√	First Section Opened July 2002	"Silver" Line includes bus tunnel and will have articulated dual-mode trolley and CNG-powered buses.
2. Charlotte	1.1	50,000		1997	Use of peak-period freeway bus lane by express buses in Independence Blvd. Corridor.
3. Cleveland	2.0	100,000	√	Under Construction	Euclid Ave. Median Busway will have articulated hybrid diesel-electric buses.
4. Eugene	0.2	N/A		Proposed	Project includes exclusive transit lanes used by low-floor guided vehicles.
5. Hartford	0.8	52,000		Under Construction	New Britain-Hartford Busway with stations along unused railroad busway.
6. Honolulu	0.9	N/A		1999	Three City Express <sup>1</sup> and Country Express <sup>1</sup> routes provide limited-stop service using distinctively colored articulated buses.
7. Houston	1.8	150,000		1979	Harbor and Santa Monica Freeway HOV lanes have express bus service and stations.
8. Los Angeles	9.6 <sup>(1)</sup>	200,000	√	1977	San Bernardino Busway (later HOV Busway) opens.
				1979	Harbor and Santa Monica Freeway HOV lanes have express bus service, stations.
				1999	Wilshire-Whittier and Ventura Bvds. "Metro Rapid" limited-stop service uses distinctively colored low-floor CNG buses.
9. Miami	2.3	50,000	√	1996	Miami-South Dade Busway along abandoned railroad line connects with Miami Metro.
10. New York City	16.0	1,850,000	√	1963	Express buses use contra-flow bus lanes on three radial freeways; extensive bus lane network in Manhattan; limited-stop bus service on 25 routes in all 5 boroughs.
11. Ottawa	0.7 <sup>(2)</sup>	86,500		1983	Extensive busway system with attractive stations offers all-stop and express service.
12. Pittsburgh	1.7	140,000	√	1977	South, East, and West Busways offer all-stop and express service.

(continued)

TABLE A-1 (continued)

CITY	URBANIZED AREA POPULATION (MILLIONS)	CENTRAL BUSINESS DISTRICT (CBD) EMPLOYMENT	RAIL TRANSIT IN CITY	BRT STATUS/ YEAR FIRST OPENED	SYSTEM OVERVIEW
13. Seattle	1.8	120,000		1990	Bus tunnel is used by articulated dual-mode trolley and diesel buses.
14. Vancouver	2.1	130,000	√	1996	Broadway and Richmond "B-Line" limited-stop BRT service using distinctive low-floor articulated buses.
<b>AUSTRALIA</b>					
15. Adelaide	1.1	N/A	√	1989	O-Bahn 7-mile guided busway offers both express and local service.
16. Brisbane	1.5	60,000	√	1990	South East Busway BRT with attractive stations offers both express and all-stop service. Buses use CBD bus tunnels.
17. Sydney	1.7	400,000	√	Under Construction	Liverpool-Parramatta BRT will include busways, bus-only roads, and stations. Service pattern will provide both express and all-stop routes.
<b>EUROPE</b>					
18. Leeds (U.K.)	0.7	N/A		1995	"Superbus" guided buses bypass queues in Scott Road Corridor and is under construction in York and Selby Road Corridor.
19. Rouen (France)	0.4	N/A	√	2001	Three-route optically guided buses use modern Irisbus Cavis "train-like" buses.
20. Runcorn (U.K.)	0.1	N/A		1973	"Figure 8" busway system is integrated with development in planned New Town.
<b>SOUTH AMERICA</b>					
21. Belo Horizonte (Brazil)	2.2	N/A	√	1981	Avenida Christiano Machado Median busway, with passing capabilities at station.
22. Bogotá (Colombia)	5.0	N/A		2000	23-mile, 4-lane "TransMilenio" median busway with high-platform center island stations, where fares are paid, is served by articulated buses.
23. Curitiba (Brazil)	1.6	N/A		1973	5 median busway system along 5 structural axes is carefully integrated with city development. Bi-articulated buses provide frequent rapid-transit service to high-platform stations, terminals. Express (direct) service on nearby one-way streets.

(continued)

TABLE A-1 (continued)

CITY	URBANIZED AREA POPULATION (MILLIONS)	CENTRAL BUSINESS DISTRICT (CBD) EMPLOYMENT	RAIL TRANSIT IN CITY	BRT STATUS/ YEAR FIRST OPENED	SYSTEM OVERVIEW
24. Porto Alegre (Brazil)	1.3	N/A	√	1978	Four-corridor median busway system uses bus-ordering system to accommodate heavy passenger and bus flows.
25. Quito (Ecuador)	1.5	N/A		1996	Trolleybus median busway system utilizes articulated, all-electric, trolley buses and high-platform stations with fare prepayment.
26. Sao Paulo (Brazil)	8.5	Over 1.0 million	√	1975	Extensive busway system includes D-Julho and Sao Mateua Sabaquara. Median busways have staggered island platform stations with passing capabilities.

Source: Individual Case Studies.

(1) Country Population. (2) Excludes Hull, Quebec.



**TABLE A-2 BRT system features**

CITY	URBANIZED AREA POPULATION (MILLIONS)	FACILITY DESCRIPTION	RUNNING WAY	STATIONS	DISTINCTIVE, EASY-TO-BOARD VEHICLES	OFF-VEHICLE FARE COLLECTION	ITS	FREQUENT, ALL-DAY SERVICE
<b>US/CANADA</b>								
1. Boston	3.0	Silver Line – Bus Tunnel, Lanes	√	√	√	√	√	√
2. Charlotte	1.1	Independence Blvd. Freeway Busway	√	√				
3. Cleveland	2.0	Euclid Ave. – Arterial Median Busway	√	√	√		√	√
4. Eugene	0.2	Eugene-Springfield Arterial Median Transit Corridor Phase 1 (East-West)	√	√	√	√	√	√
5. Hartford	0.8	New Britain–Hartford Busway	√	√			√	
6. Honolulu	0.9	City Express! and County Express! (Mixed Traffic)	√	√	√			√
7. Houston	1.8	High Occupancy Vehicle (HOV) Lane System	√	√	e			
8. Los Angeles	9.6	Harbor Freeway HOV/Busway San Bernardino Freeway HOV/Busway Wilshire-Whittier & Ventura Metro Bus (Mixed Traffic)	√	√	√		√	√
9. Miami	2.3	Miami-S. Dade Busway	√	√				√
10. New York City	16.0	I-495 NJ, I-495 NY, Gowanus AM Contra-Flow Lanes Arterial Limited Stop Service	√	√				√
11. Ottawa	0.7	Transitway System (Busway, Bus Lanes)	√	√			√	√
12. Pittsburgh	1.7	South, East, West Busways	√	√				√
13. Seattle	1.8	Bus Tunnel	√	√	√			√
14. Vancouver	2.1	Broadway & Richmond “B” Lines (Mixed Traffic)	a	√	√		√	√
<b>AUSTRALIA</b>								
15. Adelaide	1.1	O-Bahn Guided Busway	√	√				√
16. Brisbane	1.5	South East Busway	√	√			√	√
17. Sydney	1.7	Liverpool-Parramatta Busway – Bus Lanes	√	d			√	d

(continued)

**TABLE A-2 (continued)**

CITY	URBANIZED AREA POPULATION (MILLIONS)	FACILITY DESCRIPTION	RUNNING WAY	STATIONS	DISTINCTIVE, EASY-TO-BOARD VEHICLES	OFF-VEHICLE FARE COLLECTION	ITS	FREQUENT, ALL-DAY SERVICE
<b>EUROPE</b>								
18. Leeds (U.K.)	0.7	Superbus Guided Bus System	b	d				√
19. Rouen (France)	0.4	Optically Guided Bus – Bus Lanes	√	√	√	g	√	√
20. Runcorn (U.K.)	0.1	Figure 8 Busway	√	√				√
<b>SOUTH AMERICA</b>								
21. Belo Horizonte (Brazil)	2.2	Avenida Cristiano Median Busway	√	c				√
22. Bogotá (Colombia)	5.0	TransMilenio Median Busway	√	√	√	√	√	√
23. Curitiba (Brazil)	1.6	Median Busway System	√	√	√	√	√	√
24. Porto Alegre (Brazil)	1.3	Assis Brasil & Farrapos Median Busways	√	d				
25. Quito (Ecuador)	1.5	Trolebus Median Busway	√	√	√	√	√	√
26. Sao Paulo (Brazil)	8.5	9 De Julho & Jaraquara Median Busways	√	f				√

Source: Individual Case Studies.

Notes:

- (a) Has a short median busway.
- (b) Queue bypasses at congested locations.
- (c) 4 terminal stations.
- (d) Not specified.
- (e) Uses over-the-road coaches.
- (f) Median bus stops.
- (g) Limited.

**TABLE A-3 Running way characteristics**

CITY	URBANIZED AREA POPULATION (MILLIONS)	FACILITY DESCRIPTION	LENGTH (MILES)	NUMBER OF STATIONS	COSTS (MILLIONS)	COMMENTS
<b>US/CANADA</b>						
1. Boston	3.0	Silver Line – Bus Tunnel, Lanes		10	\$1.35 US	Full development (includes subway)
2. Charlotte	1.1	Independence Blvd. Freeway Busway	2.9	0		
3. Cleveland	2.0	Euclid Ave. – Arterial Median Busway	7.0	30	\$220 US	
4. Eugene	0.2	Eugene-Springfield Phase I East-West Corridor	4.0	N/A	\$11 US	Phase I
5. Hartford	0.8	New Britain – Hartford Busway	9.6	12	\$100 US	
6. Honolulu	0.9	City Express! and County Express! (Mixed Traffic)	26.6			Excludes County Express! mileage transit centers
7. Houston	1.8	High Occupancy Vehicle (HOV) Lane System	111.0		\$980 US	
8. Los Angeles	9.6 <sup>a</sup>	Harbor Freeway HOV/Busway	11.8	9	N/A	
		San Bernardino Freeway HOV/Busway	12.0	3	\$75.0 US	
		Wilshire-Whittier (Mixed Traffic)	26.0	30	\$5.0 US	
		Ventura Metro Bus (Mixed Traffic)	16.0	15	\$3.3 US	
9. Miami	2.3	Miami-S. Dade Busway	8.2	15	\$59.0 US	
10. New York City	16.0	I-495 NJ, I-495 NY, Gowanus	2.5	0	\$0.7 US	
		AM Contra-Flow Lanes	2.2	0	\$0.1 US	
		Arterial Limited Stop Service	5.0	0	\$10.0 US	
11. Ottawa	0.7 <sup>b</sup>	Transitway System (Busway, Bus Lanes)	37.0	28	\$435 C	
12. Pittsburgh	1.7	South Busway	4.3	9	\$27 US	
		East Busway	6.8	6	\$113 US	
		West Busway	5.0	6	\$275 US	
13. Seattle	1.8	Bus Tunnel	2.1	3	\$450 US	
14. Vancouver	2.1	Broadway “B” Line (Mixed Traffic)	11.1	14	\$13 C	Includes cost for Richmond Center Busway
		Richmond “B” Line (Mainly Traffic)	9.8	N/A	\$46.9 C	
<b>AUSTRALIA</b>						
15. Adelaide	1.1	O-Bahn Guided Busway	7.4	3	\$104 A	
16. Brisbane	1.5	South East Busway	10.5	10	\$400 A	Stations on busway exclude downtown tunnel costs
17. Sydney	1.7	Liverpool-Parramatta Busway – Bus Lanes	19.0	35	\$200 A	13 miles busway 6.0 miles bus lanes

(continued)

**TABLE A-3 (continued)**

CITY	URBANIZED AREA POPULATION (MILLIONS)	FACILITY DESCRIPTION	LENGTH (MILES)	NUMBER OF STATIONS	COSTS (MILLIONS)	COMMENTS
<b>EUROPE</b>						
18. Leeds (U.K.)	0.7	Superbus Guided Bus System	0.9	N/A	1.35 US	
19. Rouen (France)	0.4	Optically Guided Bus – Bus Lanes	28.5	61	200 US	Costs for 2 main lines based on 12.2 million per mile
20. Runcorn (U.K.)	0.1	Figure 8 Busway	14.0	56	15.0 US	¼-mile spacing
<b>SOUTH AMERICA</b>						
21. Belo Horizonte (Brazil)	2.2	Avenida Cristiano Median Busway	5.6	15	N/A	200-ft stop spacing
22. Bogotá (Colombia)	5.0	TransMilenio Median Busway	23.6	59	184 US	Based on \$8 million/mile
23. Curitiba (Brazil)	1.6	Median Busway System	37.2	139		410-ft stop spacing
24. Porto Alegre (Brazil)	1.3	Assis Brasil Median Busway	3.6	10		1960-ft stop spacing
		Fatrapos Median Busway	3.3	9		
25. Quito (Ecuador)	1.5	Trolebus Median Busway	10.0	32	57.6 US	1640-ft stop spacing
26. Sao Paulo (Brazil)	8.5	9 De Julho Median Busway	7.0	18		2000-ft stop spacing
		Jaraquara Median Busway	13.0	34		

Source: Individual Case Studies

Notes:

N/A – Not Available  
A – Australian dollars  
C – Canadian dollars  
US – US dollars

<sup>a</sup> Los Angeles County only

<sup>b</sup> Excludes Hull, Quebec which brings population to over 1 million

**TABLE A-4 Station characteristics (selected systems)**

CITY	FACILITY DESCRIPTION	NUMBER OF STATIONS	AVERAGE STATION SPACING (FEET)	LOCATION	LENGTH IN FEET (NUMBER OF BUSES)	PASSING LANES	PLATFORM HEIGHT	FARE COLLECTION (PRE-PAYMENT)
<b>US/CANADA</b>								
1. Boston	Silver Line – Bus Tunnel/ Lanes <sup>1</sup>	10	2,160	Side, Tunnel, Curb, Surface	220 (3)	Selected Tunnel Stations	Low	In Tunnel
3. Cleveland	Euclid Ave. – Arterial Median Busway	30	1,250	Median CBD Side Elsewhere	(2)	In CBD	Low	Possibly
4. Eugene	Phase I East-West Corridor	8	2,400	Median	160 (2)	Yes	Low	Yes
5. Hartford	New Britain–Hartford Busway	12	4,220	Side	(2)	Yes	Low	No
7. Houston	High Occupancy Vehicle (HOV) Lane System		N/A	Off-line	N/A	N/A	Low	No
8. Los Angeles	Harbor Freeway Busway	9	7,240	Side				
	San Bernardino Freeway HOV/Busway	3	21,000	Center				
	Wilshire-Whittier Metro Bus	30	4,580	Curb		General Traffic Lanes	Low	No
	Ventura Metro Bus	15	5,630	Curb			Low	No
9. Miami	Miami-S. Dade Busway	15	2,890	Side	(2–3)	Yes	Low	No
10. New York City	AM Contra-Flow Lanes	0		Side	N/A	Some	Low	No
11. Ottawa	Transitway System (Busway, Bus Lanes)	28	6,980	Side	180	Yes	Low	No
12. Pittsburgh	South, East, & West Busways	21	4,200	Side	120–240	Yes	Low	No
13. Seattle	Bus Tunnel	3	3,870	Side	(2)	Yes	Low	No
14. Vancouver	Broadway “B” Line (Mixed Traffic)	14	4,190	Side	N/A	Traffic Lanes	Low	No
	Richmond “B” Line (Mixed Traffic)	N/A	N/A	Side	N/A	Traffic Lanes		
<b>AUSTRALIA</b>								
15. Adelaide	O-Bahn Guided Busway <sup>2</sup>	3				None	Low	No
16. Brisbane	South East Busway	10	5,540	Side	N/A	Yes	Low	Ticket Machine
17. Sydney	Liverpool-Parramatta Busway – Bus Lanes	35	2,870	Curb	N/A	N/A	Low	No

(continued)

**TABLE A-4 (continued)**

CITY	FACILITY DESCRIPTION	NUMBER OF STATIONS	AVERAGE STATION SPACING (FEET)	LOCATION	LENGTH IN FEET (BUSES)	PASSING LANES	PLATFORM HEIGHT	FARE COLLECTION (PRE-PAYMENT)
<b>EUROPE</b>								
18. Leeds (U.K.)	Superbus Guided Bus System	3	N/A	Island	(1)	No	Low	No
19. Rouen (France)	Optically Guided Bus – Bus Lanes	61	2,470	Curb or Island	Limited	Yes	Low	Some
20. Runcom (U.K.)	Figure 8 Busway	56	1,320	Curb	(2)	Yes	Low	No
<b>SOUTH AMERICA</b>								
21. Belo Horizonte (Brazil)	Avenida Cristiano Median Busway	15	2,000	Side	(1–4)	Yes	Low	Some
22. Bogotá (Colombia)	TransMilenio Median Busway	59	2,110	Center Island	130–490	Yes	High	Yes
23. Curitiba (Brazil)	Median Busway System <sup>3</sup>	139	1,410	Side, Island	80 (1)	Yes	High	Yes
24. Porto Alegre (Brazil)	Assis Brasil Median Busway	10	1,000	Side	N/A	Yes	Low	No
	Farrapos Median Busway	9	1,000	Side	N/A	Yes	Low	No
25. Quito (Ecuador)	Trolebus Median Busway	32	1,640	Side, Center	(1)	No	High	Yes
26. Sao Paulo (Brazil)	9 De Julho Median Busway	18	2,000	Side	(2–3)	Yes	Low	Some
	Jaraquara Median Busway	34	2,000	Side	(2–3)	Yes	Low	Some

Source: Individual Case Studies

Notes:

N/A – Not Available

<sup>1</sup>Four stations in tunnel, six on surface

<sup>2</sup>Three stations on guided busway

<sup>3</sup>139 stations including 26 integration terminals

**TABLE A-5 Station features and amenities (selected systems)**

CITY	FACILITY	FEATURES
1. Boston	Silver Line	Mezzanines in 4 tunnel stations with fare collection provisions. 6 curbside stations on Washington Street have seating, information panels, telephones, trash receptacles, and communications panel.
3. Cleveland	Euclid Ave.	Shelters, amenities, and possibly fare vending machines.
5. Hartford	New Britain-Hartford Busway	Passenger drop-off areas, some park-and-ride. Full range of amenities, climate-controlled buildings, restrooms, and telephones at major stations.
7. Houston	Transit Centers	Have extensive park-and-ride lots at stations.
8. Los Angeles	San Bernardino HOV/Busway Wilshire-Whittier Ventura Metro Bus	Circular island at El Monte Station, large park-and-ride lot there. Major stations – double canopy, “Next Bus” display signs. Other stations – single canopy shelter and bollards.
9. Miami	South Miami-Dade	Translucent, waterproof, fiber canopies; pay telephones; and benches.
10. New York City	I-495 Bus Lane	New Jersey buses use 200-berth Midtown Bus Terminal.
11. Ottawa	Transitway System	Passenger shelters, radiant heat, benches, telephones, television monitors announcing bus arrivals.
12. Pittsburgh	Busways	Simple shelters, some with telephones.
13. Seattle	Bus Tunnel	Architectural features such as murals/clocks.
14. Vancouver	B-Lines	Well-lit, distinctive shelters; real-time electronic bus information displays; customer information signage.
15. Adelaide	On Guided Busway	Protected shelters; bicycle access/storage; short-/long-term parking.
16. Brisbane	South East Busway	Architecturally distinctive designs, passenger protection, elevators and stairs, covered pedestrian bridges over busway, real-time passenger information, displays, ticketing machines, public telephones, passenger seats, drinking fountains, retail kiosks, public restrooms, security systems.
17. Sydney	Liverpool-Parramatta Busway – Bus Lanes	Real-time passenger information, lighting, and security cameras.
20. Rouen	Optically Guided Bus Lanes	Most stations are simple bus shelters; some have ticketing provisions.
22. Bogotá	TransMilenio	Similar to rapid-transit station in design; fare payment provisions; high platform.
23. Quito	Trolebus	Tube-like shelter at stations; off-vehicle fare collection; high platform.

**TABLE A-6 Vehicle characteristics (selected systems)**

CITY	FACILITY	VEHICLE TYPE	PROPULSION	LEVEL BOARDING	NO. OF DOORS	DOORS SIDE	DISTINCTIVE COLOR/LOGO
<b>US/CANADA</b>							
1. Boston	Silver Line	Articulated	Dual Mode- Trolley & CNG	√	3	Right	
2. Cleveland	Euclid Ave.	Articulated	Diesel-Electric Hybrid	√	3	Both	
4. Eugene	Phase I East-West Corridor	Articulated	Hybrid Electric	√	4	Both	Futuristic Vehicle
6. Honolulu	City Express! And Country Express!	Articulated		√	3	Right	Rainbow Wrap
7. Houston	HOV Express Buses	Over-the-Road Coaches, Articulated	Diesel		1	Right	
8. Los Angeles	Wilshire-Whittier-Ventura	Standard	CNG	√	2	Right	Red Colored Buses
9. Miami	South Dade Busway	Mini/Standard/Articulated	CNG, Diesel	Some	2	Right	
11. Ottawa	Transitway	Articulated/Standard	Diesel	Some	2-3	Right	
12. Pittsburgh	Fast-South-West Busways	Articulated/Standard	Diesel	Some	3	Right	
13. Seattle	Bus Tunnel	Articulated	Dual Mode Trolley/Diesel	√	3	Right	
14. Vancouver	Broadway/Richmond	Articulated	Diesel	√	3	Right	Distinctive Stripes
<b>AUSTRALIA</b>							
15. Adelaide	Guided Busway	Articulated	Diesel		2	Left	
16. Brisbane	South East Busway	Standard	CNG/Diesel	√	2	Left	
<b>EUROPE</b>							
18. Leeds	Superbus Guided Bus	Standard	Diesel	Some	1-2	Left	
19. Rouen	“Teor” System	Articulated	Civis-Irisbus Hybrid-Diesel Electric	√	4	Right	Distinctive Vehicle Appearance and Design
20. Runcorn	Figure 8 Busway	Regular	Diesel		2	Left	
<b>SOUTH AMERICA</b>							
21. Belo Horizonte	Avenida Cristiano Machado	Standard	Diesel				
22. Bogotá	TransMilenio	Articulated	Diesel	√ <sup>a</sup>	3	Left Double Width	Red Bus Special Bus
23. Curitiba	Busway System	Bi-articulated	Diesel	√ <sup>a</sup>	5	Double Width Right	Distinctive Red Color
24. Porto Alegre	Assis Brasil Farrapas	Articulated	Diesel				
25. Quito	Trolebus	Articulated Trolley with Auxiliary	Diesel engines	√ <sup>a</sup>	3	Right	Distinctive Rainbow Wrap
26. Sao Paulo	9 de Julio	Double-Deck, Standard, Articulated	Trolley Diesel		2-3	Both	
	Jaraquara	Varied	Trolley/Diesel		2-3	Both	

Source: Individual Case Studies.  
<sup>a</sup> High-platform loading.

**TABLE A-7 Application of ITS technologies (selected systems)**

CITY	SYSTEM	AUTOMATIC VEHICLE LOCATION (AVL)	TELEPHONE INFO/ STATIONS	PASSENGER INFORMATION AUTOMATED STATION ANNOUNCEMENTS ON VEHICLE	REAL-TIME INFO. AT STATIONS	TRAFFIC SIGNAL PRIORITIES
<b>US/CANADA</b>						
1. Boston	Silver Line	✓	✓	✓	✓	
2. Charlotte	Independence Corridor	✓				✓
3. Cleveland	Euclid Ave.					
4. Eugene	Arterial Median Transitway			✓		✓
5. Hartford	New Britain-Hartford Busway	✓	✓	✓		
8. Los Angeles	Wilshire-Whittier & Ventura BRT	✓				✓
9. Miami	Miami-S. Dade Busway		✓			Removed
11. Ottawa	Transitway		✓	✓	Selected Locations	
12. Pittsburgh	South-East-West Busways		✓	Some Buses		
14. Vancouver	Broadway and Richmond "B" Lines	✓		✓	✓	✓
<b>AUSTRALIA</b>						
16. Brisbane	South East Busway	✓		✓	✓	
17. Sydney	Liverpool-Parramatta BRT	✓			✓	
<b>EUROPE</b>						
19. Rouen	Optically Guided Bus			✓		With Special Bus Signals
<b>SOUTH AMERICA</b>						
22. Bogotá <sup>1</sup>	TransMilenio	✓				
23. Curitiba	Median Busway System			✓		

Source: Individual Case Studies.  
Note: <sup>1</sup>GPS and Control Center.

**TABLE A-8 Service patterns**

CITY	SYSTEM	OPERATES ON FACILITY ONLY	EXPRESS	ALL STOPS	LIMITED STOPS	LOCAL BUS SERVICE (SAME STREET)	FEEDER SERVICE
<b>US/CANADA</b>							
1. Boston	Silver Line Bus Tunnel & Lanes			✓			✓
2. Charlotte	Independence Blvd. Freeway Busway		✓				
3. Cleveland	Euclid Ave. - Median Arterial Busway	✓ <sup>(2)</sup>	✓ <sup>(1)</sup>				✓
4. Eugene	Arterial Median Transitway	✓		✓			✓
5. Hartford	New Britain-Hartford Busway		✓	✓			✓
6. Honolulu	City Express <sup>1</sup> and Country Express <sup>1</sup> Mixed Traffic				✓		✓
7. Houston	High Occupancy Vehicle (HOV) Lane System		✓				
8. Los Angeles	Harbor Freeway Bus & HOV Way		✓		✓		
	San Bernardino Bus & HOV Way		✓				
	Metro Bus - Wilshire-Whittier & Ventura Blvds.				✓	✓	
9. Miami	S. Miami-Dade Busway		✓	✓			✓
10. New York City	Contra-Flow AM Bus Lanes		✓				
	Arterial Limited-Stop Routes				✓	✓	✓
11. Ottawa	Transitway		✓	✓			✓
12. Pittsburgh	South-East-West Busways		✓	✓			✓
13. Seattle	Bus Tunnel			✓			✓
14. Vancouver	Broadway "B" Line (Mixed Traffic)				✓	✓	✓
	Richmond "B" Line (Mixed Traffic)				✓	✓	✓
<b>AUSTRALIA</b>							
15. Adelaide	O-Bahn Guided Busway		✓	✓			
16. Brisbane	South East Busway		✓	✓			✓
17. Sydney	Liverpool-Parramatta Busway Bus Lanes		✓	✓			✓
<b>EUROPE</b>							
18. Leeds	Guided Bus System			✓			
19. Rouen	Optically Guided System Bus Lanes				✓		✓
20. Runcorn	Figure 8 Busway			✓			
<b>SOUTH AMERICA</b>							
21. Belo Horizonte	Avenida Cristiano-Median Busway		✓	✓			
22. Bogotá	TransMilenio Median Busway	✓		✓	✓		✓
22. Curitiba	Median Busway System	✓	✓ <sup>(1)</sup>	✓			✓
23. Porto Alegre	Assis Brasil Median Busway		✓	✓			
	Farrapos Median Busway		✓	✓			
24. Quito	Troleibus Median Busway	✓		✓	✓		
25. Sao Paulo	9 de Julio Median Busway		✓	✓			
	Jabaquara Median Busway		✓	✓			

Source: Individual Case Studies.  
<sup>(1)</sup> Operates on nearby one-way streets.  
<sup>(2)</sup> Under anticipated operating plan.

**TABLE A-9 Passenger volumes, bus flows, and speeds (selected systems)**

CITY	FACILITY (SYSTEM)	WEEKDAY BUS RIDERS	AM PEAK-HOUR, PEAK-DIRECTION		SPEEDS (MPH)	
			BUSES	RIDERS	EXPRESS	ALL STOP
<b>US/CANADA</b>						
1. Boston	Silver Line Bus Tunnel/Lanes	40,000 <sup>(1)</sup> 78,000 <sup>(2)</sup>	75 <sup>(2)</sup>	4,500		
2. Charlotte	Independence Blvd. Busway	1,000 <sup>(2)</sup>				
3. Cleveland	Euclid Ave. Median Busway	29,500 <sup>(3)</sup>				12
5. Hartford	New Britain-Hartford Busway	20,000 <sup>(3)</sup>	20-24	1,000±	38	32
6. Honolulu	Route A City Express!					
	Route B City Express!	11,000 <sup>(4)</sup>				
	Route C Country Express!					
7. Houston	HOV System KATY	9,115	48	2,100	54 <sup>(11)</sup>	
	I-45 North	13,980	63	3,300	54	
	Northwest	6,180	34	1,500	54	
	Gulf	6,685	21	1,200	54	
	Southwest	8,900	54		54	
	Eastex	4,500	22	1,150	54	
8. Los Angeles	Harbor Bus HOV Way	9,600	40 <sup>(2)</sup>	1,800 <sup>(2)</sup>		35
	San Bernardino Bus HOV Way	18,000	70	2,750		43
	Wilshire-Whittier Metro Bus	40,000 <sup>(5)</sup>	30	1,500	14	
	Ventura Blvd. Metro Bus	9,000 <sup>(6)</sup>	15 <sup>(2)</sup>	750 <sup>(2)</sup>	19	
9. Miami	Miami-S. Dade Busway	12,000	20 <sup>(2)</sup>	800 <sup>(2)</sup>	18	12-14
10. New York City	I-495 (NJ) Contra-Flow Lane		650-830 <sup>(7)</sup>	25,000-35,000 <sup>(7)</sup>	35	
	I-495 LI Exp. Contra-Flow Lane		125	5,240		
	I-278 Gowanus Contra-Flow Lane		175	6,180		
	Limited Stop Service - Arterials				8-14	
11. Ottawa	Transitway System	200,000	180-200	10,000	50	24
12. Pittsburgh	South Busway	13,000	50	2,000	40	30
	East Busway	28,000	110	5,400	40	30
	West Busway	7,000	40	1,700	40	30
13. Seattle	Bus Tunnel	46,000	70	4,200 <sup>(3)</sup>		13
14. Vancouver	Broadway "B" Line	26,000	15	1,000 <sup>(3)</sup>		14
	Richmond "B" Line	14,000	15	1,000 <sup>(3)</sup>		14

(continued)

**TABLE A-9 (continued)**

CITY	FACILITY (SYSTEM)	WEEKDAY BUS RIDERS	AM PEAK-HOUR, PEAK-DIRECTION		SPEEDS (MPH)	
			BUSES	RIDERS	EXPRESS	ALL STOP
<b>AUSTRALIA</b>						
15. Adelaide	O-Bahn Guided Busway	30,000		4,000		
16. Brisbane	South East Busway	60,000	150	9,500		
17. Sydney	Liverpool-Paramatta Busway/Lanes	18,000 <sup>(6)</sup>				
<b>SOUTH AMERICA</b>						
21. Belo Horizonte	Avenida Cristiano Machado Median Busway	1,500,000 Systemwide		16,000		17
22. Bogotá	TransMilenio Arterial Median Busway	800,000 <sup>(8, 8a)</sup>		27,000 <sup>(8, 8b)</sup>	19	13
23. Curitiba	Median Busway System	340,000	40	11,000	19	12
24. Porto Alegre	Assis Brasil Median Busway	290,000	326	26,100		11-14
	Farrapos Median Busway	235,000	304 <sup>(9)</sup>	17,500		12-14
25. Quito	Trolebus	150-170,000	40	8,000		11-12
26. Sao Paulo	9 de Julio Median Busway	196,000	220+	18-20,000		12
	Jabaquaro Median Busway	230,000 <sup>(10)</sup>		21,600		14

Source: Individual Case Studies.

Notes:

- <sup>(1)</sup> Values in parentheses for Phase I
- <sup>(2)</sup> Based on 15,700 monthly riders
- <sup>(3)</sup> Year 2000 ridership
- <sup>(4)</sup> Based on 300,000 riders per month
- <sup>(5)</sup> BRT Service only - total daily riders on Wilshire approximate 100,000
- <sup>(6)</sup> BRT Service only - total daily riders approximate 14,000
- <sup>(7)</sup> Facility operates only during AM Peak period
- <sup>(8)</sup> 45,000 total peak riders on system
- <sup>(8a)</sup> Daily traffic with planned extension; about 600,000 existing riders.
- <sup>(8b)</sup> Peak hour, peak direction
- <sup>(9)</sup> PM Peak hour
- <sup>(10)</sup> Based on 70 million riders per year
- <sup>(11)</sup> Overall speeds including downtown distribution - about 25-30mph
- <sup>(a)</sup> Estimated

**TABLE A-10 Reported travel time savings compared with pre-BRT**

City	Facility	Travel Time (Min)			Travel Time Savings		Comments
		Before	After	% Reduction	Total (Min)	Min/Mile	
<b>US/CANADA</b>							
Charlotte	Independence Blvd. Freeway Busway				5-15	1.7-5.1	
Cleveland	Euclid Ave. - Median Arterial Busway	41	32.75	20	8.25	1.2	Anticipated
Eugene	Arterial Median Busway	27	15	46	12	3	Peak Direction
Hartford	New Britain-Hartford Busway	34.6	20.1	42	14.5	1.5	Anticipated
Honolulu	City Express!	35	20	43	15	2.3	Phase 1
Houston	HOV System - Addicks Park/Ride	45	24	47	21	1.1	
	Northwest Park/Ride	50	30	40	20	2.5	
Los Angeles	San Bernardino HOV Busway	48	17	38	31	2.6	3-Person HOV
	Wilshire-Whittier Blvd. Metro Bus	76	55	28	21	1.5	14 Miles
	Ventura Blvd. Metro Bus	56	43	23	13	0.9	14 Miles
New York City	I-495 Contra-Flow Lane (NJ)				18	7.2	AM Inbound
	I-495 L/E Contra-Flow Lane (NY)				15	7.5	Only
	I-278 Gowanus Contra-Flow Lane				20	4.0	Queue Bypass
	Arterial Limited-Stop Service (25 Routes)					0.9	Range by Borough 0.5-1.9
Pittsburgh	South Busway				6-11	1.4-2.6	
	East Busway (Busway Service)	51-54	30	41-44	21-24	3.1-3.5	EBA Route
	West Busway				25-26	5-5.2	AM Inbound Only
Seattle	Bus Tunnel	15	10	33	5	2.4	
Vancouver	Broadway "B" Line				3-10	0.4-0.9	
	Richmond "B" Line				10	1.0	
<b>AUSTRALIA</b>							
Adelaide	O-Bahn Guided Bus	40	25	38	15	2	
Brisbane	Southeast Busway					2	Estimated
Sydney	Liverpool-Parramatta Bus				60	3.1	Maximum Expected
<b>EUROPE</b>							
Leeds	Superbus - Guided Bus (AM peak)				3	10.7	450M Guideway
	Superbus - Guided Bus (PM peak)				5	10.0	800M Guideway
	Superbus - Guided Bus (AM peak)				10		Total System
<b>SOUTH AMERICA</b>							
Bogotá	TransMillenio			32			
Porto Alegre	Farrapos Arterial Median Busway	24	17	29	7	2.1	

Source: Individual case studies

**TABLE A-11 Reported increases in bus riders (selected systems)**

CITY	FACILITY	DESCRIPTION
<b>US / CANADA</b>		
Charlotte	Independence Blvd. Freeway Busway	Monthly ridership increased from 10,100 to 15,700, a 55% increase, since January 1999.
Cleveland	Euclid Ave. Median Arterial Busway	Estimated increase due to BRT from 26,100 to 29,500 per day, or 13%.
Hartford	New Britain-Hartford Busway	Half of estimated 20,000 daily riders expected to be former motorists.
Honolulu	City Express! and Country Express!	Monthly ridership grew from 100,000 to 300,000 from 1999 to 2001.
Houston	Expressway HOV/Busway	18% to 30% of riders did not make the trip before. Up to 72% of riders were diverted from automobiles.
Los Angeles	Wilshire-Whittier and Ventura Metro Bus	26% to 33% gain in ridership. 1/3 of these were riders who made the trip more often, 1/3 were new riders, and 1/3 were diverted from other corridors.
Miami	Miami-South Dade Busway	50% initial ridership gain after service expansion.
Ottawa	Transitway System	Transitway ridership grew 6% from 1998 to 1999. System helps achieve a peak-hour CBD mode split of 70%.
Pittsburgh	East Busway	Riders on East Busway grew from 21,000 in 1983 to 29,000 in recent years (38% increase). In 1983, 1,900 new riders were attracted to the busway; 11% of riders on new routes and 7% on diverted routes had previously used automobiles.
Vancouver	Broadway-Lougheed "B" Line	8,000 new riders when service started. 20% previously used automobiles, 5% represented new trips, and 75% were diverted from another bus line.
<b>AUSTRALIA</b>		
Adelaide	Guided Busway System	Ridership grew from 4.2 million in 1986 to 7.4 million in 1996 (76% increase) at a time when regional transit ridership declined by 28%.
Brisbane	South East Busway	42% gain in ridership from May-October 2001. 375,000 fewer annual private vehicle trips.
<b>EUROPE</b>		
Leeds	Superbus Guided-Bus System	Over 50% reported ridership growth in first 2.5 years.
<b>SOUTH AMERICA</b>		
Curitiba	Median Busway System	Ridership has grown with system expansion and city growth, from 400,000 daily transit trips in 1982 to 1,900,000 in 2001. 27 million fewer automobile trips annually.

**TABLE A-12 Development costs of selected BRT systems**

CITY / FACILITY	Miles	Cost (\$Million)	Cost/ Mile (\$Million)	Notes
<b>BUS TUNNELS</b>				
Boston – Silver Line	4.1	1,350	329	Includes bus lanes
Seattle	2.1	450	214	
<b>BUSWAYS</b>				
Hartford	9.6	100	10	
Houston – HOV System	98	980	20	
Los Angeles – San Bernardino Freeway	12	75	6	
Miami	8.2	59	7	
Ottawa	3.7	293	8	
Pittsburgh – South Busway	4.3	27	6	
East Busway	6.8	130	19	
West Busway	5	275	55	
Adelaide (Guided Bus)	7.4	53	7	
Brisbane	10.5	200	19	Excludes cost of downtown bus tunnel built before busway
Liverpool-Parramatta	19	100	5	
Runcorn	14	15	1	
<b>FREEWAY REVERSIBLE LANES</b>				
New York – I-495 New Jersey	2.5	0.7	0.3	
I-495 New York	2.2	0.1	0.1	
I-278 Gowanus	5	10	2	Involves freeway reconstruction
<b>ARTERIAL STREET MEDIAN BUSWAYS</b>				
Cleveland	7	220	29	
Eugene	4	13	3.2	
Bogotá	23.6	184	8	
Quito	10	57.6	6	
Belo Horizonte			1.6	Excludes buses and terminals
<b>MIXED TRAFFIC/CURB BUS LANES</b>				
Los Angeles	42	8.3	0.2	
Vancouver – Broadway	11	9	1	
Richmond	9.8	44	4.1	
Leeds (Guided Bus)	2.1	5	2.4	
Rouen (Optically Guided Bus)	28.6	200	7	

Note: All costs are listed in U.S. dollars.



Abbreviations used without definitions in TRB publications:

AASHO	American Association of State Highway Officials
AASHTO	American Association of State Highway and Transportation Officials
APTA	American Public Transportation Association
ASCE	American Society of Civil Engineers
ASME	American Society of Mechanical Engineers
ASTM	American Society for Testing and Materials
ATA	American Trucking Associations
CTAA	Community Transportation Association of America
CTBSSP	Commercial Truck and Bus Safety Synthesis Program
FAA	Federal Aviation Administration
FHWA	Federal Highway Administration
FMCSA	Federal Motor Carrier Safety Administration
FRA	Federal Railroad Administration
FTA	Federal Transit Administration
IEEE	Institute of Electrical and Electronics Engineers
ITE	Institute of Transportation Engineers
NCHRP	National Cooperative Highway Research Program
NCTRP	National Cooperative Transit Research and Development Program
NHTSA	National Highway Traffic Safety Administration
NTSB	National Transportation Safety Board
SAE	Society of Automotive Engineers
TCRP	Transit Cooperative Research Program
TRB	Transportation Research Board
U.S.DOT	United States Department of Transportation