



ArcelorMittal

# Stainless Steel in Bridges and Footbridges



transforming  
tomorrow

## What is stainless steel?

Stainless steel is an alloy of steel, chromium and eventually other elements such as nickel or molybdenum. It is the chromium that renders the steel stainless. In fact, by virtue of the chromium's reaction with oxygen, the surface of stainless steel consists of a self-protecting passive layer that automatically regenerates itself if damaged. The other alloying elements (molybdenum in particular) further enhance this corrosion resistance.

According to its constituent elements and their relative percentages, stainless steel breaks down into more than a hundred grades grouped into several major categories that are found in European standard EN 10088. Thus, stainless steel may be ferritic, austenitic, duplex or martensitic. Each category has specific mechanical properties – such as hardness, yield strength, tensile strength, elongation, etc. These properties are decisive in the choice of a grade for one application or another.

Austenitic stainless steels are the most widely used category and today still account for almost 70% of stainless production. However, with the fluctuating cost of nickel in particular, but also of molybdenum, use of the austeno-ferritic duplex category, with a lower content of alloying elements, is increasing. Today, it offers equivalent or even superior quality in terms of corrosion resistance and its superiority in terms of mechanical performance makes it a particularly competitive material in the bridges and footbridges market.



# From lianas to stainless steel



Passerelle Pünt da Suransuns

The building of bridges to cross a river or a ravine, to join the two banks of a river, the two sides of a valley or even two districts of the same town, goes back to very ancient times. The first were built using lianas, tree trunks, stone slabs. Since ancient times, wooden bridges have enabled experimentation with various designs and were followed by stone bridges, which have the advantage of better resistance to fire. In the industrial age, the use of iron and then of steel gradually enabled the design of bolder, more innovative crossings. New techniques, such as suspension, were developed.

At the end of the 18<sup>th</sup> century, the Coalbrookdale bridge in England gave iron its place in the history of bridge-building. Later, the Golden Gate Bridge, completed in 1937, which is almost 2 kilometres long and crosses San Francisco Bay, set the long-held record for the world's largest suspension bridge.

Steel is now in general use for bridge construction but the use of stainless steel is relatively recent, 10 to 15 years. Initially used principally for its anti-corrosion properties in safety components – guardrails, handrails... – stainless steel is now found in structural components, whether in the deck – in the form of beams and welded plate sections, tie-rods – or in the suspension systems – in the form of stays, cables and pylons. It is also present in concrete reinforcement.

# Stainless steel in bridge and footbridge applications



Courtils footbridge over the Canal d'Orléans at Chécy

## Courtils footbridge over the Canal d'Orléans at Chécy, France, 2004

- **Arched footbridge, welded plate girder in 316L (1.4404) stainless steel**
- **Reduced maintenance**

The Courtils pedestrian footbridge connecting the towpath to Chécy is in reality two bridges: the one is a galvanised steel beam bridge, crosses the River Cens and the other, in stainless steel, describes an arch above the Canal d'Orléans. The second comprises two workshop-prefabricated arches: U-shaped welded plate girders produced from 12 mm thick 316L (1.4404) stainless steel plate and joined by welding. The arches are connected by triangular box girders in 3 mm thick plate onto which gratings are secured. The use of stainless steel is justified by the assurance of maintenance-free operation.

Architects: **Espace / Brigit de Kosmi**  
 Consulting engineers: **Terrell Rooke associés / Zbigniew Koszut ing.**  
 Steel construction: **OMS**  
 Contracting authority: **Communauté de communes de l'agglomération orléanaise**

There is not one stainless steel but several categories of stainless steels, each of which comprises several grades. Each category has its properties, and each grade has its specific characteristics that must be taken into account according to the type of structure, its design and the nature of the atmosphere.

### What grades for a bridge?

The choice of grade is influenced by the degree of atmospheric corrosiveness and by the mechanical properties – yield strength and tensile strength in particular. The more corrosive the atmosphere, chloride-laden

for example, the greater must be the steel's corrosion resistance. The greater the bridge's span, the more demanding the requirement in terms of mechanical performance.

Stainless steels used for bridges and footbridges belong primarily to two categories of stainless: austenitics and austeno-ferritics, also known as duplex, which combine excellent corrosion resistance and elevated mechanical performance.

More rarely, and for specific applications, certain grades of ferritic stainless are employed.

Table of grades suited to bridge and footbridge applications, classified according to their degree of corrosion resistance			
European standard	US/ASTM standard	Category	Environmental resistance
1.4462	S32205	duplex	highly corrosive (marine and industrial)
1.4404	316L	austenitic	highly corrosive
1.4401	316	austenitic	corrosive to highly corrosive
1.4362	S32304	duplex	corrosive
1.4062	S32202	duplex	corrosive to slightly corrosive
1.4307	304L	austenitic	slightly corrosive
1.4301	304	austenitic	slightly corrosive
1.4618	17-4Mn	austenitic	slightly corrosive
1.4003		ferritic	non-corrosive
1.4017		ferritic	non-corrosive



Cala Galdana Bridge, Menorca

Cala Galdana Bridge, Menorca, Spain, 2005

- A road bridge with two self-anchored arches in 2205 (1.4462) duplex stainless steel
- Technological innovation and durability

The length of the structure is 55 m, with a free span of 45 m. It comprises two carriageways each 3.5 m wide and a 2 m wide walkway on each side. Two parallel arches with an intermediate deck constitute the main structure, entirely built of 2205 (1.4462) duplex stainless plate in thicknesses of 10 to 25 mm according to the component. The arches consist of triangular box girders with a central web and rise 6 m to the apex. They are connected to the two longitudinal rectangular box girders of the deck. The framework components were assembled into structural elements and then transported to the site in eight sections for welding in situ. The finish is obtained by shotblasting the surfaces. In addition to a corrosion-resistant material being dictated by the saline atmosphere, the choice of stainless steel satisfies the criteria of environmental friendliness, great durability, minimal maintenance and technological sophistication.

Design: **Pedelta**  
 Steel construction: **Ascamon**  
 Contracting authority: **Consell Insular de Menorca**

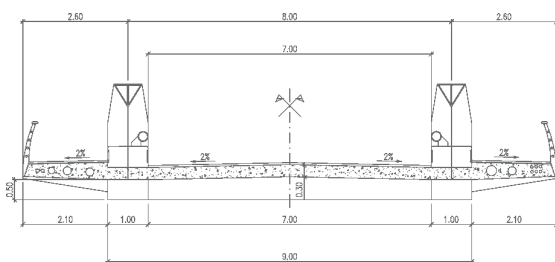

Cross section

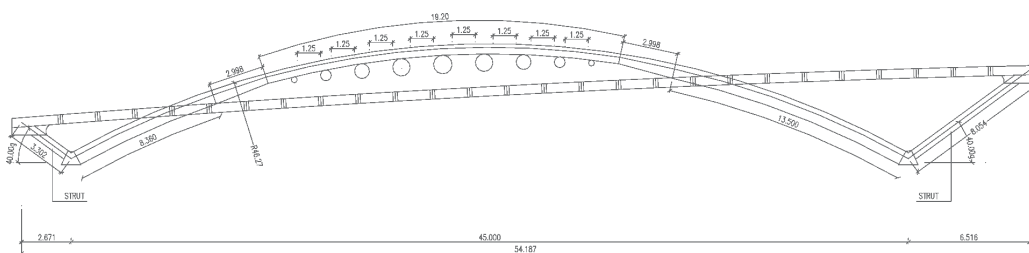

Bridge elevation

# Stainless steel in bridge and footbridge applications



Waldeck-Rousseau Bridge at Saint-Brieuc

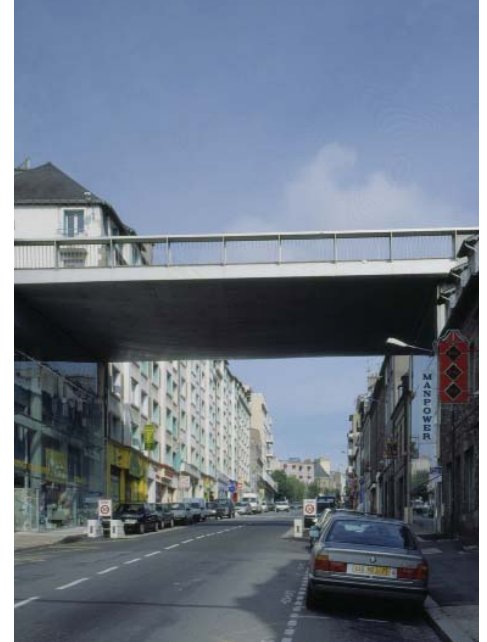

## Waldeck-Rousseau Bridge at Saint-Brieuc, France, 1998

- **Urban road bridge, 316L (1.4404) and 304 (1.4301) stainless steel box girder deck**
- **Reduced cost of maintenance, corrosion resistance**

It is one of the first road bridges, if not the first, to be built with a stainless steel structure. 18 m wide and with a 40 m span, it comprises a central stainless steel span between two reinforced concrete spans and has an asphalt surface. The structure is designed like a steel pillow, stretched

beneath the road, whose dual curvature produces maximum inertia at the centre. The more exposed external plates are in 316L (1.4404) stainless steel, while the interior of the deck is in 304 (1.4301) stainless. All the steel components were joined by welding. Stainless steel's corrosion resistance was a determining factor in the choice of this material, as was the prospect of substantial maintenance savings.

Architects: **Jean Guervilly (DGB)**  
 Consulting engineers: **Groupe Alto/Marc Malinowsky**  
 Steel construction: **Saint-Malo Naval**  
 Contracting authority: **ville de Saint-Brieuc**

## Austenitic stainless steels

They contain nickel and/or manganese and/or molybdenum. This is where one finds the alloys containing the most nickel (up to 13%), which enhances resistance to so-called crevice corrosion and makes the stainless steel more ductile. The most-used grades in the market segment in which we are interested here are 304 (1.4301) and 316L (1.4404) but 304L (1.4307) and 316 (1.4401) are also encountered. Grade 17-4Mn (1.4618), a low-nickel austenitic in ArcelorMittal's "200 series", is also suited to a slightly corrosive environment.

All these grades have similar mechanical properties with a tensile strength  $R_m = 620$  to  $670$  MPa and a yield strength  $R_{p0.2} = 310$ - $330$  MPa for coils and a tensile strength  $R_m = 500$  to  $600$  MPa and a yield strength  $R_{p0.2} = 200$ - $250$  MPa for plates.

The choice between these grades is made according to the structure's environment, in particular atmospheric quality (pollution, sea air, thermal cycle, precipitation). So, in a relatively pollution-free rural environment, one can opt for 17-4Mn (1.4618) stainless, whereas by the coast one will choose 316L (1.4404) stainless.

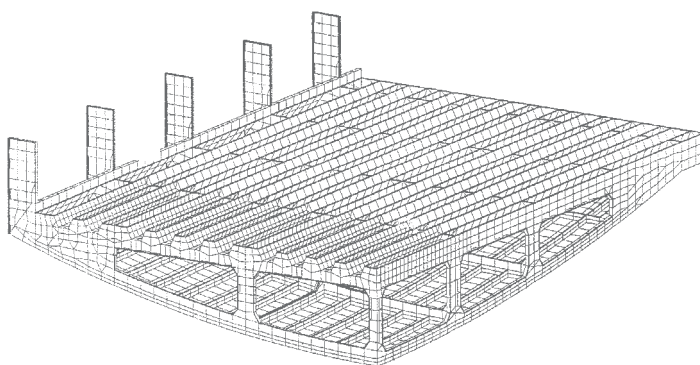

Cutaway axonometric projection of the steel structure of the deck



Pieve di Sacco Bridge, Padua



It is possible to combine these grades, keeping the most corrosion resistant grade for those parts exposed to the open air and a less resistant grade for the internal parts of the structure. This is the solution adopted for the Waldeck-Rousseau bridge at Saint-Brieuc, which combines 316L (1.4404) stainless and 304 (1.4301) stainless.

#### Austeno-ferritic or duplex stainless steels

Duplex stainless steels are characterised by a dual-phase austenite and ferrite structure. Their low percentage nickel content makes them a very competitive material.

ArcelorMittal advocates three grades for bridges:

- 2205 (1.4462) duplex – 22% Cr, 5% Ni;
- 2304 (1.4362) duplex – 23% Cr, 4% Ni;
- 2202 (1.4062) duplex – 22% Cr, 2% Ni.

These grades have the characteristic of combining elevated mechanical properties with corrosion resistance that is often similar or even superior to that of austenitics. In terms of mechanical properties for flat products, tensile strengths ( $R_m$ ) of 840 MPa and yield strengths ( $R_{p0.2}$ ) of 620 MPa are achieved on coils, and 650–750 MPa and 450–550 MPa respectively on plates.

While the processing of duplex appears more complicated than that of austenitic stainless, its mechanical qualities enable the use of thinner plate thicknesses than those used for other stainless steels.

In terms of corrosion resistance, 2202 (1.4062) duplex is positioned between the 304 (1.4301) and 316L (1.4404) austenitics, 2304 (1.4362) duplex is equivalent to 316L (1.4404) and 2205 (1.4462) duplex, which contains 3% molybdenum, has even greater performance. The choice between these grades is influenced by the structure's environment and the construction methods employed in erecting the structure.

#### Ferritic stainless steels

They correspond to ArcelorMittal's Kara range. Two grades – K03 (1.4003) and K31 (1.4017) – are apt to be used in crossing structures. The tensile strengths ( $R_m$ ) of K03 and K31 are 510 MPa and 650 MPa respectively and their yield strength ( $R_{p0.2}$ ) is 370 MPa. Easily weldable, these stainless steels are grades that can be used bare (K31 in a non-corrosive atmosphere) or painted or coated to further enhance their longevity (K03/K31). In certain carefully selected cases, this category of stainless steel is very competitive.

Pieve di Sacco Bridge, Padua, Italy, 2006

- Dual-arch road suspension bridge in 2304 (1.4362) duplex stainless steel
- Durability and reduced maintenance

To span the 120 m distance, the deck is supported by two 1300 mm diameter arches made of 12 to 26 mm thick 2304 (1.4362) duplex stainless steel plate; this represents 110 tonnes of stainless steel. The deck beams are 1000 mm high double-T welded plate beams in steel grade S355 (250 t) in conjunction with a composite deck and casing in 304 (1.4301) stainless steel.

Architects: **Progeest / Enzo Siviero**  
 Design engineers: **Provincia de Padova / Silvio Collazuol**  
 Execution design engineer: **TreEsse / C. Berto; Seteco ingegneria / Pierangelo Pistoletti** (structures)  
 Steel construction: **Castalvo**  
 Contracting authority: **province of Padua**



# Stainless steel in bridge and footbridge applications



Simone-de-Beauvoir Footbridge, Paris



## Simone-de-Beauvoir Footbridge, Paris, 2006

- Steel footbridge, with 316L (1.4404) stainless steel guardrails
- Slenderness and strength

The Simone-de-Beauvoir footbridge is a new crossing in Paris, suspended above the Seine between the French National Library and the Bercy gardens. The elegant footbridge undulates with a gentle rhythm. It is bordered by guardrails comprising stainless steel mesh – visible and reassuring but nevertheless transparent – installed between the handrail and a stainless steel tube near deck level. The cable mesh stretches between two rails, upper and lower, in the form of tube, all in 316L (1.4404) stainless steel. Here, the stainless steel components combine slenderness and strength.

Architects: **Dietmar Feichtinger**  
Consulting engineers: **RFR, structural designer**  
Steel construction: **Eiffel construction métallique**, main contractor; **Joseph-Paris**  
Contracting authority: **mairie de Paris**

## Which products for which applications?

Stainless steel can be found in all or part of a bridge or footbridge. It is commonly used in protection components – handrails and guardrails – as well as in the stays of suspension bridges, cables and tie-rods. It is also advocated for the deck and anchorage components, particularly in the case of structures built in marine and polluted atmospheres. It is produced in the form of bars, wire, rod, sheet and plate, as well as finished products such as tubes and concrete reinforcement.

### Tubes and grilles

Handrails and guardrails – made of tube, sheet, expanded metal, perforated metal or woven wire – are very often produced in stainless steel and the most commonly used grade is 316L (1.4404) in the austenitic category. For these applications, this grade has the advantage of offering excellent resistance to corrosion and other attacks, even in thin gauges of steel. Its uniform appearance does not deteriorate, it is smooth and soft to the touch. Lastly, it is simple to clean.

### Plates and welded plate sections

There is a great variety of bridges and footbridges; they represent a wide range of constructional designs. However, the most-used stainless steel product in the execution of these structures is plate. Relatively easy to process, it enables the production of welded plate sections and box girders. Thus, plates welded together will take the form of a barrel arch here, of a pillow there, of a triangular box girder elsewhere, of a castellated beam or even of a skin.

The components are cut, bent, formed, welded, finished, largely in workshops using specialist tools and techniques. Plates are generally arc-welded and the welds are then cleaned and descaled. The formed components are transported to the site for assembly and erection.

### Cables, stays and tie-rods

Suspension and load transfer components, they also provide for the tensioning of the structure. As in the case of plate, stainless steel's corrosion resistance and its mechanical performance are essential, particularly in the case of structures in marine and polluted atmospheres. The use of stainless steel also enables construction using relatively thin components.





Saint-Lô Footbridge, France



Granite Footbridge, la Défense

### Saint-Lô Footbridge, France, 2001

- Footbridge with carbon steel structure and stainless steel formwork
- Competitive cost and uniformity of appearance

The construction of this footbridge forms part of a larger redevelopment project on the banks of the River Vire. It establishes a 67 m pedestrian crossing – with a 51 m span between the supports of the main arches – thus connecting the station to the town centre. Its structure consists principally of two inclined arches and two tubular stringers interconnected by IPE 220 beams. These beams support the concrete slab poured into 0.60 mm thick grade 304 (1.4301) stainless steel permanent formwork. The entire steel structure, including the stainless steel formwork, is painted in white enamel, thus preventing direct contact between the two types of steel.

The choice of stainless steel was guided here by the need in this location for a corrosion-resistant material at competitive cost. Furthermore, it offered a perfect finish on the lower face.

Landscape architect: **François Brun**  
 Consulting engineers: **Terrell Rooke associés / Zbigniew Koszut**  
 Steel construction: **OMS**  
 Contracting authority: **Saint-Lô conurbation**

### Granite Footbridge, la Défense, France, 2007

- Suspended steel footbridge, cables, stays and handrail in 316L (1.4404) stainless steel
- Strength and slenderness

In this footbridge, 316L (1.4404) stainless steel is employed in structural components and safety components (handrail, lift gate). Comprising twenty-six carbon steel box girders, the deck, once raised, was pre-stressed by tensioning stainless steel cables and stays; three ground supports anchor the structure.

The footbridge, which is 90 m long and 4.5 m wide, forms a curve at the second-floor level of the Granite tower. It thus provides a unique walkway, suspended among the towers. Complemented by vertical circulations, it connects the slab to the town's natural ground level.

Architects: **Dietmar Feichtinger**  
 Consulting engineers: **Schlaich Bergemann und Partner**  
 Steel construction: **Viry**  
 Contracting authority: **EPA Seine-Arche**

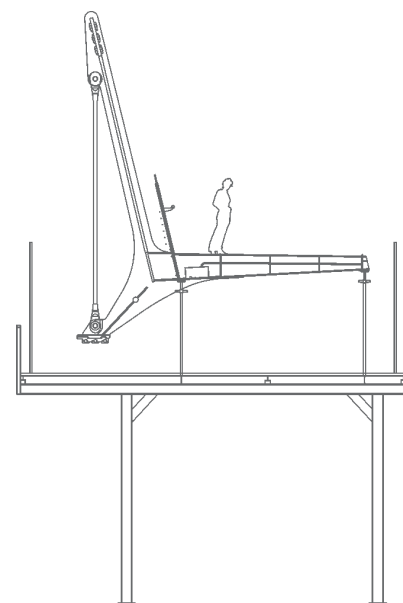

Cross section

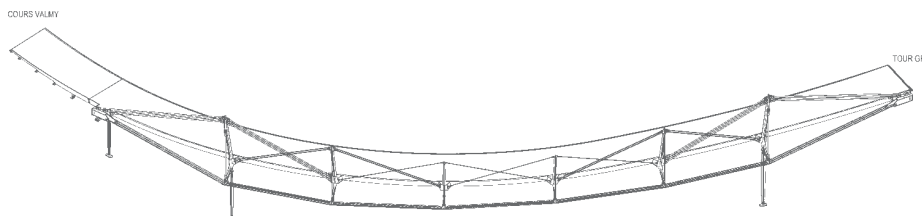

Perspective view

# High-performance design and efficient execution



Pedro Arrupe Footbridge in Bilbao



## Pedro Arrupe Footbridge in Bilbao, Spain, 2003

- Box girder structure footbridge in 2304 (1.4362) duplex stainless steel
- Corrosion resistance and aesthetic quality

Located in Bilbao's flagship district, close to the Guggenheim museum, the Pedro Arrupe Footbridge has the appearance of being built entirely of stainless steel as much in order to satisfy aesthetic considerations as to withstand the salinity of the Bay of Biscay. The deck is designed as an open box girder, constructed of 20 mm thick 2304 (1.4362) duplex stainless steel plates bent into a "U" shape, inside which the internal frame made of weathering steel is located. The combination of these two steels required particular care. The transverse bracing frames support the concrete slab poured into galvanised steel forms. The entire deck is clad with Lapacho, a Brazilian wood. The structure is 142 m long between abutments and comprises a central span and four pairs of ramps.

Architect: **Estudio Guadiana / Lorenzo Fernández Ordóñez**

Structural designer: **Ideam**

Steel construction: **UTE Ferroviál-URSA**

Contracting authority: **Bilbao Ria 2000**



## Technical characteristics and aesthetic quality of structures

Corrosion resistance, very good tensile strength, high yield strength: the choice of stainless steel is a guarantee of quality with regard to bridge construction. Its properties enable compliance with the most demanding technical requirements: long span, lightweighting of structures, seismic performance. It can be used bare, even in very harsh environments such as coastal or industrial zones. Its Young's modulus-to-density ratio makes it possible to combine lightness and rigidity and thus give birth to slim, slender structures. The benefits arising from the use of this material also frequently engender major savings that ultimately can be offset against its capital cost.

## Speed of execution and economical construction

To a great extent, stainless steel components are prefabricated and assembled in workshops, then transported to the site for erection in situ. They offer the advantage of precise execution, computer-controlled from the design of the component through to final assembly, which shortens and simplifies the sitework phase and enables better control of the construction timetable. The inconvenience caused by the construction operation is reduced and there is less disruption to traffic. The erection of the Charvaux footbridge, for example, lasted two weeks and was performed alongside the old footbridge that it replaced. The crossing was kept open at all times and the disruption caused lasted only a short time.



Charvaux Footbridge, Andrésey

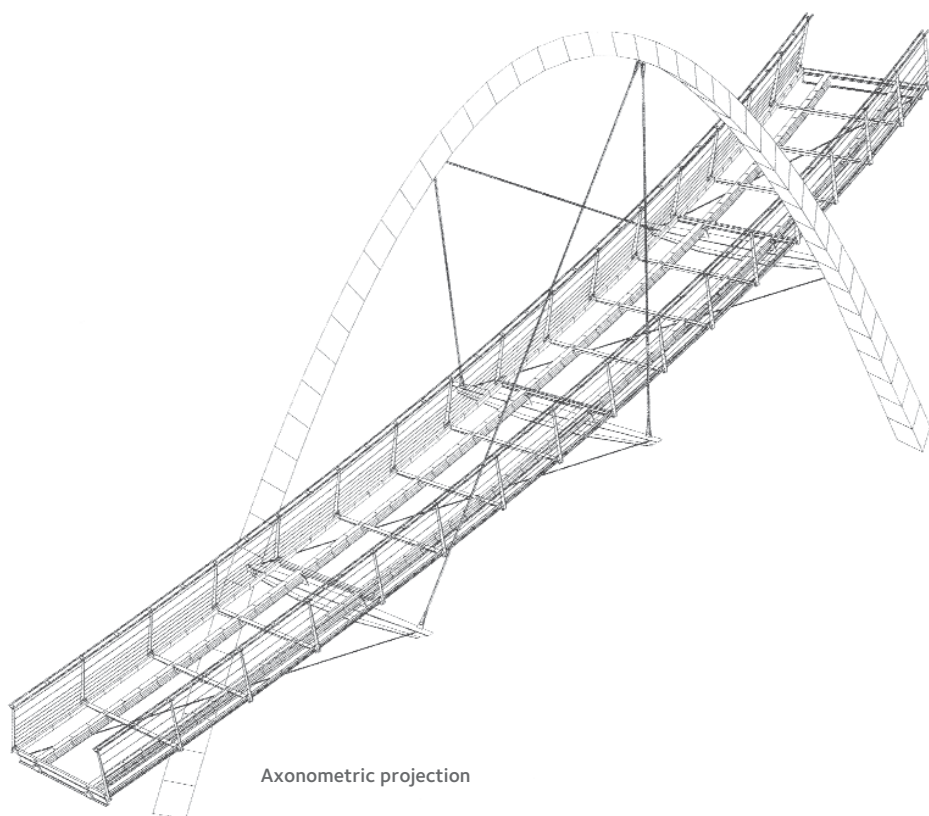

Axonometric projection

Charvaux Footbridge, Andrésey,  
France, 2000

- Single-arch suspended footbridge in 316 (1.4401) stainless steel
- Maintenance savings, longevity and uniform appearance

The Charvaux footbridge replaced a dangerous dilapidated footbridge. It spans 33 m above a busy road to connect two districts. Its structure, consisting entirely of passivated satin-finish 316 (1.4401) stainless steel, comprises a triangular section variable inertia parabolic arch and cross-bracing stays supporting the footbridge's curved deck by way of three transverse beams; bracing cables installed beneath the deck balance the loads. The arch and the deck provide horizontal stability. The deck comprising cross beams and longitudinal girders is covered with Ipe wooden decking; it was manufactured in four sections in a production shop and then assembled in situ. The bridge was erected over a period of a fortnight. The stainless steel solution was selected in conjunction with the town council, for reasons of longevity and minimal maintenance. Moreover, it affords the structure a uniform appearance as all of the components, including the guardrail fittings, are in stainless steel.

Architects: **Hubert & Roy / Michel Roy**  
 Consulting engineers: **Groupe Alto / Marc Malinowsky**  
 Steel construction: **OMS**  
 Contracting authority: **Andrésey town council**

## Longevity and reduced maintenance

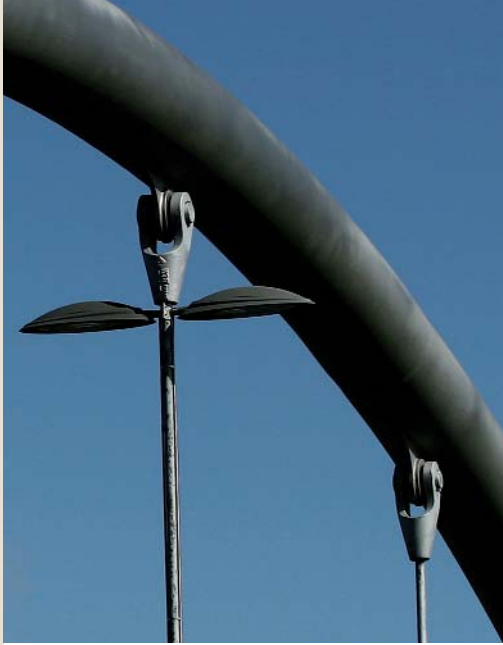

Arco di Malizia Bridge, Siena

Arco di Malizia Bridge, Siena,  
Italy, 2005

- Single-arch road suspension bridge in 2304 (1.4362) duplex stainless steel
- Durability and reduced maintenance

This 15.8 m wide road bridge spans 51.5 m. Its weathering steel deck is suspended from a centrally-positioned longitudinal arch, which thus separates the opposing traffic flows.

This arch consists of five cylindrical elements, 10.7 m long and 820 mm outside diameter. They are produced from 35 mm thick 2304 (1.4362) duplex stainless steel plate, longitudinally arc-welded and formed. Pre-assembly of the five elements was performed on site by arc-welding, prior to erection. Two shotblasting operations, in the production shop and then in situ, ensure a flawless finish.

Architect: **Paola D'Orsi**  
Design engineers: **Raffaello Fontani**  
Execution design engineer: **Seteco ingegneria / Pierangelo Pistoletti**  
Contracting authority: **Siena city council**

### An enduring material

Stainless steel's strength is a guarantee of longevity. Neither its mechanical properties nor its appearance deteriorate. It withstands heavy loads and, to a certain extent, vibrations, impacts and elevated tensile stresses.

The risks of deterioration of the material are very low in the case of normal use. With regard to ad hoc maintenance operations, however, it must be ensured that the use of certain products such as road salt or maintenance products containing chlorine is compatible with the selected grade of stainless steel.

### Minimal maintenance

Stainless steel's natural corrosion resistance and its mechanical properties considerably reduce maintenance operations and by extension their cost during the structure's operating life. This advantage is essential, particularly in the case of long-span bridges, equipped with tall masts, where inspection and access to components are sometimes extremely difficult. On more traditional structures, the benefit is still significant: renovating or repainting all or part of a bridge normally requires that traffic flows on the bridge be suspended or subject to major restrictions. Reducing this type of operation as much as possible is essential, particularly at crossings that already naturally constitute traffic choke points.

In the case of Stonecutters Bridge, the structure's longevity has been assessed as 120 years without any maintenance operation on the stainless steel components; this criterion carries great weight in the choice of material.



## An economic solution



Stonecutters bridge à Hong Kong.



A bridge or a footbridge is a major investment. However, the expense of its construction and maintenance will vary according to the materials chosen for its design and construction.

Analysis of the cost of such a structure is only meaningful if it includes all costs related to its construction, its operation and its deconstruction, over its entire lifetime, which in the case of bridges and footbridges should exceed 100 years.

In the case of stainless steel, this approach compensates for the higher capital cost linked to the choice of material: ultimately, it is offset, in whole or in part, by the benefits obtained in operation.

Furthermore, in cases in which project funding is particularly tight, it is always possible to restrict the use of stainless to external parts and to use a carbon steel for the internal, and therefore protected, parts. This is the choice that was made for the Pedro Arrupe footbridge in Bilbao, whose structure consists of carbon steel. This hybrid solution enables the initial construction cost to be reduced. It simply requires some precautions in design and construction: the two types of steel must never, under any circumstances, come into direct contact and access to the structure's internal parts must be possible in order to conduct regular inspections.



Stonecutters Bridge, Hong Kong



Stonecutters Bridge, Hong Kong, China, 2010

- Cable stayed highway bridge using stainless steel on the towers. Below deck level outer layer of concrete reinforcement is 304 stainless steel (1.4301). The upper part of the tower is a composite structural section using an inner concrete core and an outer 2205 duplex stainless steel skin (1.4462).
- Reduced maintenance, corrosion resistance, economical

This highway bridge due for completion in 2010 forms part of the route connecting Tsing Yi and Cheung Sha Wan. It is a cable-stayed bridge employing a semi-fan cable configuration, it extends for a length of 1596 m with a 1018 m main span between two immense masts that rise 296 m above sea level, of which more than 200 m is above deck level. The upper 120 m of these conical masts is a composite structural section of an inner reinforced concrete core and an outer skin of 20 to 25 mm thick 2205 (1.4462) duplex stainless steel plates. In the lower part of

the tower (below deck level) the concrete reinforcements are in 304 (1.4301) stainless steel. The skin is structural, since it contributes to the distribution of loadings between the masts and the foundations. The choice of 2205 (1.4462) duplex stainless steel to clad the masts satisfies a dual technical and economic requirement: built for a service life of at least 120 years, a material that is both long-lasting and maintenance-free was essential. This skin must withstand particularly high loads principally due to winds because the structure is in a typhoon belt. The polluted marine atmosphere called for a highly corrosion resistant stainless steel. Finally, the uniform matt finish specified is obtained by beadblasting the plate. To date, it is the world's largest use of stainless steel for this type of structure.

Design: **Dissing+Weitling arkitektfirma a/s, Flint & Neill Partnership, Halcrow Group, Shanghai construction engineering group**  
 Detailed structural design: **Arup**  
 Contracting authority: **Hong Kong Department of Highways**

# Environmental considerations

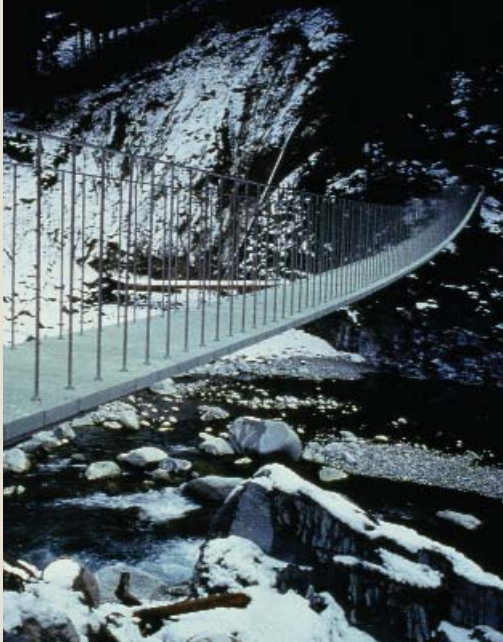

Suransuns Footbridge

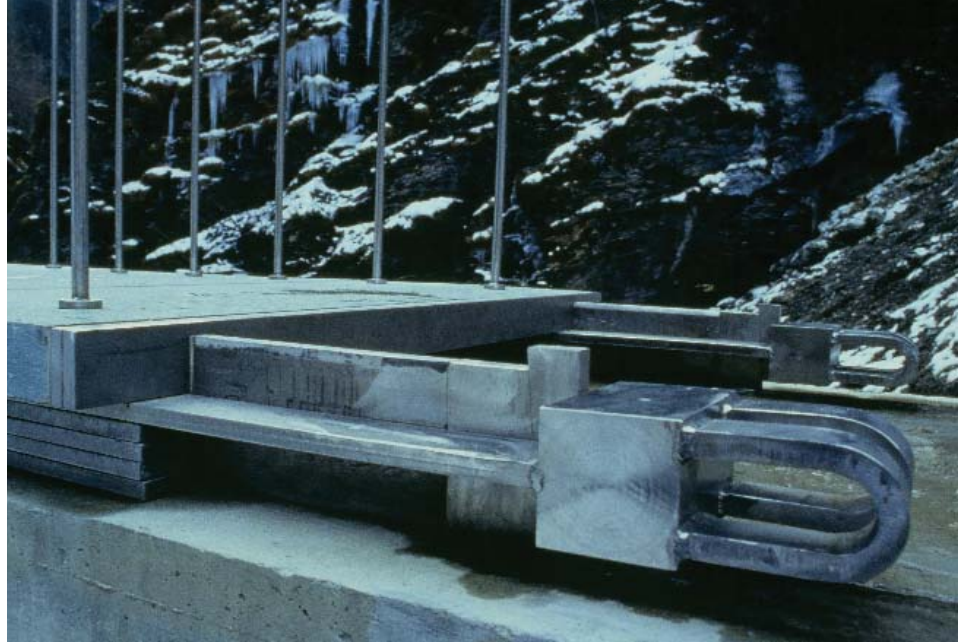

Suransuns Footbridge, Switzerland, 1999

- Stress ribbon footbridge in 2205 (1.4462) duplex stainless steel and 316L (1.4404) stainless steel
- Corrosion resistance, slenderness and simplicity

The Suransuns footbridge provides a continuation of the ancient Roman Via Mala in the form of a flexible, slender ribbon, connecting the two sides of the gorge at the bottom of which flows the Hinter Rhine: 40 m span. It consists of four 2205 (1.4462) duplex stainless steel ribbons, joined in pairs by means of straps in the same steel. A guardrail post, a 16 mm diameter 316L (1.4404) stainless steel tube that also secures the natural stone decking through which it passes, is bolted to each strap; a flat welded to the upper end of the tubes forms the handrail. Concrete abutments on each side of the gorge provide for anchorage and tensioning of the structure by means of tension rods. The stainless steel grades selected withstand salt spray from the nearby main road. The steel, stone and concrete harmonise with the landscape.

Architect: **Jürg Conzett**  
Consulting engineers: **Conzett, Bronzini, Gartmann AG**  
Steel construction: **Romei**  
Contracting authority: **Verein KulturRaum Via Mala**

Environmental issues now constitute some of the parameters that must be considered in any construction project, including bridges.

## Reduced consumption of materials

The method of designing and manufacturing steel components – computer-aided design and workshop prefabrication – optimises the quantity of material used and generates a minimum of waste which, moreover, is recovered and recycled. The high performance afforded by stainless steel's mechanical properties renders it a graceful, lightweight solution.

## Environmentally friendly

Stainless steel is an environmentally inert material: in particular, it does not release any element that could harm its environment. Being rust-resistant, it does not require any special maintenance, unlike a painted material, which must regularly be stripped and repainted: two operations that are liable to pollute the rivers being crossed or the surrounding air.

## Recyclable and recycled

All ArcelorMittal stainless steels are produced through the electric-arc process, 100% from recycled scrap. A material that is totally recyclable at the end of its life, it is extensively recycled. All ArcelorMittal Stainless Steel Europe, ArcelorMittal Industeel and ArcelorMittal Stainless Tubes Europe production plants operate under the ISO 14001 standard.



# Architectural freedom



Marina Bay Pedestrian Bridge, Singapore



## Marina Bay Pedestrian Bridge, Singapore, 2009

- Tubular structure footbridge in 2205 (1.4462) duplex
- Corrosion resistance, aesthetic quality, innovation

The structure of the Marina Bay Pedestrian Bridge consists of a reverse double helix – symbolising a DNA molecule – that supports the footbridge and defines its volume. The two spirals constructed of 2205 (1.4462) duplex stainless steel tubes are interconnected, creating a sort of tubular lattice girder, thus distributing loadings. The deck is inserted into this structure. Five platforms punctuate the footbridge, providing viewpoints looking across the bay.

The 280 m long walkway is partially protected from sun and rain by the provision of a steel and glass mesh canopy.

Architects: **Cox Group + Architects 61**  
 Consulting engineers: **Arup**  
 Steel construction: **TTJ Design & Engineering**  
 Contracting authority: **Urban redevelopment authority of Singapore**

## Inspirational

Steel in general, and stainless steel in particular, is often appreciated for the freedom of form that it enables. It permits bold innovation that is often of value in resolving project-related constraints. For example, the Charvaux footbridge is a functional solution that is both economical and innovative; as is the Stonecutters Bridge, in a very different register, with its conical masts clad in stainless steel over a height of more than 100 metres.

Furthermore, stainless steel is easily combined with other materials: whether it be the timber that is often found as decking on footbridges – those of Bilbao and Charvaux are examples – or stone, as at Via Mala, or even concrete and asphalt in the case of road bridges. Other steels are not excluded, as witness the galvanised steel gratings of the Chécý footbridge or the carbon steel main structure of the Saint-Lô footbridge.

Lastly, stainless steel offers a high-quality appearance and a wide range of surface finishes, from matt to bright, as-rolled to mirror, that should be appraised on the basis of each type of component.

## In harmony with the landscape

The visual unobtrusiveness that steel can confer favours the integration of the structure into the landscape in which it is employed, particularly in respect of the framework. The Via Mala suspension footbridge in Switzerland – a simple ribbon between two banks – illustrates this perfectly.

## ArcelorMittal's offer

### ArcelorMittal Stainless Europe

Automotive & Industry Division  
(Sheets, flat products)  
Tel.: +32 89 30 19 66  
Fax: +32 89 30 19 07  
Contact: marian.stinckens@arcelormittal.com  
www.arcelormittal.com/stainlesseurope

### ArcelorMittal Stainless Europe

Specialities Division  
(Sheets, flat products)  
Tel.: +33 (0)3 85 85 75 39  
Fax: +33 (0)3 85 85 79 55  
Contact: olivier.caillaud@arcelormittal.com  
www.arcelormittal.com/stainlesseurope

### ArcelorMittal Ancerville

Stainless Tubes Europe  
(Tubes)  
Tel.: +33 (0)3 29 79 90 25  
Fax: +33 (0)3 29 79 90 40  
Contact: marc.nicolas@arcelormittal.com  
www.arcelormittal.com/stainlesstubeurope

### ArcelorMittal Industeel

(Thick sheets)  
Tel.: +32 499 56 40 40 / +33 (0)3 85 80 58 51  
Fax: +33 (0)3 85 80 51 77  
Contacts: pierre.souignac@arcelormittal.com /  
b.vincent@arcelormittal.com  
www.industeel.info

### ArcelorMittal Distribution (AMD)

Tel.: +33 (0)3 26 84 67 02  
Fax: +33 (0)3 26 84 67 09  
Contact: Nicolas.aublanc@arcelormittal.com  
www.arcelormittal.com/distribution

## For further information

### ArcelorMittal

Building & Construction Support  
Tel.: +33 (0)1 71 92 16 86  
Fax: +33 (0)1 71 92 24 97  
www.arcelormittal.com

### Constructalia

Email: contact@constructalia.fr  
www.constructalia.com

### Websites

www.euroinox.org  
www.worldstainless.org

### Publications

- ArcelorMittal, Building & Construction Support Stainless Steel in Construction, 2007
- ConstruirAcier (ex-Otua), Puteaux, France Bulletins Ouvrages métalliques n° 2 (2002), n° 3 (2004) et n° 4 (2005)
- Euro inox, Bruxelles, Belgique Pedestrian Bridges in Stainless Steel, circa drei, Munich (Allemagne), 2004
- 30 Bridges, Matthew Wells, Laurence King Publishing, London, UK, 2002

COURS VALMY



SECCIONES TRANSVERSALES TIPO E: 1/50

SECCION RAMPA CENTRAL

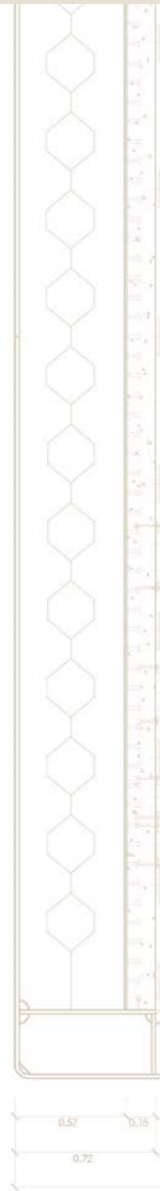

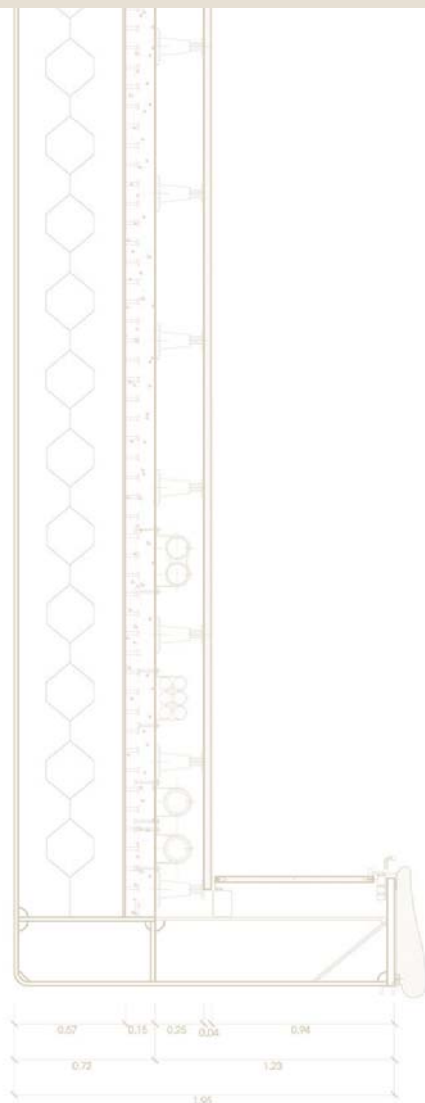
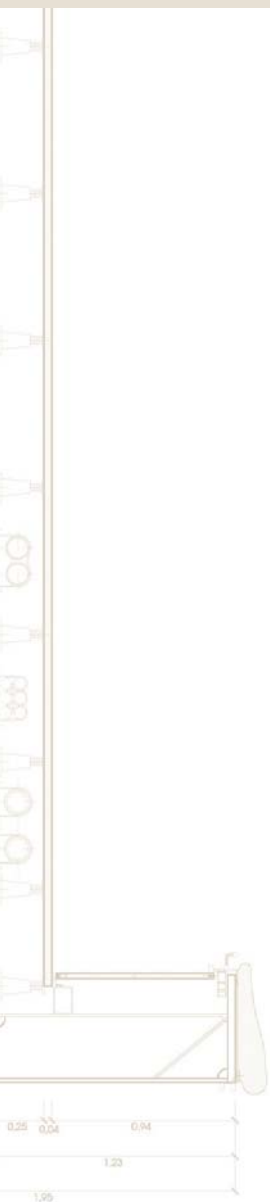

SECCION RAMPAS CENTRAL

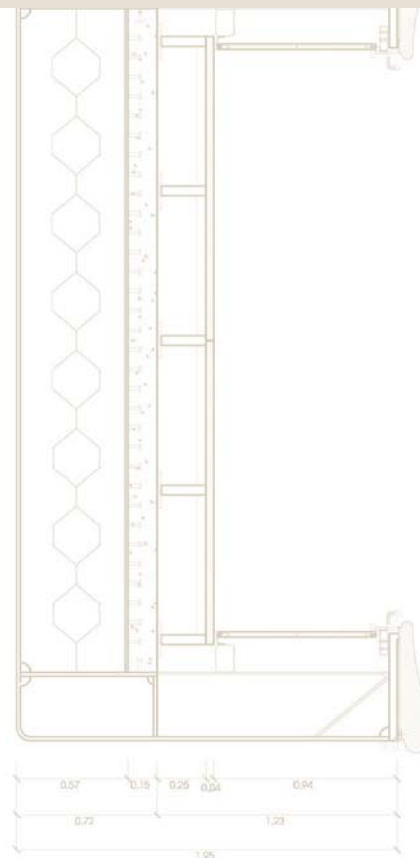

SECCION RAMPAS LATERALES

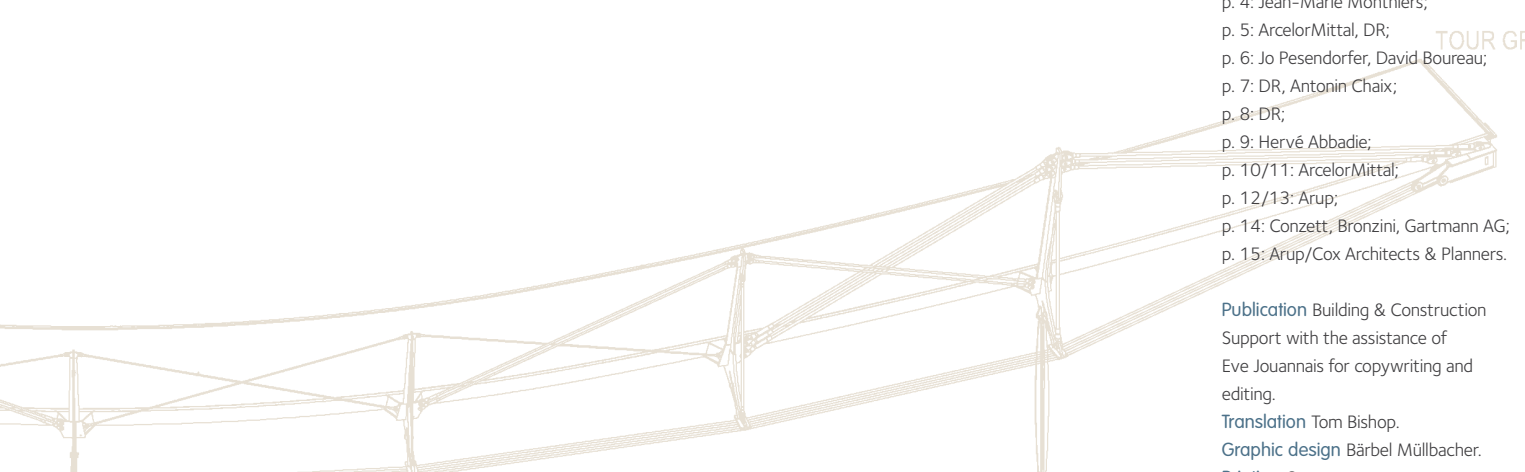

**Photo credits**

- cover: Pont Arco di Malizia à Sienne, © ArcelorMittal;
- p. 1: Pünt da Suransuns, © Conzett, Bronzini, Gartmann AG;
- p. 2: Brigit de Kosmi;
- p. 3: DR;
- p. 4: Jean-Marie Monthiers;
- p. 5: ArcelorMittal, DR;
- p. 6: Jo Pesendorfer, David Boureau;
- p. 7: DR, Antonin Chaix;
- p. 8: DR;
- p. 9: Hervé Abbadie;
- p. 10/11: ArcelorMittal;
- p. 12/13: Arup;
- p. 14: Conzett, Bronzini, Gartmann AG;
- p. 15: Arup/Cox Architects & Planners.

Publication Building & Construction Support with the assistance of Eve Jouannais for copywriting and editing.  
 Translation Tom Bishop.  
 Graphic design Bärbel Müllbacher.  
 Printing Qatena.

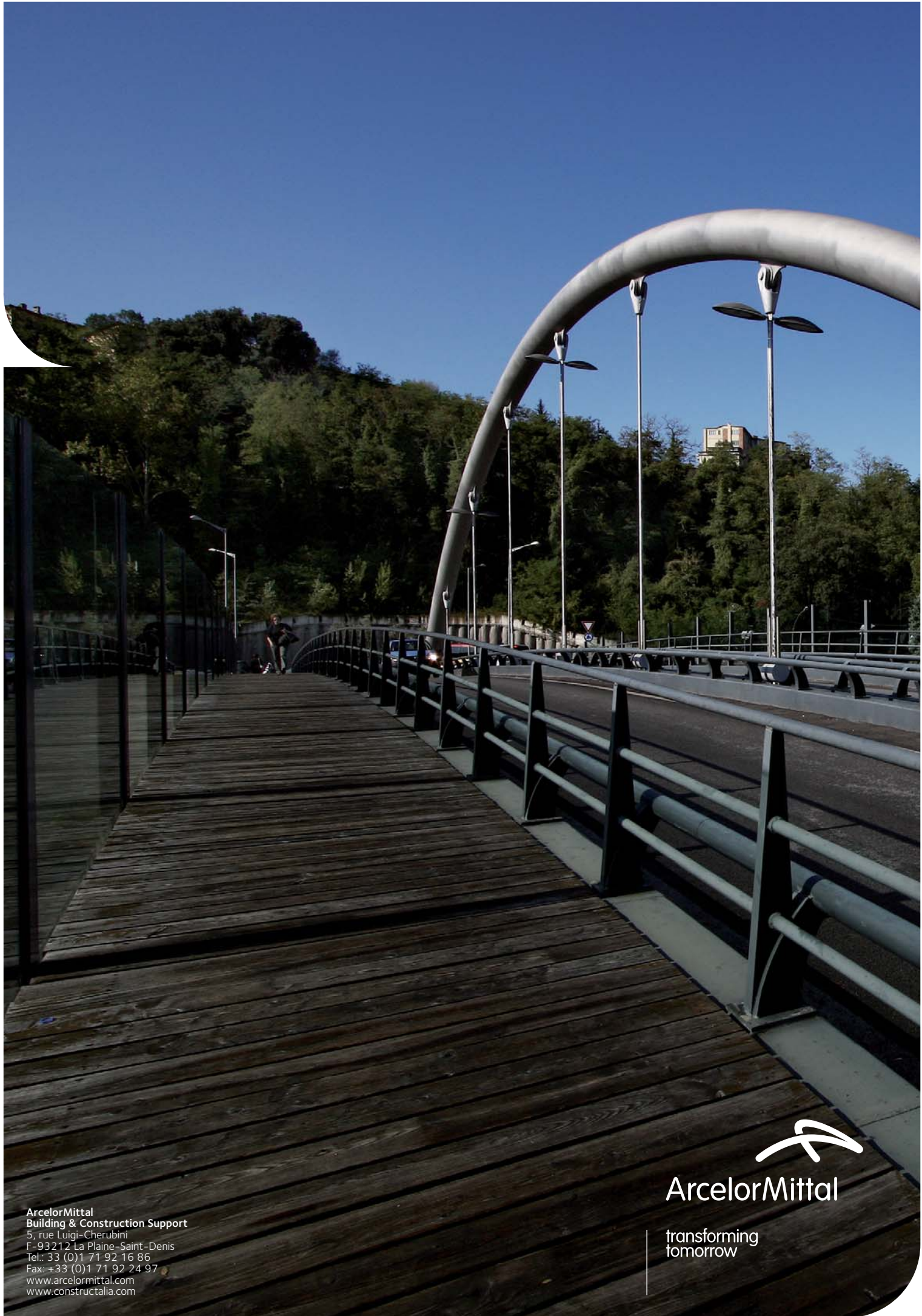

ArcelorMittal  
Building & Construction Support  
5, rue Luigi-Cherubini  
F-93212 La Plaine-Saint-Denis  
Tel.: 33 (0)1 71 92 16 86  
Fax: +33 (0)1 71 92 24 97  
[www.arcelormittal.com](http://www.arcelormittal.com)  
[www.constructalia.com](http://www.constructalia.com)

  
ArcelorMittal

transforming  
tomorrow