

GROUND IMPROVEMENT USING THE VIBRO-STONE COLUMN TECHNIQUE

Bryan A. McCabe BA BAI PhD CEng MIEI

Lecturer, Department of Civil Engineering, National University of Ireland, Galway.

James A. McNeill BSc MSc CGeol FGS

Regional Manager, Keller Ground Engineering, Belfast.

Jonathan A. Black BEng PhD MICE

Lecturer, School of Engineering, University of Plymouth.

Paper presented to a joint meeting of Engineers Ireland West Region and the Geotechnical Society of Ireland, NUI Galway, 15th March 2007



ABSTRACT: The Vibro Stone Column technique is one of the most widely-used ground improvement processes in the world, although its potential for improving Irish sites has yet to be fully exploited. Historically the system has been used to densify loose granular soils, but over the past 35 years, the system has been used increasingly to reinforce soft cohesive soils and mixed fills. This paper will describe the technique, applicable soil types, settlement and bearing capacity calculations, recent research areas and an Irish case study.

1. INTRODUCTION

Vibro-Flotation is a collective term for forms of ground improvement brought about by inserting a vibrating poker into the ground, and includes Vibro-Compaction and Vibro-Replacement. The latter process is often referred to as (Vibro-) Stone Columns. The commercial promise of Vibro-Compaction was realised with German river-borne granular soils in the 1930s, but it was not until the 1960s that Stone Columns were deployed for improving cohesive soils. Stone Columns were first used in Ireland in the 1970s. The technique is continuing to gain popularity today due to the considerable savings to cost and programme schedule that it can offer over conventional piling solutions in many circumstances.

The Vibro-Replacement process is discussed in this paper along with a description of the mechanism of stone column behaviour under load and associated design philosophies. A checklist for the use of stone columns in marginal ground conditions and some practical findings from recent research programmes are also presented. Ample references are provided for those interested in engaging with the topic in more detail.

2. VIBRO-COMPACTION AND VIBRO-REPLACEMENT

Vibro-Flotation is performed with a vibrating poker device which can penetrate to the required treatment depth under the action of its own vibrations, assisted by the pull-down winch facility of the rig. The vibrations imparted to the ground are predominantly horizontal and will increase the relative density of soil if the granular content is greater than $\approx 90\%$ (see Figure 1). This process is referred to as Vibro-Compaction, and has been used to compact loose sands to depths of 30m, such as in The World and Palm Island Projects off the Dubai coast and Edinburgh's Leith Docks.

However, the vibrations themselves have minimal effect on cohesive soils (clays and silts), so in these and mixed soils, the penetration of the poker is followed by the construction of a stone column. The displacement of the existing ground by the penetrating poker allows the construction of granular columns with high friction angle, so that the composite soil mass has a greater

average strength and stiffness than the untreated ground.

The hole created by the poker is filled with inert crushed stone or gravel (or approved construction waste in certain circumstances) and is compacted in stages from the base of the hole upwards. There are two different approaches that may be used to construct the column, depending on the ground conditions. In the Top Feed System, the poker is completely withdrawn after initial penetration to the design depth. Stone (40-75mm in size) is then tipped into the hole in controlled volumes from the ground surface. The column is compacted in layers (the stone is forced downwards and outwards) through continued penetration and withdrawal of the poker. The Top Feed System is suitable if the hole formed by the poker will remain open during construction of the column.

Alternatively, the stone may be fed from a rig-mounted hopper through a permanent delivery tube along the side of the poker, which bends inwards and allows the stone to exit at the poker tip. This Bottom Feed process requires a smaller grade of stone (15-45mm). By remaining in the ground during column construction, the poker cases its own hole and hence is suited to ground with a high water table or running sand conditions. The Bottom Feed system is shown on the cover photograph, with a schematic illustration of the process shown in Figure 2.

In addition to improving bearing capacity and reducing compressibility, stone columns installed in a uniform grid pattern will help 'homogenise' variable soil properties, thereby reducing the potential for differential settlement. Stone columns serve a secondary function of acting as vertical drains, accelerating the dissipation of excess pore water pressures (and associated primary settlement) from the imposed loading, allowing a foundation or floor slab to be brought into service at an early stage. In addition to the savings per metre length that stone columns present over piles, the 'soft' column heads facilitate the use of ground bearing slabs, representing further savings compared to the ground beams and suspended slabs associated with piled solutions.

Plate load tests (typically 600mm diameter) are carried out on constructed columns to verify the compactness of the stone and the stiffness of the supporting ground at the top of the column.

However, settlements measured may not be representative of foundation or slab behaviour due to differences in the load duration and depth to which the ground is stressed. Long term zone load tests provide a truer reflection of the stiffness of the ground, as a plan area the size of a real foundation is loaded which will usually straddle several columns and the intervening untreated ground. However, due to their cost, these are generally reserved for marginal sites.

In addition to these control measures, it should be noted that the vibrating poker itself acts as an investigating tool which provides an additional safeguard against unforeseen ground conditions. A measure of the resistance to penetration of the poker is fed back electronically to the rig operator, who can then match the quantity of stone supplied to the lateral resistance of the ground encountered.

Key publications which illustrate the Vibro-Compaction and Replacement techniques, the importance of good construction practice and some interesting case histories are Slocombe *et al* (2000), Bell (2004) and Sondermann and Wehr (2004).

3. BEHAVIOUR AND DESIGN OF STONE COLUMNS

Most types of ground improvement are intended to work with the existing ground whereas rigid inclusions (piles) are intended to bypass the ground to some extent. While stone columns will transmit some load to the soil by shear stresses (along the column-soil interface) and end bearing (at the column base), the predominant load-transfer mechanism (unless the column is very short) is lateral bulging into the surrounding soil. The relevant column stresses are depicted in Figure 3, while Figure 4 illustrates the bulging phenomenon in model granular column tests in clay carried out at the University of Plymouth. The passive resistance of the surrounding soil dictates the column performance under load. Generally the column bulging will be greatest close to the top of the column where the overburden pressures are lowest.

Cylindrical Cavity Expansion Theory (CCET) is applied to many geotechnical problems, most notably to the interpretation of the pressuremeter test which measures horizontal stresses in the ground (i.e. Wroth, 1984). CCET has also been used to model the bulging behaviour of granular

columns leading to predictions of bearing capacity and settlement performance.

Bearing Capacity

Hughes and Withers (1974) performed pioneering laboratory studies of sand columns within a cylindrical chamber containing clay, and used radiography to track the deformations occurring within and outside the column. They found that CCET represented the measured column behaviour very well, and proposed that the ultimate vertical stress (q) in a stone column could be predicted by:

$$q = \frac{1 + \sin \phi'}{1 - \sin \phi'} (\sigma'_{ro} + 4c) \quad [1]$$

where ϕ' is the friction angle of the stone infill, σ'_{ro} is the free-field lateral effective stress and c is the undrained strength. This equation is widely used in practice today.

There are alternative approaches for estimating the bearing capacity of single columns and column groups, such as that recently published by Etezzad *et al* (2006). The authors report an analytical treatment of bearing capacity failure mechanisms. The failure mechanisms adopted are based upon the output from a combination of Finite Element analyses and field trials.

Settlement

Absolute and differential settlement restrictions usually govern the length and spacing of columns, and the preferred method of estimating post-treatment settlement in European practice was developed by Priebe (1995), again based upon CCET. Although this method is strictly applicable to an infinite array of columns and has some empiricism in its development, it is found to work very well for most applications.

Priebe's settlement improvement factor, n , defined as:

$$n = \frac{\text{settlement without treatment}}{\text{settlement with treatment}} \quad [2]$$

is a function of the friction angle of the stone ϕ' , the soil's Poisson's ratio and an Area Replacement Ratio dictated by the column spacing. The area replacement ratio is defined as A_c/A , where A_c = cross-sectional area of one

column and A = total cross-sectional area of the ‘unit cell’ attributed to each column (see Figure 5). A_c/A is related geometrically to the column radius (r) and column spacing (s) according to:

$$\frac{A_c}{A} = k \left(\frac{r}{s} \right)^2 \quad [3]$$

where k is π and $2\pi/\sqrt{3}$ for square and triangular column grids respectively. Beneath footings and strips, it is usually sufficient to determine A_c directly as the total foundation area divided by the number of supporting columns.

Priebe’s ‘basic improvement factor’ may be derived from the chart shown in Figure 6 (note the reciprocal Area Replacement Ratio A/A_c is used). However, corrections should be applied to allow for the compressibility of the column aggregate and influence of the pressure gradient along the soil-column interface; features not catered for in earlier work (Priebe 1976).

The method of Baumann and Bauer (1974) is sometimes used in Europe, although it has a weaker theoretical basis than Priebe (1995) and is believed to give poorer settlement predictions for clayey soils (Slocombe, 2001). The approach of Goughnour and Bayuk (1979) is preferred in the United States, although the method is much more complex and the necessary parameters are not readily available from routine Ground Investigations.

With the continued development of more realistic constitutive soil models, designated geotechnical Finite Element (FE) software (and 2-D PLAXIS in particular) is being used to model stone column foundations (i.e. Debats *et al* 2003, Wehr and Herle 2006). The FE method has the particular advantage of allowing the ground improvement scheme to be modelled in unison with the slab or foundation it supports. It is also very useful for unusual situations for which no standard design method exists, such as the composite pile/ground improvement used to support raft foundations at Limehouse Basin in London. Here Continuous Flight Augered (CFA) Piles were constructed to within $\approx 3\text{m}$ of the ground surface. Stone columns were constructed from the top of the CFA piles to the ground surface to reinforce and even out variable made ground conditions.

4. SOFT OR MARGINAL GROUND CONDITIONS

The construction industry has been buoyant in Ireland over the past 5-10 years, and with the ever increasing pressure to develop marginal sites, there is considerable interest in the applicability of stone columns to cohesive and organic soils. The following checklist may be useful if contemplating a Stone Column ground improvement solution:

(i) Organic soils are characterised by high moisture content, plasticity index and compressibility and as a general rule, the higher the organic content, the more difficult it is to arrest settlement in these soils. Most organic silts and clays may be successfully treated. If present in a discrete layer less than $\approx 0.6\text{m}$ thick, a stone column may be formed in peat. However, for larger layer thicknesses or multiple thin bands, it is unlikely that the peat will provide adequate passive resistance to confine the column (Mitchell and Jardine 2002). It may be possible to install a dry plug of lean-mix concrete to bridge a compressible peat layer which is in excess of 0.6m in thickness, and this may be installed during the stone column construction process. Geogrids and geotextiles installed around the column’s perimeter have also been used to confine columns through weaker strata.

(ii) A lower limit to the undrained strength of $c_u=15\text{kPa}$ is suggested for treatment with stone columns, although there have been situations where softer soils have been successfully improved (Raju *et al*, 2004, and others). However it is not sufficient to consider the undisturbed strength of cohesive soil alone; the sensitivity of the soil to disturbance (S_t) is equally important:

$$S_t = \frac{c_{u \text{ undisturbed}}}{c_{u \text{ remoulded}}} \quad [4]$$

where $c_{u \text{ remoulded}}$ is the undrained strength of soil with its natural structure destroyed. Normally consolidated clays are more likely to be sensitive than overconsolidated clays, and while most clays have S_t values between 1 and 4, S_t may be as high as 150 in the case of the well publicized Scandanavian and Canadian quick clays. Vibrations from a depth vibrator can lead to a considerable loss of strength in very sensitive soils, which can impact upon the trafficability of

sites, adjacent structures and slope stability. Fortunately, Ireland has few soils in the very sensitive category.

(iii) Plasticity Index: The plasticity index (I_p) of a soil reflects the potential for volume change; swelling and shrinkage will not be controlled by adding stone columns. Although the UK National House Building Council (NHBC, 1988) suggests that stone columns should not be used when $I_p > 40\%$, high plasticity soils can still be improved by stone columns in certain circumstances.

(iv) Clay Fill: The self-weight settlement of recent clay fills (or mixed fills containing substantial clay) may be difficult to predict, especially if there has been little control in placement. While installation of stone columns through such fill may accelerate the settlement process, the magnitude of settlement will not be reduced. It is generally adopted practice, from extensive experience, that columns should not be used in clay fill which is less than 10 years in place.

Stone columns are of little benefit in loose fills which are susceptible to collapse settlement (such as may be present in back-filled quarry pits). Collapse settlement may arise from first-time inundation of water directly through the ground surface, from underneath the ground surface (such as a leaking pipe) or from a rising groundwater table. Stone columns may facilitate the passage of water unless suitable precautions are taken. Sudden settlement of the fill would lead to an instant loss of lateral support at the top of the column (Mitchell and Jardine, 2002).

5. RECENT STONE COLUMN RESEARCH

Recent innovative and high quality model tests carried out at the University of Glasgow (Muir Wood *et al*, 2000) and Queens University Belfast (McKelvey *et al*, 2004, Black *et al*, 2006) have improved our understanding of stone column behaviour. Details of the apparatus and procedures used may be found in the relevant references, but a summary of the main practical findings is provided here.

Muir Wood *et al*. (2000) conducted what is considered to be the most comprehensive laboratory model investigations of large groups of columns. The results suggest that the pre-

failure mechanisms and failure modes of column groups are different from those of an isolated column. It was reported that the area replacement ratio (A_c/A) influences the extent of column interaction and the load sharing between the columns and intervening ground. The research also claims that significant improvement to bearing capacity requires an area replacement ratio of $\approx 25\%$ or greater.

Perhaps the most fundamental aspect of this work was the postulation of a realistic group failure mechanism. The deformation patterns in the columns were observed upon excavating the ground around the loaded columns. Columns adjacent to the centre column exhibited the most distortion. This observation is in good agreement with the stress levels measured at this location. Most of the bulging, shearing and lateral deflection occurred within a 'conical' region directly beneath the foundation. The depth of this failure wedge increased as the area replacement ratio increased.

A four-part failure mechanism was proposed based upon these observations (Figure 7). A conical zone (Zone 1) exists immediately beneath the footing in which there is no column deformation as the clay itself and confinement of the rigid footing provide adequate passive resistance. In Zone 2 (which is immediately below Zone 1), deformations are plastic and column bulging, shearing and buckling of the columns were all observed. Zone 3 is referred to as the 'retaining unit' which effectively provides lateral support to the failure wedge underneath the footing. Zone 4 represents the 'extension' zone of the mechanism.

McKelvey *et al* (2004) used a transparent medium with 'clay-like' properties to allow visual monitoring of the columns throughout foundation loading. The main findings of this research relate to optimum column aspect ratio L/d (L = column length, d = column diameter).

Careful examination of the digital images taken during loading (Figure 8) showed that in the case of 'short' columns (i.e. $L/d = 6$), bulging took place over the entire length of the columns and they punched into the clay beneath their bases. The 'long' column ($L/d = 10$) deformed significantly in the upper region whereas the bottom portion remained undeformed. This suggests that there was little or no load transfer to the base in longer columns, with failure

arising from bulging or shear. McKelvey *et al* (2004) postulated a 'critical column length' of $L=6d$, which is in keeping with earlier work (Hughes and Withers, 1974, Muir Wood *et al* 2000).

Black *et al* (2006) developed a more sophisticated triaxial apparatus in which the boundary conditions imposed on a clay bed (reinforced with stone columns) can be regulated. Publication of this work is pending at the time of writing.

The Finite Element method has been used in some academic studies, most using the homogenisation technique (i.e. Lee and Pande, 1998) in which the constitutive models are developed from composite soil properties assigned to the entire reinforced zone. However, the FE Method's potential to address some of the key shortcomings in stone column design has not been harnessed. Collaborative research between NUI Galway's Civil Engineering Department and Keller Ground Engineering aims to use the FE Method in an applied sense to address issues such as:

(i) the behaviour of floating columns (or partial depth treatment); Priebe's (1995) formulation assumes that columns are terminated at a rigid layer, and

(ii) the extent to which stone columns arrest secondary or creep settlement, which is most prevalent in organic soils.

6. CASE HISTORY

Retirement Village, Ballinasloe, Co. Galway

At the time of writing, a new retirement village is under construction on the banks of the River Suck in Ballinasloe. The development comprises a two-storey nursing home and a four-storey apartment block, with site levels raised by 1-1.5m for flood protection. Ground conditions at the site are mixed but typically comprise of up to 1.5m of soft organic fill overlying medium dense and dense silty sandy gravel with occasional cobbles and boulders.

Rather than piling to depth to support the four-storey block, a ground improvement solution was implemented whereby the soft organic fill was removed and replaced with clean stone

(<75mm), with the same material used to raise site levels. Approximately 700 Vibro Stone Columns were installed from this elevated platform level to depths of up to 4m to densify the new fill and any underlying loose natural soils. Conventional strip foundations were then used, designed for an allowable bearing pressure of 175kN/m^2 in the four-storey block. Floor slabs were also treated.

Ironically, the two-storey nursing home has deeper deposits of soft organic clay and peat underneath, needing piled support. The piling system used is referred to as Vibro Concrete Columns (VCCs) and these may be constructed using the same rig as Vibro Stone Columns, with a change of poker. A further description of the VCC technique may be found in McCabe and McNeill (2006). It is not uncommon to use a suitable combination of Vibro Stone Columns and VCCs at one site.

7. CONCLUSIONS

The Irish construction industry has been slower than many of its European counterparts to recognise the technical and economic advantages that Vibro Stone Columns can provide. Ireland has an abundance of soft estuarine and alluvial soils and these may be improved sufficiently to allow standard foundations to be constructed at shallow depth, without the need to resort to deep piling.

Where ground conditions are suitable, stone column solutions have been shown to be more cost effective than trench fill in excess of 2m depth. In addition, stone columns can offer considerable contract programme savings over other ground improvement methods, such as preloading and vertical drains.

As with all geotechnical projects, a thorough site investigation with adequate information on soil strength and compressibility is essential.

8. ACKNOWLEDGEMENTS

The authors would like to thank Dr. V. Sivakumar, Queens University Belfast, for information used in preparation of the presentation associated with this written paper. Thanks also to Mr. David Whyte of Keller Ground Engineering and Mr. Eoghan Clifford of NUI Galway for proof reading the paper.

9. REFERENCES

- Baumann, V. and Bauer, G.E.A. (1974) The performance of foundations on various soils stabilized by the Vibro-Compaction Method, *Canadian Geotechnical Journal*, Vol. 11, No. 4, pp 509-530.
- Bell, A.L. (2004) The development and importance of construction technique in deep vibratory ground improvement, *Proc. Ground and Soil Improvement, Geotechnique Symposium*, edited by C.A. Raison, pp 103-111.
- Black, J.A., Sivakumar, V., Madhav, M.R. and McCabe, B.A. (2006) An improved experimental test set-up to study the behaviour of granular columns, *Geotechnical Testing Journal*, ASTM, Vol. 29, No. 3, pp 193-199.
- Debats, J.M., Guetif, Z. and Bouassida, M.(2003). Soft soil improvement due to vibro-compacted columns installation. *Proceedings of the International Workshop on Geotechnics of Soft-Soils-Theory and Practice*, pp 551-556.
- Etezad, M., Hanna, A.M. and Ayadat. T. (2006) Bearing capacity of groups of stone columns, *Proceedings of the 6th European Conference on Numerical Methods in Geotechnical Engineering*, Graz, pp. 781-786.
- Goughnour, R.R. and Bayuk, A.A. (1979) Analysis of stone column – soil matrix interaction under vertical load, *Proceedings of the International Conference on Soil Reinforcements*, Paris, pp 271-277.
- Hughes, J.M.O. and Withers, N.J. (1974) Reinforcing of soft cohesive soils with stone columns, *Ground Engineering*, Vol. 7, No. 3, pp 42-49.
- Lee, J.S. and Pande, G.N. (1998), Analysis of Stone Column Reinforced Foundations, *International Journal of Numerical and Analytical Methods in Geomechanics*, Vol. 22, pp 1001-1020.
- McCabe, B.A. and McNeill, J.A. (2006) Vibro Techniques for Ground Improvement in Ireland, *The Engineers Journal*, Vol. 60, Issue 3 (April), pp 181-182.
- McKelvey, D., Sivakumar, V., Bell, A. and Graham, J. (2004) Modelling vibrated stone columns in soft clay, *Proceedings of the Institute of Civil Engineers Geotechnical Engineering*, Vol. 157, Issue GE3, pp 137-149.
- Mitchell, J.M. and Jardine, F.M. (2002) A guide to ground treatment, *CIRIA Publication C572*.
- Muir Wood, D., Hu, W. and Nash, D.F.T. (2000) Group effects in stone column foundations – model tests, *Geotechnique*, Vol. 50, No. 6, pp 689-698.
- NHBC (1988) National House Building Council Standards, Vibratory ground improvement techniques (Chapter 4.6).
- Priebe, H.J. (1976) Evaluation of the settlement reduction of a foundation improved by Vibro-Replacement, *Bautechnik*, No. 5, pp 160-162 (in German)
- Priebe, H.J. (1995) The design of Vibro Replacement, *Ground Engineering* (Dec), pp 31-37.
- Raju, V.R., Hari Krishna, R. and Wegner, R. (2004) Ground improvement using Vibro Replacement in Asia 1994 to 2004 – a 10 year review, *Proceedings of 5th Int. Conf. on Ground Improvement Techniques*, Kuala Lumpur, Malaysia.
- Slocombe, B.C. (2001) Deep compaction of problematic soils, *Problematic Soils*, Thomas Telford (London), pp 163-181.
- Slocombe, B.C., Bell, A.L. and Baez, J.I. (2000) The densification of granular soil using Vibro methods, *Geotechnique*, Vol. L, No. 6, pp 715-726.
- Sondermann, W. and Wehr, W. (2004) Deep Vibro techniques, *Ground Improvement*, 2nd Edition, edited by M.P. Moseley and K. Kirsch, pp 57-92, Spon Press.
- Wehr, J. and Herle, I. (2006) Exercise on calculation of stone columns - Priebe method and FEM, *Proceedings of the 6th European Conference on Numerical Methods in Geotechnical Engineering*, Graz, pp. 773-776.
- Wroth, C.P. (1984) The interpretation of in situ soil tests, *Geotechnique*, Vol. 34, No. 4, pp 449-489.

Soil type	Bearing pressure (kPa)	Settlement (mm)
Made Ground: mixed cohesive and granular	100-165	5-25
Made Ground: Granular fill, ash, brick, rubble etc.	100-215	5-20
Natural sands or sands and gravels	165-500	5-25
Soft Alluvial Clays	50-100	15-75

Table 1: Bearing pressures and settlements ranges after vibratory stabilisation for normal foundations (after Slocombe, 2001)

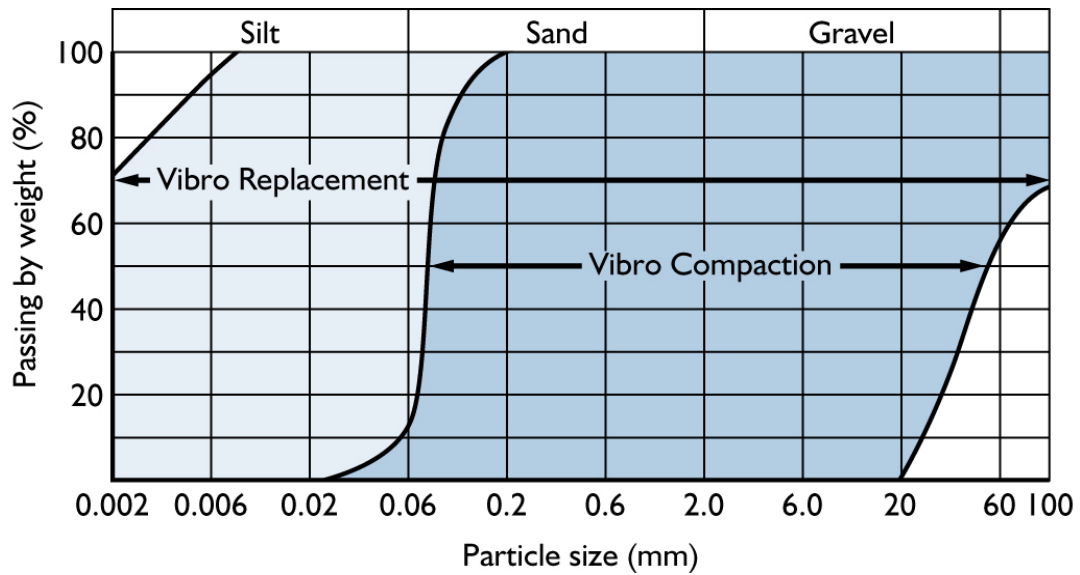

Figure 1: Particle size distribution illustrating applicability of Vibro-Compaction and Vibro-Replacement

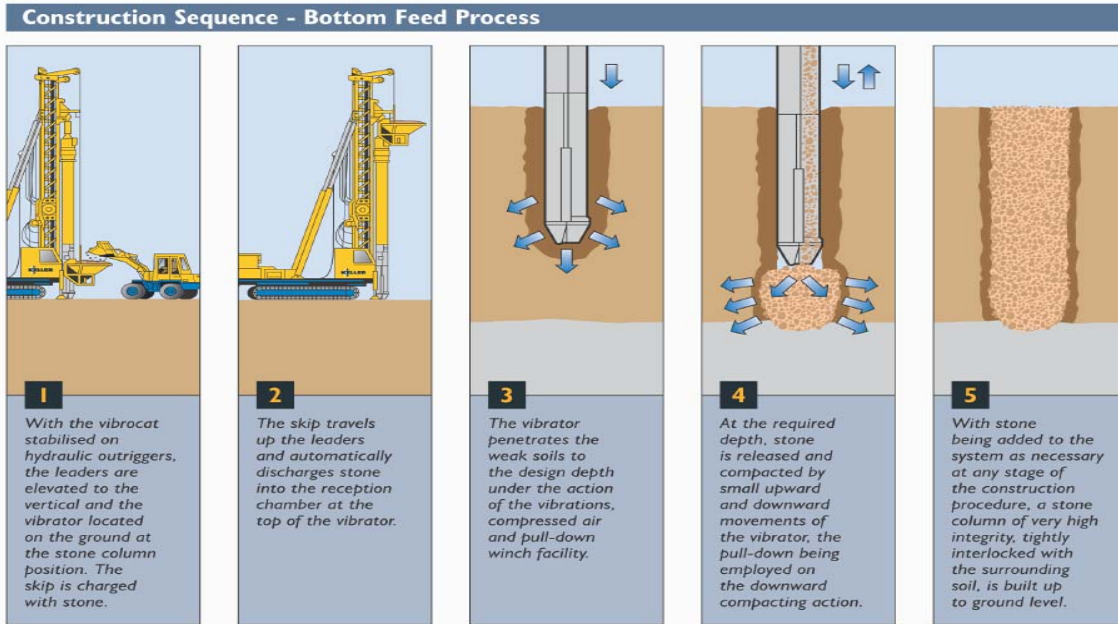

Figure 2: Bottom Feed method of stone column construction

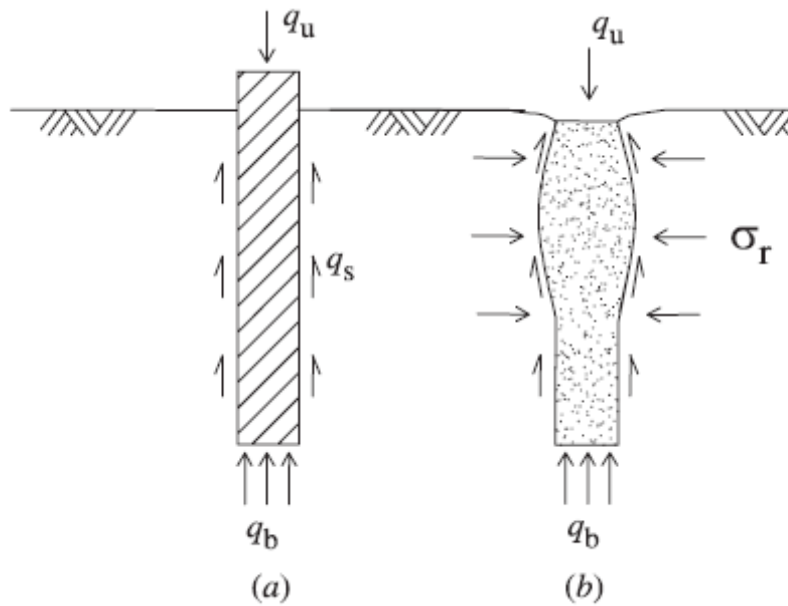

Figure 3: Mechanisms of load transfer for (a) a rigid pile and (b) a stone column (after Hughes and Withers 1974)



Figure 4: Model tests on stone column showing characteristic bulging behaviour (Plymouth University)

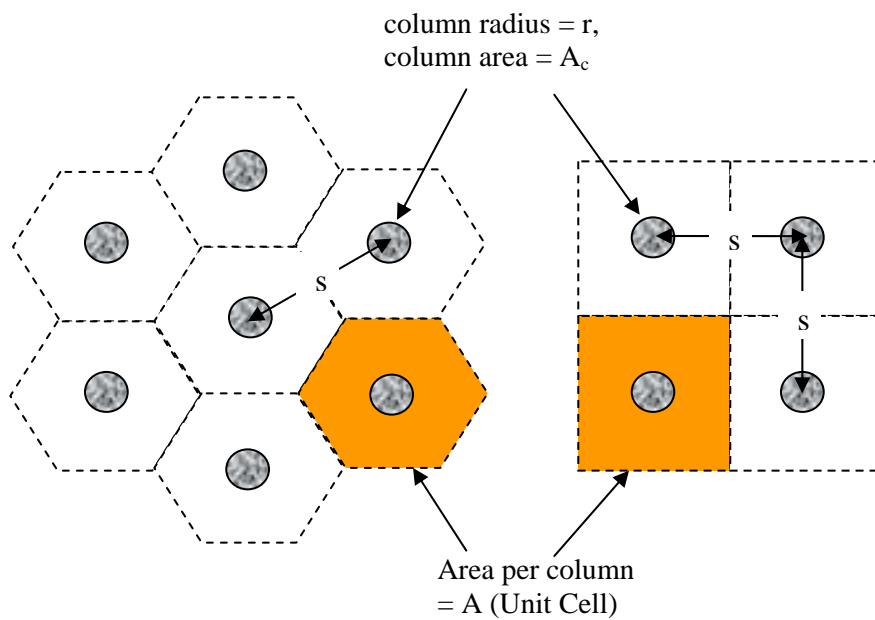

Figure 5: Typical column arrangements, triangular grid (left) and square grid (right)

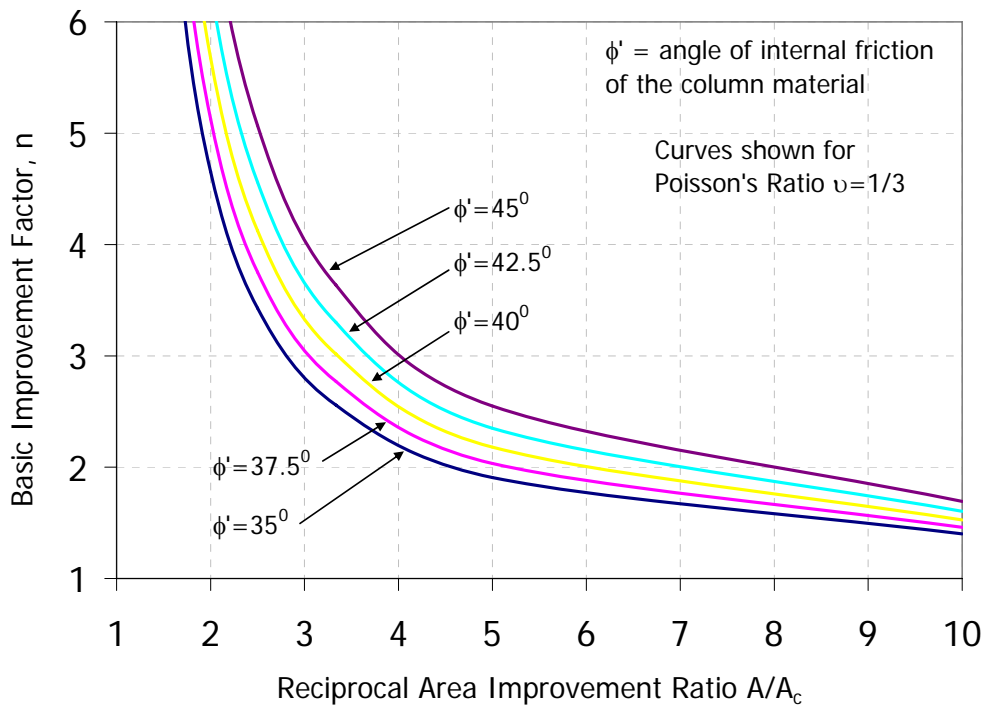

Figure 6: Priebe's basic improvement factor (reproduced from Priebe, 1995)

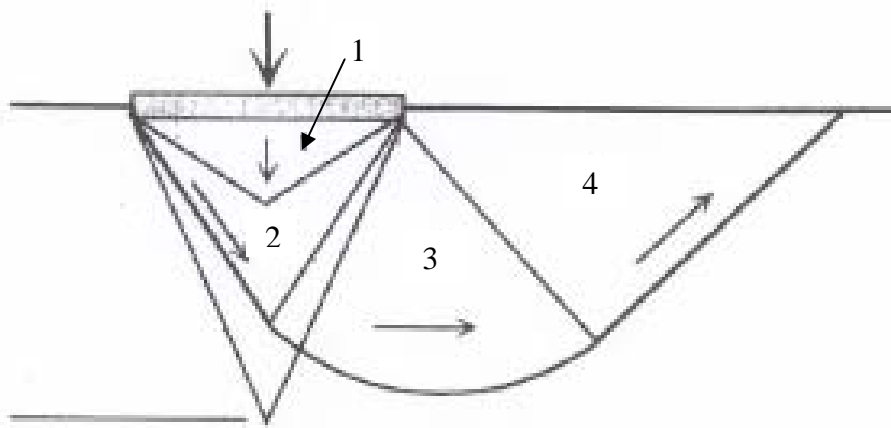

Figure 7: Four-zone failure mechanism proposed by Muir Wood *et al* (2000) for stone column groups

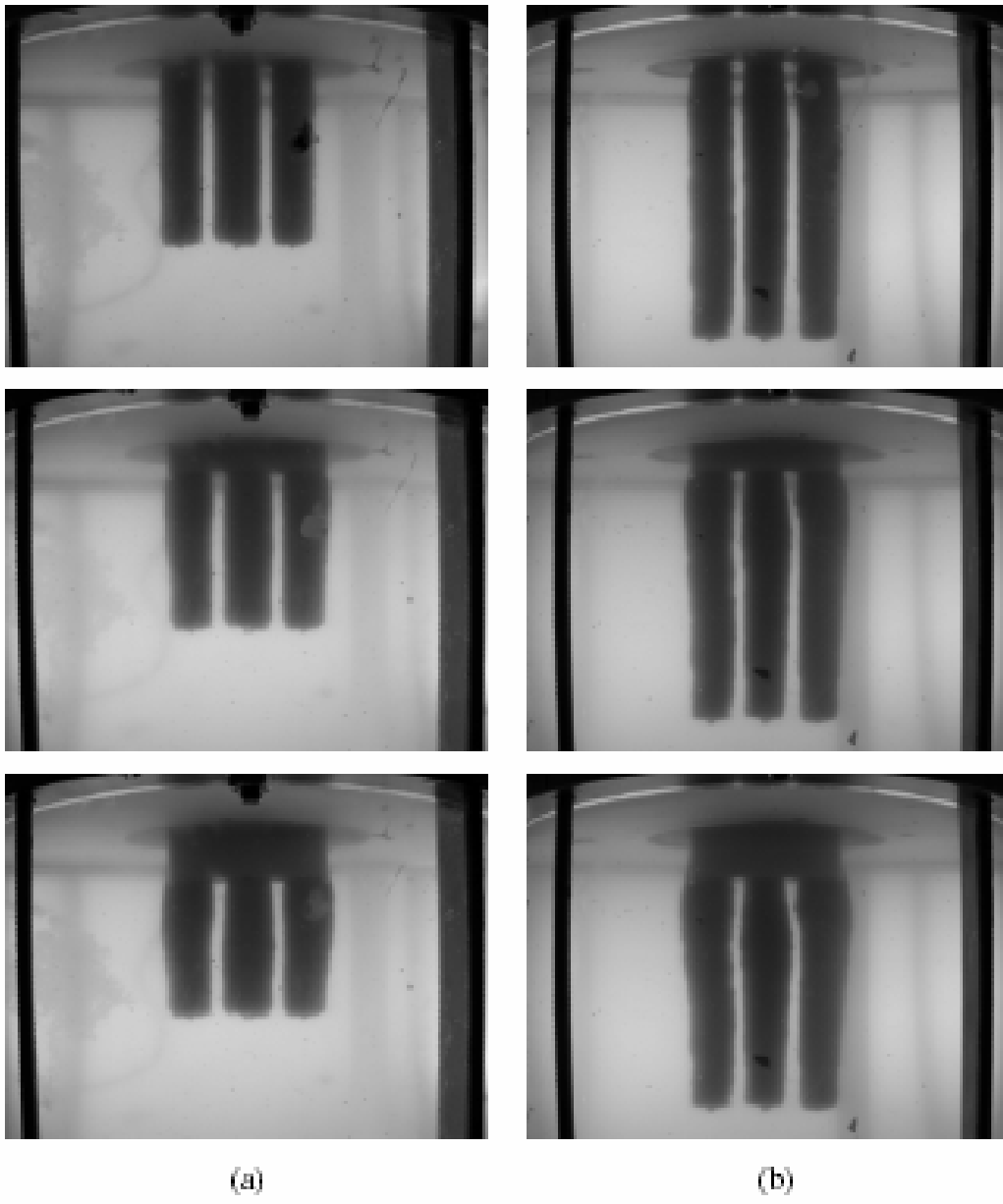

Figure 8: Photographs of sand columns beneath circular footing, before, during and after loading (a) $L/d=6$, (b) $L/d=10$, (McKelvey *et al*, 2004)